



# INSTALLATION AND SERVICING

## VISCOUNT GTS 14 - 25

When replacing any part on this appliance, use only spare parts that you can be assured conform to the safety and performance specification that we require. Do not use reconditioned or copy parts that have not been clearly authorised by Ideal.

For the very latest copy of literature for specification and maintenance practices visit our website [www.idealcommercialboilers.com](http://www.idealcommercialboilers.com) where you can download the relevant information in PDF format.



## Table 1 Technical Specifications

### Boiler:

Maximum operating pressure : 6 bar  
 Maximum operating temperature : 100°C

Boiler thermostat setting 30 - 90°C  
 Safety thermostat setting 110°C

Boiler Size (no. of sections)		14	15	16	17	18	19	20	21	22	23	24	25
Maximum heat output	kW	812	870	928	986	1044	1102	1160	1218	1276	1334	1400	1450
	Btu/h x 10 <sup>3</sup>	2770	2968	3166	3364	3562	3760	3958	4156	4354	4552	4777	4947
Minimum heat output	kw	754	812	870	928	986	1044	1102	1160	1218	1276	1334	1400
	Btu/h x 10 <sup>3</sup>	2573	2770	2968	3166	3364	3562	3760	3958	4156	4354	4552	4770
Boiler water content	l	655	693	731	769	807	845	905	943	981	1019	1057	1095
	gal	144	152	161	169	177	186	199	207	216	224	232	241
Hydraulic resistance at 15K	mbar	30	34.7	14	15	17.5	19	21.5	23.7	26	28.3	32	35
	in.w.g.	12	13.8	5.6	6	7	7.6	8.6	9.5	10.4	11.3	12.8	14
Combustion chamber Resistance (at zero draught)	mbar	2.3	2.4	2.5	2.6	2.7	2.85	3	3.1	3.2	3.3	3.4	3.5
	in.w.g.	0.92	0.96	1	1.04	1.08	1.14	1.2	1.24	1.28	1.32	1.36	1.4
Boiler Dry weight less Burner unit	kg	3171	3364	3561	3756	3955	4124	4343	4538	4734	4930	5107	5297
	lb	6993	7416	7850	8280	8719	9092	9575	10,005	10,437	10,869	11,259	11678
Maximum oil rate	l/h	82.73	88.64	94.55	100.5	106.4	112.3	118.2	124	130	135.9	142.6	147.7
	gal/h	18.2	19.5	20.8	22.1	23.4	24.7	26	27.3	28.6	29.9	31.4	32.5
Maximum flue gas volume (oil)* * 13% CO <sub>2</sub> at 210C	m <sup>3</sup> /sec	0.51	0.55	0.59	0.62	0.66	0.70	0.73	0.77	0.81	0.84	0.89	0.92
	ft <sup>3</sup> /min	1081	1166	1250	1314	1399	1483	1547	1632	1717	1780	1883	1950
Maximum gas rate	m <sup>3</sup> /h	84.4	90.4	96.4	102.4	108.5	114.5	120.5	126.5	132.5	138.6	145.5	150.6
	ft <sup>3</sup> /h	2980	3192	3403	3616	3831	4043	4255	4466	4678	4894	5138	5317
Maximum flue gas volume (gas)* * 9.5% CO <sub>2</sub> at 210C	m <sup>3</sup> /sec	0.57	0.61	0.65	0.69	0.73	0.77	0.81	0.85	0.89	0.94	0.98	1.02
	ft <sup>3</sup> /min	1208	1293	1377	1462	1547	1632	1717	1801	1886	1992	2084	2162

### Note.

*Fuel rates and flue gas data relate to maximum output ratings.*

*Gas firing data relates to the use of NATURAL GAS ONLY.*

*Details for the use of LPG are available on request from Ideal Boilers.*

The gas rate at calorific values differing from the standard quoted above may be calculated by direct proportion. CALORIFIC VALUE: 38.5 MJ/m<sup>3</sup> (1,035 Btu/ft<sup>3</sup>).

### HEALTH & SAFETY DOCUMENT NO. 635

**The electricity at work regulations, 1989.** The manufacturer's notes must NOT be taken, in any way, as overriding statutory obligations.

**IMPORTANT.** These appliances are CE certified for safety and performance. It is, therefore, important that no external control devices, e.g. flue dampers, economisers etc., are directly connected to these appliances unless covered by these Installation and Servicing Instructions or as otherwise recommended by **Ideal Boilers** in writing. If in doubt please enquire.

Any direct connection of a control device not approved by **Ideal Boilers** could invalidate the certification and the normal appliance warranty. It could also infringe the Gas Safety Regulations and the above regulations.

# CONTENTS

Boiler Dimensions.....	6
Commissioning and Testing.....	46
Electrical Supply.....	5
Flue Installation.....	5
Fluing.....	10
Gas Safety Regulations.....	4
Gas Supply.....	4
Initial Lighting.....	46
Introduction.....	3
Installation.....	7
Option Kits.....	3
Performance Data.....	2
Servicing.....	47
Ventilation.....	8
Water Circulation.....	5
Water Connections.....	8
Water System Requirements.....	9
Water Treatment.....	5
Wiring Diagram.....	44

## Viscount GTS

Oil, Gas or Dual Fuel Fired Boilers

Destination Countries: GB, IE

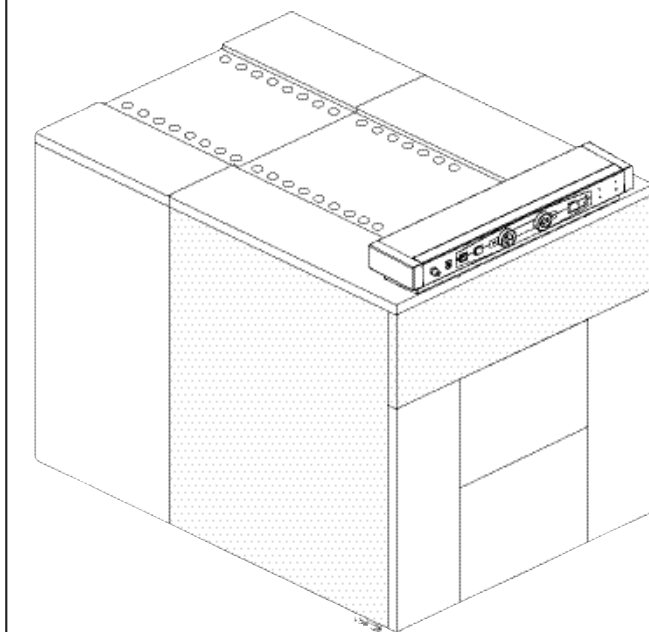

### GENERAL

The boilers of the Viscount GTS range are pressurised hot water boilers designed for connecting to a flue pipe which require a separate automatic fuel-oil or gas burner. The heat output of Viscount GTS boilers is between 754 and 1500 kW.

- Viscount GTS**

Boiler with standard control panel designed to be connected to the electrical cabinet.

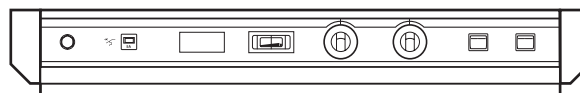

VIS5054

**Option Kits:**

Flue Gas Thermometer Pack ID28

**CAUTION.** To avoid the possibility of injury during the installation, servicing or cleaning of this appliance, care should be taken when handling edges of sheet steel components.

# GENERAL

## SAFETY

### Current Gas Safety (Installation and Use) Regulations or rules in force.

It is law that all gas appliances are installed and serviced by a Gas Safe registered installer in accordance with the regulations below. Failure to install appliances correctly could lead to prosecution. It is in your own interest, and that of safety, to ensure the law is complied with.

The following must be conformed with:

Current Building Regulations and Clean Air Act

Water Authority Regulations

Local Authority Regulations and Regional Bylaws

Gas Safety Regulations

Any special regional requirements of local Electricity and Gas undertaking.

Fire Service and Insurance Company requirements.

In the interests of safety, a competent installer should be employed to effect the installation of the appliance. Manufacturer's notes must NOT, in any way, be taken as overriding statutory obligations.

The installation of the boiler MUST also be in accordance with the latest I.E.E. (BS7671) Wiring Regulations, local buildings regulations, bye-laws of the local water authority, the building regulations and the Building Standards (Scotland) and any relevant requirements of the local authority.

Detailed recommendations are contained in the following Codes of Practice:

<b>BS 799 Pt4 &amp; 7</b>	Oil burning equipment.
<b>BS 799 Pt5</b>	Oil storage tanks.
<b>BS 5410 Pt1</b>	Installation for space heating and hot water supply.
<b>BS 5854</b>	Flues and flue structures in buildings.
<b>BS 5885 Pt1</b>	Gas burners - with inputs 60kW and above.
<b>BS 6644</b>	Installation of gas fired hot water boilers of rated input between 70kW and 1.8MW (net) (2nd and 3rd family gases).
<b>BS 6880</b>	Low temperature hot water heating systems of output greater than 45kW.
Part 1	Fundamental and design considerations
Part 2	Selection of equipment.
Part 3	Installation, commissioning and maintenance.
<b>BS 6891</b>	Installation of low pressure gas pipework of up to 28mm (R1) in domestic premises (2nd family gas).
<b>EN 303.1</b>	Heating boilers with forced draught burners. General requirements.
<b>EN 303.2</b>	Heating boilers with forced draught burners with

atomising oil burners.

<b>EN 304</b>	Test code for heating boilers for atomizing oil burners.
<b>73/23 EEC</b>	Low voltage directive. (Relevant standard is EN60335.1)
<b>89/336 EEC</b>	Electromagnetic Compatibility Directive. (Relevant standards are EN50081.1, EN50082.1 and EN55014.)
<b>90/396 EEC</b>	Gas Appliance Directive. (Relevant standards are EN303.1, EN303.2 and EN304.)
<b>IGE/UP/1</b>	Soundness testing and purging of industrial and commercial gas installation.
<b>IGE/UP/2</b>	Gas installation pipework, boosters and compressors on industrial and commercial premises.
<b>IGE/UP/10</b>	Installation of gas appliances in industrial and commercial premises.

## SAFE HANDLING OF SUBSTANCES

Care should be taken when handling the boiler insulation panels, which can cause irritation to the skin. No asbestos, mercury or CFCs are included in any part of the boiler or its manufacture.

## GAS SUPPLY

The local gas supplier should be consulted, at the installation planning stage, in order to establish the availability of an adequate supply of gas. An existing service pipe must NOT be used without prior consultation with the local gas supplier.

A gas meter can only be connected by the local gas supplier or by a registered Gas Safe engineer.

An existing meter should be checked, preferably by the gas supplier, to ensure that the meter is adequate to deal with the rate of gas supply required. A minimum working gas pressure of 17.5mbar MUST be available at the boiler inlet for Natural gas and 37mbar for Propane.

Do not use pipes of smaller size than the burner inlet gas connection.

The complete installation MUST be tested for gas soundness and purged in accordance with the appropriate standards listed on page 4.

### Gas Boosters

A gas booster is required if the gas pressure available at the burner is lower than that required by the burner manufacturer to attain the flow rate for maximum burner input rating.

Location of the booster requires careful consideration but should preferably be closer to the burner rather than the gas meter. Ventilation should also be considered to ensure ambient temperatures do not exceed designed recommendations. Further guidance is provided in IGE/UP/2 as listed above.

## FLUE INSTALLATION

### IMPORTANT

It is the responsibility of the installer to ensure, in practice, that

**Assembly and Installation Instructions for Viscount GTS heating boilers should be read in conjunction with the general technical data tables enclosed and any other technical publication supplied with the burner.**

**NOTE TO THE INSTALLER: LEAVE THESE INSTRUCTIONS ADJACENT TO THE BOILER**

# GENERAL

products of combustion discharging from the terminal cannot re-enter the building or any other adjacent building through ventilators, windows, doors, other sources of natural air infiltration, or forced ventilation / air conditioning.

If this should occur the appliance MUST be turned OFF, labelled as 'unsafe' and corrective action taken.

The flue must be installed in accordance with the appropriate standards listed on page 4.

## WATER CIRCULATION SYSTEM

The system pump MUST be connected to the boiler.

The boiler must NOT be used for direct hot water supply. The hot water storage cylinder MUST be of the indirect type.

The appliances are NOT suitable for gravity central heating nor are they suitable for the provision of gravity domestic hot water.

The hot water cylinder and ancillary pipework, not forming part of the useful heating surface, should be lagged to prevent heat loss and any possible freezing - particularly where pipes run through roof spaces and ventilated underfloor spaces.

The boiler must be vented.

Draining taps MUST be located in accessible positions, which permit the draining of the whole system - including the boiler and hot water storage vessel. They should be at least 1/2" BSP nominal size and be in accordance with BS. 2879.

The central heating system should be in accordance with the relevant standards listed on page 4.

Due to the design of the boiler the heat stored within the castings at the point of shutdown of the burner must be dissipated in order to avoid overheating. In order to allow pump operation after burner shutdown the boiler control system should incorporate a pump overrun device.

## WATER TREATMENT FOR HOT WATER AND HEATING BOILERS

There is a basic need to treat the water contained in all heating and indirect water systems, particularly open vented systems. It is assumed, incorrectly, that because boilers are operating in conjunction with what is apparently a closed circuit an open vented system will not, under normal circumstances, allow damage or loss of efficiency due to hardness salts and corrosion once the initial charge of water has been heated up a few times.

1mm of lime reduces the heat transfer from metal to water by 10%.

In practice the deposition of these salts is liable to cause noises from the boiler body or even premature boiler failure. Corrosion and the formation of black iron oxide sludge will ultimately result in premature radiator failure.

Open vented systems are not completely sealed from the atmosphere if proper venting and expansion of system water is to be achieved. The same tank is used to fill the system with water and it is through the cold feed pipe that system water expands into the tank when the boiler passes heat into the system.

Conversely, when the system cools, water previously expelled is drawn back from the tank into the system together with a quantity of dissolved oxygen.

Even if leakage from the heating and hot water system is eliminated there will be evaporation losses from the surface of the tank which, depending upon ambient temperature, may be high enough to evaporate a large portion of the system water capacity over a full heating season.

There will always be corrosion within a heating or hot water system to a greater or lesser degree, irrespective of water characteristics, unless the initial fill water from the mains is treated. Even the water in closed systems will promote corrosion unless treated. For the reason stated, **Ideal Boilers** strongly recommend that when necessary the systems is thoroughly cleaned, prior to the use of stable inhibitor, which does not require continual topping up to combat the effects of hardness salts and corrosion on the heat exchangers of the boiler and associated systems.

**Ideal Boilers** advise contact directly with specialists on water treatment such as:

GE Betz Ltd, Sentinel Division, Foundry Lane,  
Widnes, Cheshire, WA8 8UD,  
Tel: +44 (0) 151 424 5351

Fernox Manufacturing Co. Ltd., Cookson Electronics,  
Forsyth Road, Sheerwater, Woking, Surrey, GU21 5RZ  
Tel: +44 (0) 799 521 133

## ELECTRICAL SUPPLY

**WARNING** This appliance must be earthed.

The control system requires a 230V - 50Hz mains supply.

Wiring external to the appliance MUST be in accordance with the current I.E.E. (BS7671) Wiring Regulations and any local regulations which apply.

### Burner and Pump

These may be 1ph or 3ph. Refer to manufacturer's instructions.

The point of connection to the mains should be readily accessible and adjacent to the boiler.

## BURNER MOUNTING

When mounting the burner to the boiler front door, check for soundness around the burner flange and its gasket. If there is space between the burner blast tube and door insulation after mounting the burner a suitable insulation material should be used to pack this space.

1 MAIN DIMENSIONS

Viscount GTS

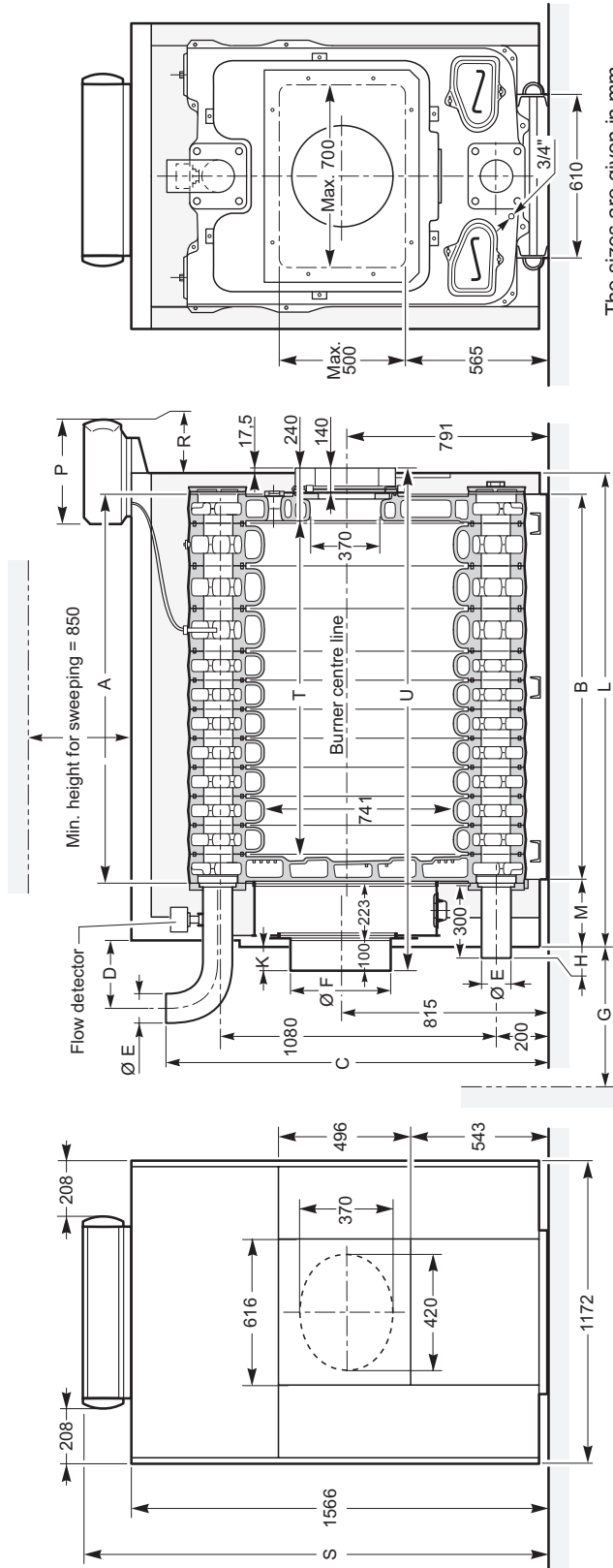

The sizes are given in mm  
vis9130

GTS Boiler	14	15	16	17	18	19	20	21	22	23	24	25
A (mm)	1674	1785	1896	2007	2118	2229	2380	2491	2602	2713	2824	2935
B (mm)	1744	1744	1966	1966	2188	2188	2450	2450	2672	2672	2894	2894
C (mm)	1488	1488	1488	1488	1504	1504	1504	1504	1504	1504	1504	1504
D (mm)	217	188	189	210	236	257	208	209	230	231	252	253
ø E (weld)	139.7	139.7	139.7	139.7	159	159	159	159	159	159	159	159
ø F (mm)	400	400	400	400	400	400	400	*	*	*	*	*
G (mm)	-	150	150	370	370	370	650	650	650	980	980	980
H (mm)	-2	-31	-30	-9	-8	13	-36	-35	-14	-13	8	9
K** (mm)	10	-19	-18	3	4	25	-24	-23	-2	-1	20	21
L (mm)	2105	2245	2355	2445	2555	2645	2845	2955	3045	3155	3245	3355
M (mm)	259	324	269	321	265	299	269	324	269	324	249	303
P (mm)	130	130	130	130	130	130	130	130	130	130	130	130
R (mm)	20	20	20	20	20	20	20	20	20	20	20	20
S (mm)	1670	1670	1670	1670	1670	1670	1670	1670	1670	1670	1670	1670
T (mm)	1483	1594	1705	1816	1927	2038	2189	2300	2411	2522	2633	2744
U (mm)	2132.5	2243.5	2354.5	2465.5	2576.5	2687.5	2838.5	2949.5	3060.5	3171.5	3282.5	3393.5

\* Plain plate, requires cutting. Maximum cut-out 500 x 700mm  
G = Length required for clearing the water distributing tube  
\*\* Dimension representing the end of the 100 mm long chimney connection  
Note: with models 21, 22, 23, 24 and 25, a plain plate which must be cut out is supplied without the 100 mm chimney connection.

# INSTALLATION

## 2 INSTALLING THE BOILER

### Boiler Location

For the assembly and because of their design, GTS boilers require no special base or stand and their closed furnace system means that the floor need not have refractory properties. All you have to ensure is that the floor can support the weight of the boiler when it is fitted for operation. If the boiler location is not determined precisely, leave enough space around the boiler to facilitate monitoring and maintenance operations.

If the boiler is mounted on a plinth then the dimensions must

exceed the plan area of the boiler by at least 75mm on each side. The boiler must not be fitted outside.

## 3 Ventilation

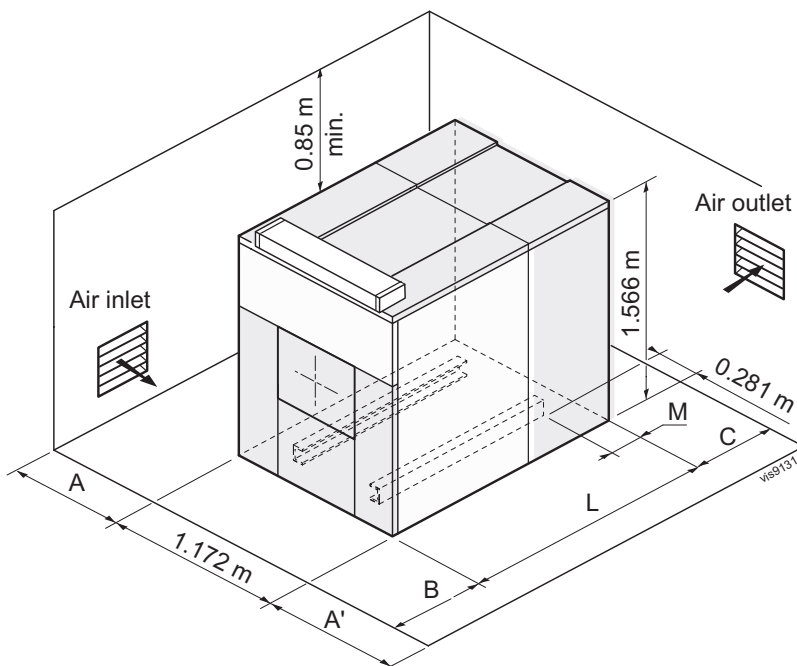
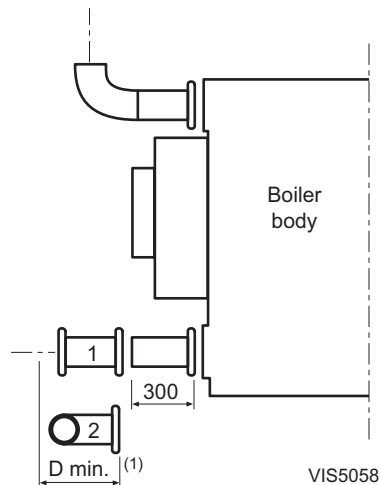

1. Straight connection (not supplied)
  2. Angled connection (not supplied)
- (1) In order to facilitate subsequent work on the boiler (replacing the water distributing tube etc.) use a flanged connection from the boiler to the system, making sure you comply with minimum clearance dimension **D**.

If **A = 1.2 m** (door opening side), **A' = 0.5 m**

If **A = 0.5 m, A' = 1.2 m** (door opening side) : adapt the dimensions on the basis of the dimensions of the burner when the door is open.

**B = 1.5 m** : adapt the dimensions on the basis of the dimensions of the burner.

GTS	14	15	16	17	18	19	20	21	22	23	24	25
L	2105	2245	2355	2445	2555	2645	2845	2955	3045	3155	3245	3355
M	259	324	269	321	265	299	269	324	269	324	249	303
Cmin.	300	436	436	656	656	656	936	936	936	1266	1266	1266
Dmin.	-	136	136	356	356	356	636	636	636	966	966	966

# INSTALLATION

The ventilation shall comply with applicable regulations, particularly codes of practice.

Detailed recommendations for air supply are quoted in B.S. 6644.

**Please note :** remember that boilers installed in or close to rooms in which the atmosphere is polluted with chlorine or fluorine compounds may be subject to high corrosion.

For example : hairdressing salons, industrial premises (solvents), cooling equipment, etc.

Boiler installed in such locations shall not be covered by the warranty.

## 4 HYDRAULIC CONNECTIONS

### Dimensional Information Required

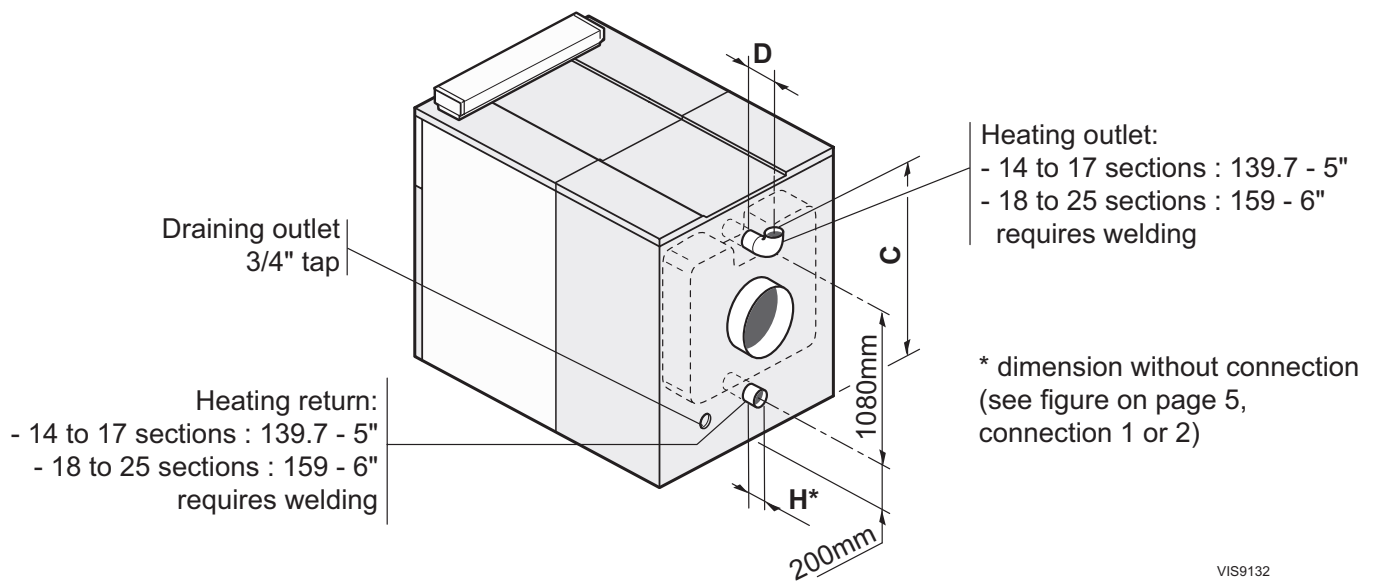

VIS9132

GTS	14	15	16	17	18	19	20	21	22	23	24	25
C (mm)	1488	1488	1488	1488	1504	1504	1504	1504	1504	1504	1504	1504
D (mm)	217	188	189	210	236	257	208	209	230	231	252	253
H (mm)	-2	-31	-30	-9	-8	13	-36	-35	-14	-13	8	9



## 5 FILLING THE SYSTEM

Filling shall be performed with a low flow rate from a low point in the

boiler room in order to ensure that all the air in the boiler is bled from the high point of the system.

Always stop the pump before filling.

### VERY IMPORTANT :

#### Instructions for starting up the boiler for the first time after the system is fully or partly drained :

If all the air is not bled naturally to an expansion vessel which opens out onto the air, the system must include manual bleeder valves, in addition to automatic bleeder valves with the capability to bleed the system by themselves when it is operating. The manual bleeder valves are used to bleed all the high points of the system and to make sure that the filled system is free of air before the burner is turned on.

#### General

Recommendations relating to the water system are contained in BS. 5449 Pt. 2 and BS. 6880.

## 6 SLUDGE REMOVAL

A tapped  $\varnothing$  2" hole with a plug has been provided on the bottom of the front of the boiler. Fit a quarter-turn valve on the opening to remove the sludge.

Sludge removal leads to the draining of large quantities of water, so remember to refill the system after the operation.

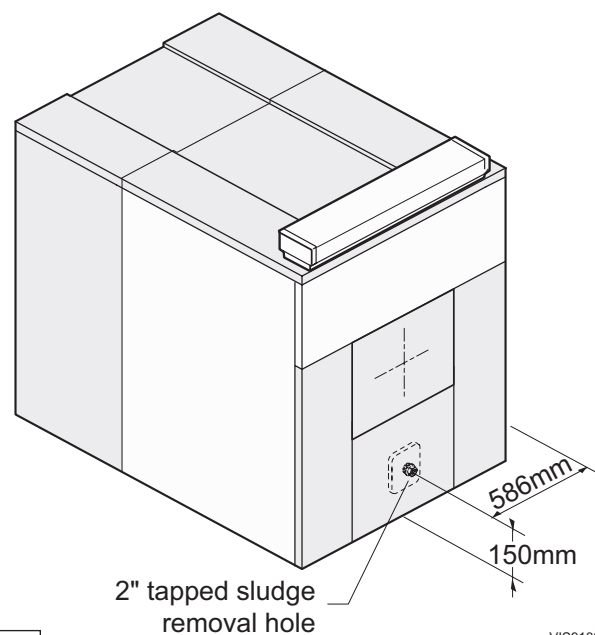

VIS9133



### NOTE:

Never replace a boiler in an existing system without carefully rinsing the system first. Install a sludge trap on the return pipe, very close to the boiler.

# INSTALLATION

## 7 CHIMNEY CONNECTION

The high-performance features of modern boilers and their use in specific conditions as a result of the advance in burner technology (e.g. first-stage or low modulation range operation) lead to very low flue gas temperatures (less than 160°C).

This requires :

- Flue insulation.
- the use of flue pipes designed to enable the flow of condensates which may result from such operating modes, in order to prevent damage to the chimney.
- the installation of a draining tee at the foot of the chimney.

The use of a draught moderator is recommended as well.

### Flue Size

Refer to applicable regulations while determining the size and height of the flue. Please note that GTS boilers have pressurised and tight furnaces and that the pressure at the outlet must not exceed 0 mbar, unless special sealing precautions have been taken, for instance in order to connect a static condenser.

Detailed recommendations relating to the design of flues for GAS fired appliances are quoted in BS. 6644 and IGE Publication UP/10, whilst BS. 5410 Pt. 3 similarly applies to OIL fired boilers.

### Connecting to the flue

The connection shall be removable, and offer minimum load losses, i.e. it must be as short as possible with no sudden change

in section.

Its diameter shall always be at least equal to that of the boiler outlet, i.e. :

- $\varnothing$  400 mm for 14-20 sections
- Boilers with 21-25 sections are supplied with a plain plate. The maximum cutout dimensions are 500 x 700 mm.

Fit a measuring point ( $\varnothing$  10 mm hole) on the flue, in order to adjust the burner (combustion check).

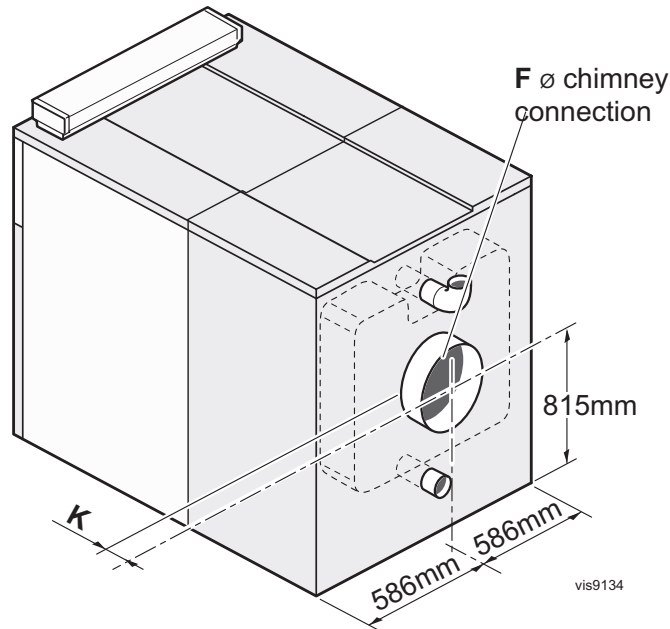

GTS	14	15	16	17	18	19	20	21	22	23	24	25
Ø F (mm)	400	400	400	400	400	400	400	plain plate	plain plate	plain plate	plain plate	Plain plate
K (mm)	10	-19	-18	3	4	25	-24	-23*	-2*	-1*	20*	21*

\* Dimension representing the end of the 100 mm long chimney connection.

**Note:** with models 21, 22, 23, 24 and 25 a plain plate which requires cutting out is supplied without the 100 mm long chimney connection.

# INSTALLATION

## 8 ASSEMBLY OF VISCOUNT GTS BOILERS



### IMPORTANT

Important : Assemble the boiler in the order given by the numbers of each figure, in compliance with all the instructions.

### Packaging :

Before starting to assemble the boiler, refer to the table below to check if you have received all the packages required.

### Boiler Body and Accessories

- Boilers supplied with an assembled body: start assembly from figure 13

GTS boiler	Number of sections	14	15	16	17	18	19	20	21	22	23	24	25
Assembled boiler body (contents depend upon model)		1	1	1	1	1	1	1	1	1	1	1	1
Cleaning tool kit (contents depend upon model)		1	1	1	1	1	1	1	1	1	1	1	1

- Boilers supplied with an unassembled body:

GTS boiler	Number of sections	14	15	16	17	18	19	20	21	22	23	24	25
Frame (dimensions depend upon model)		1	1	1	1	1	1	1	1	1	1	1	1
Rear section		1	1	1	1	1	1	1	1	1	1	1	1
Normal intermediate section		9	10	11	12	13	14	14	15	16	17	18	19
Special intermediate section		3	3	3	3	3	3	4	4	4	4	4	4
Front section		1	1	1	1	1	1	1	1	1	1	1	1
Set of assembly rods + cleaning tools (contents depend upon model)		1	1	1	1	1	1	1	1	1	1	1	1
Standard accessory kit (contents depend upon model)	1 package	FA 49	FA 50*	FA 51*	FA 52*	FA 53*	FA 54*	FA 55	FA 56	FA 57	FA 58	FA 59	FA 60
Additional accessory kit (contents depend upon model)	1 package	FA 68**	FA 69	FA 70	FA 71	FA 72	FA 73	FA 74	FA 75	FA 76	FA 77	FA 78	FA 79
Plain furnace plate		1	1	1	1	1	1	1	1	1	1	1	1
Flue gas connection plate with opening $\varnothing$ 400		1	1	1	1	1	1	1					
Plain flue gas connection plate									1	1	1	1	1
Flue gas box		1	1	1	1	1	1	1	1	1	1	1	1
Distributing tube fitting *								1	1	1	1	1	1
Flow switch and technical instructions		1	1	1	1	1	1	1	1	1	1	1	1

\* The distributing tube fitting for GTS boilers with 15 -19 sections is included in the accessory package.

\*\* The diaphragm fitting for GTS boilers with 14 sections is included in the additional accessory kit package.

- Baffle Plates

GTS boiler	Number of sections	14	15	16	17	18	19	20	21	22	23	24	25
Baffle Plates	Package CM 22		1	1	1	1	1						
	Package CM 23	1	1	1	1	1	1	2	2	2	2	2	2

- Casing Fittings

GTS boiler	Number of sections	14	15	16	17	18	19	20	21	22	23	24	25
Casing Fittings	Package IG 84	1	1	1	1								
	Package IG 85					1	1	1	1	1	1	1	1
	Package MR 3	1											
	Package MR 4		1		1		1	1		1		1	
	Package MR 5			1		1			1		1		1
	Package FA 10				2	2	1			2	2	1	1
	Package FA 11	2	2	2	1	1	2	3	3	2	2	3	3

# INSTALLATION

## 9 ASSEMBLY OF VISCOUNT GTS BOILERS - contd

- Variable Casing Parts

GTS boiler	Number of sections	14	15	16	17	18	19	20	21	22	23	24	25
Package FA 16						1	1	1	1	1	1	1	1
Package FA 17						1							
Package FA 18							1						
Package FA 19								1					
Package FA 20									1				
Package FA 21										1			
Package FA 22											1		
Package FA 23												1	
Package FA 24	1												1
Package FA 25			1										
Package FA 26				1									
Package FA 27					1								

- Body Insulating Material

GTS boiler	Number of sections	14	15	16	17	18	19	20	21	22	23	24	25
Body insulating material	Package FA 34	1											
	Package FA 35		1										
	Package FA 36			1	1								
	Package FA 37					1	1						
	Package FA 38							1					
	Package FA 39								1	1			
	Package FA 40										1	1	
	Package FA 41												1

- Control Panel

GTS boiler	Number of sections	14	15	16	17	18	19	20	21	22	23	24	25
Standard control panel	Package ID 46	1	1	1	1	1	1	1	1	1	1	1	1

- Accessories Available as an Option\*

GTS boiler	Number of sections	14	15	16	17	18	19	20	21	22	23	24	25
Burner plate with 165, 186, 210, 240 or 295 ø hole		1	1	1	1	1	1	1	1	1	1	1	1
Smokehood plate with 300 ø opening or plain smokehead plate		1	1	1	1	1	1	1	1	1	1	1	1



### Tools Required:

- JD-TE or JD-TE Plus assembly tool (+ extension for GTS 22 or larger)
  - Flat screwdriver
  - No. 2 Pozidrive screwdriver
  - 10, 13, 16, 17, 18 and 19 mm spanners
  - 22mm tubular box spanner
  - 27 mm tubular box spanner
  - electric screwdriver + No. 2 Phillips bit
  - Stanley knife
  - Silicone filler (supplied)
- **If the boiler is supplied with an assembled body,** start assembly from Frame 22.
  - **Assemble the boiler body from the rear to the front:**
    - assemble the **rear** section,
    - assemble all the **normal intermediate** sections,
    - assemble all the **special intermediate** sections,
    - assemble the **front** section.
- Refer to Frame 11 to 21.

# INSTALLATION

## 10 ASSEMBLY OF VISCOUNT GTS BOILERS - contd

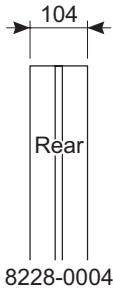
The number of sections of each type is provided in the table below:

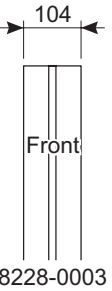
Section Type:	 104 Rear 8228-0004	 111 Normal intermediate 8228-0001	 151 Special intermediate 8228-0002	 104 Front 8228-0003
<b>GTS 14</b>	1	9	3	1
<b>GTS 15</b>	1	10	3	1
<b>GTS 16</b>	1	11	3	1
<b>GTS 17</b>	1	12	3	1
<b>GTS 18</b>	1	13	3	1
<b>GTS 19</b>	1	14	3	1
<b>GTS 20</b>	1	14	4	1
<b>GTS 21</b>	1	15	4	1
<b>GTS 22</b>	1	16	4	1
<b>GTS 23</b>	1	17	4	1
<b>GTS 24</b>	1	18	4	1
<b>GTS 25</b>	1	19	4	1

VIS9135

# INSTALLATION

## 11 BASE FRAME ASSEMBLY

Boilers with 14, 16, 18, 20, 22 and 24 sections

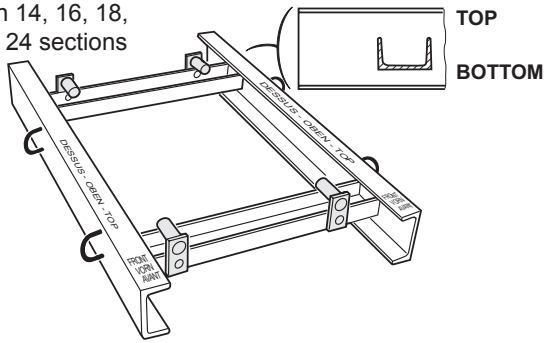

Boilers with 15, 17, 19, 21, 23 and 25 sections

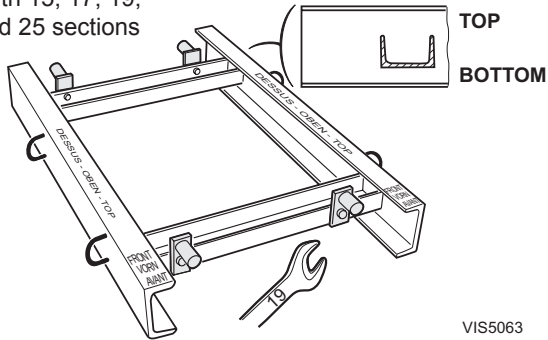

VIS5063

- Place the frame on the floor, taking care to note the TOP and FRONT positions.
- Fit the **fastening brackets** as shown, depending on the type of boiler (one  $\varnothing 12 \times 40$  screw, 19 mm spanner).

## 12 POSITIONING THE REAR SECTION

14, 16, 18, 20, 22 and 24 sections

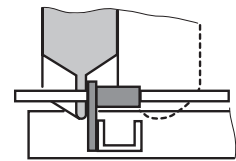

15, 17, 19, 21, 23 and 25 sections

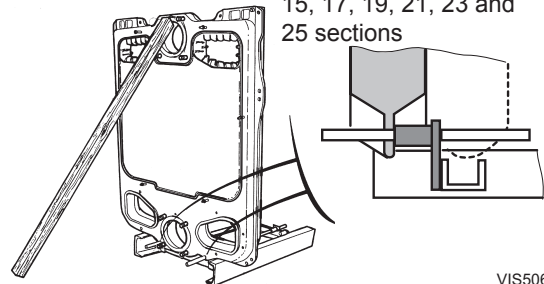

VIS5064

- Establish the location of the frame on the basis of the opening direction of the furnace door and the length of the burner. Leave enough clearance at the rear of the boiler for water connections (see Frame 4) and the distributing tube (see Frame 2 and Frame 32).
- Fit the rear section on the frame, behind the fastening brackets (see detailed drawing) and prop it up.
- Insert the lower assembly rods in the holes of the rear section and the fastening brackets of the frame, in order to position the rear section correctly according to the frame.

## 13 PREPARING THE REAR SECTION

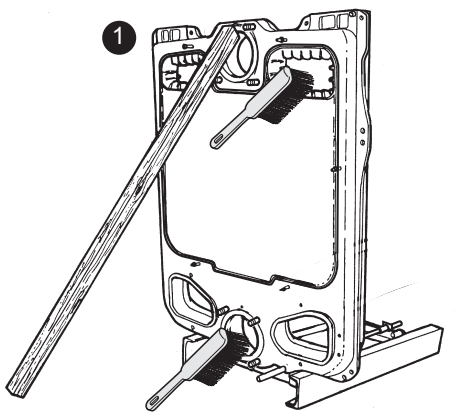

VIS5065

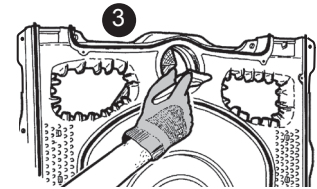
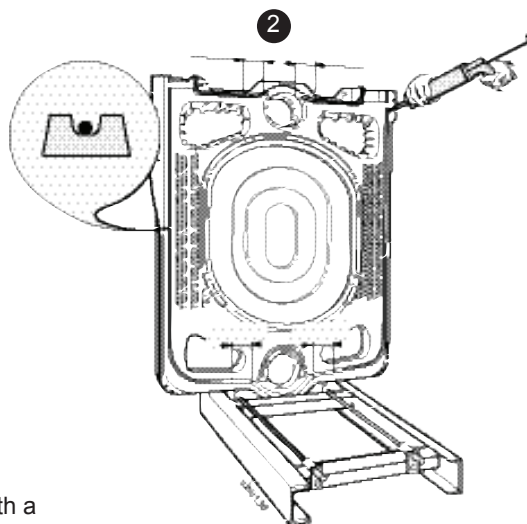

VIS5067

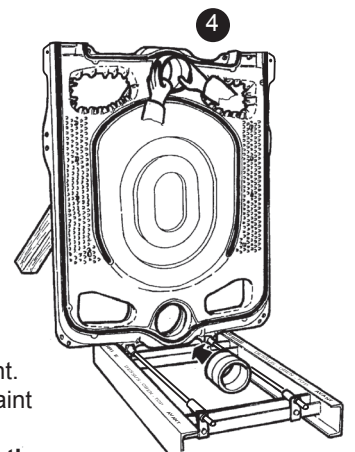

VIS5068

1. Clean all the openings in the section with a brush. Remove any deposit on the bottom of the section.

2. Carefully insert the thermocord in the grooves of the section and retain it in place with silicone filler .

**Note :** do not pull on the seal while inserting it. Otherwise, you may stretch it and reduce its thickness.

3. Clean the bores and nipples with solvent. Remove any traces of rust-protective paint so that the surface is perfectly smooth. **Coat with the lubricant supplied with the sections.**

4. Gently push in the two nipples.

## 14 ASSEMBLING THE NORMAL INTERMEDIATE SECTION

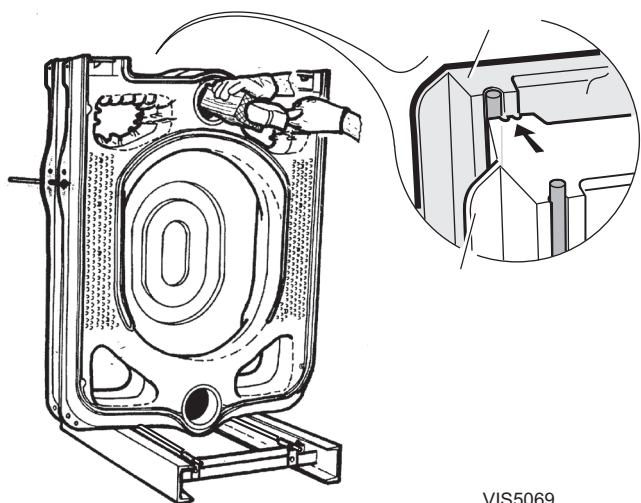

VIS5069

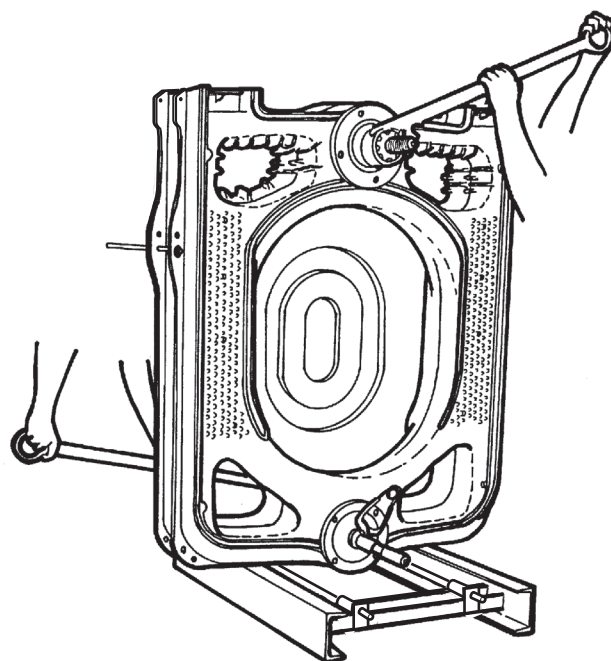

VIS5070

- Place the first normal intermediate section, making sure that it is turned in the right direction, i.e. with the flattening groove against the thermocord.
- For safety, insert a lateral assembly rod (supplied) in the holes of the two sections.
- Push the section gently and simultaneously onto both nipples of the rear section with a hammer and a piece of wood positioned in line with the bores.
- Put the assembly tool in position.  
Tighten gradually so as to bring together the upper and lower connections evenly and simultaneously.

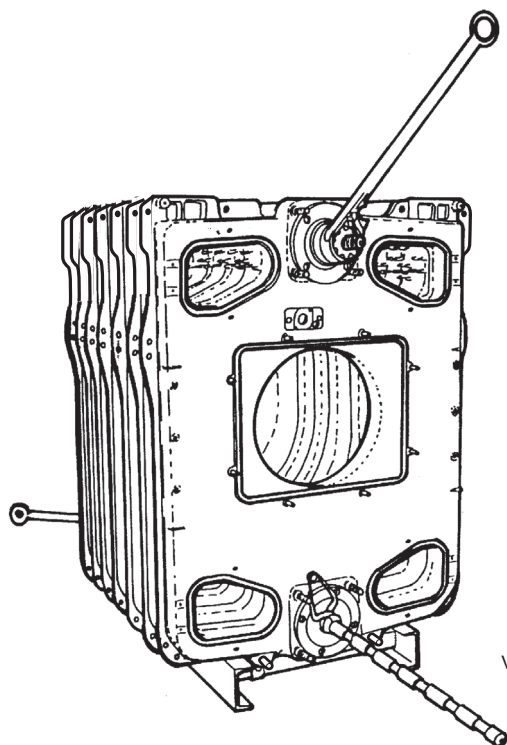

VIS5071

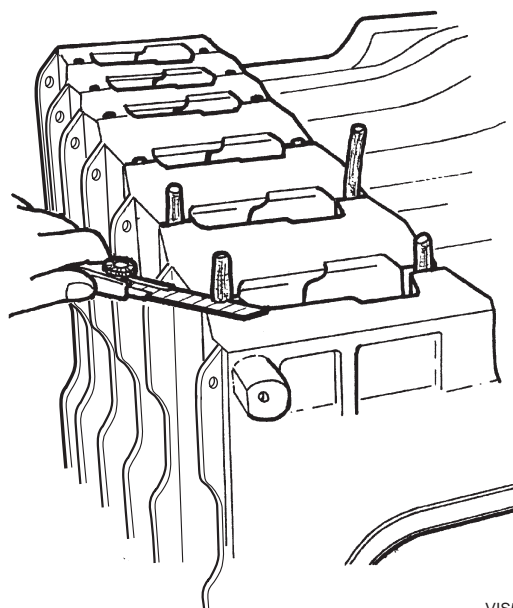

VIS5072

- Assemble the remaining intermediate sections one by one, to the procedure stated in Frames 13 and 14 above.  
First assemble the normal intermediate sections, then the special ones (see page 13 of this booklet).
- Trim off any projecting ends of the thermocords from the sweeping covers.



**Leave the assembly tool in place.**

## INSTALLATION

### 15 FITTING THE UPPER AND LOWER ASSEMBLY RODS

- On the lower assembly rods, fit the following at each end in the given order : an expansion spring, a washer and a nut (the holes of the front lugs must be aligned with the holes of the frame brackets as the assembly rods are used to make the boiler body integral with the frame).
- Stop tightening as soon as the gap between the spring spires is equal to about 2 mm.

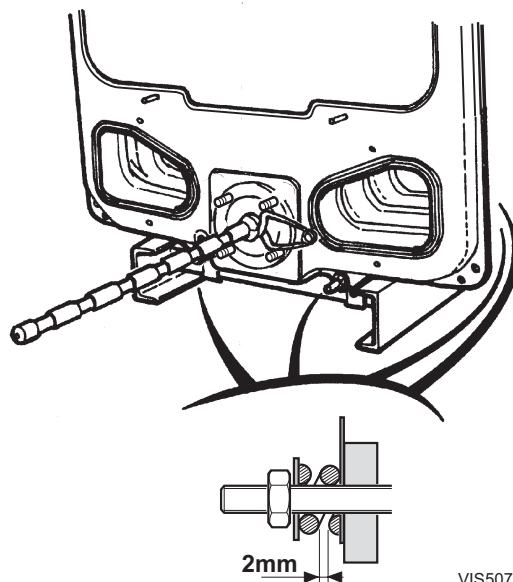

### 16 FITTING THE UPPER AND LOWER ASSEMBLY RODS

- Put in place the upper assembly rods in the two front and rear lugs.
- Mount the two crosspieces (supplied in package **IG84/IG85**) with their bends turned backwards and fasten them to the rods with an expansion spring, a nut and a washer.
- Remove the assembly tool.

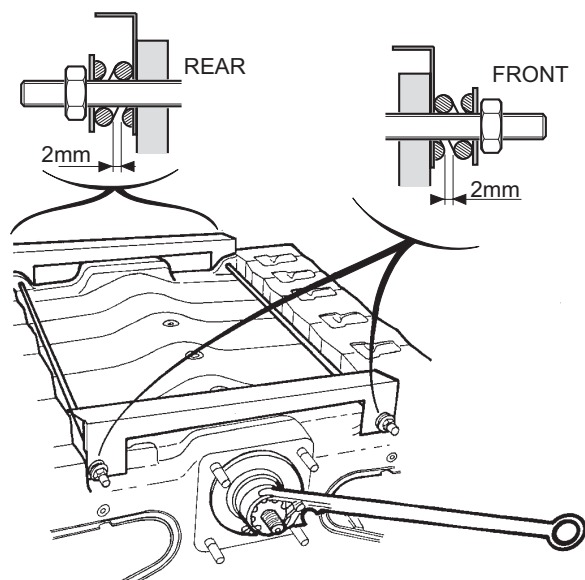



# INSTALLATION

## 17 FITTING OF THE SIDE ASSEMBLY RODS



- The side assembly rods must be assembled from the **rear** to the **front**.
- **The rods must be inserted in the holes stated in the diagrams** (the lugs of the sections in which the assembly rods are to be inserted have two holes).
- Place the expansion spring and washer **on the rear** of each rod.

Stop tightening the nuts as soon as the gap between the spires of the springs is about 1 mm.

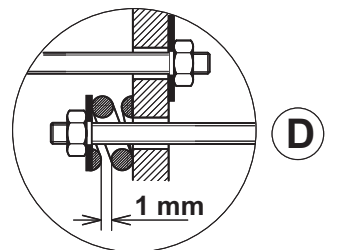
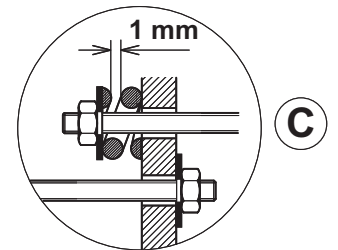
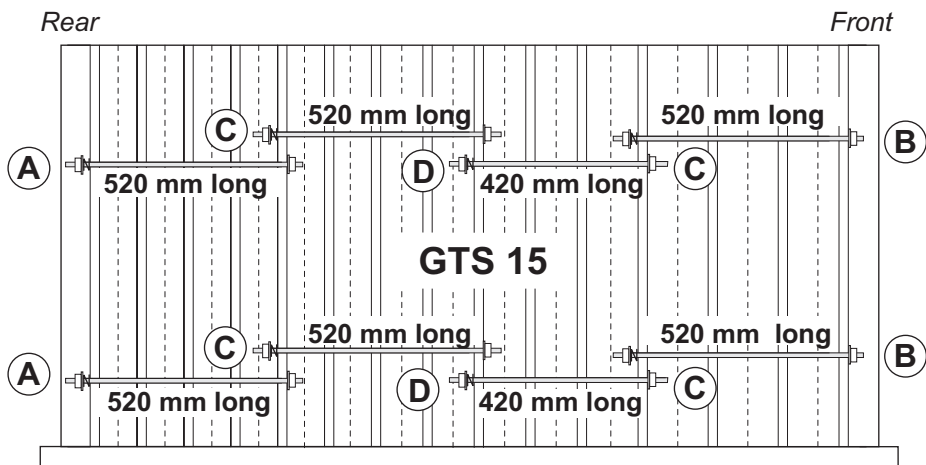
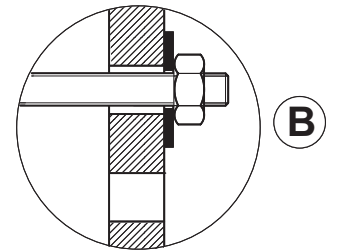
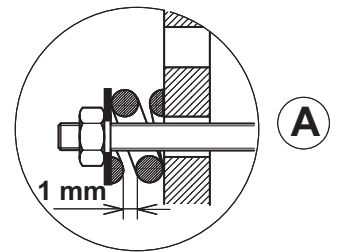
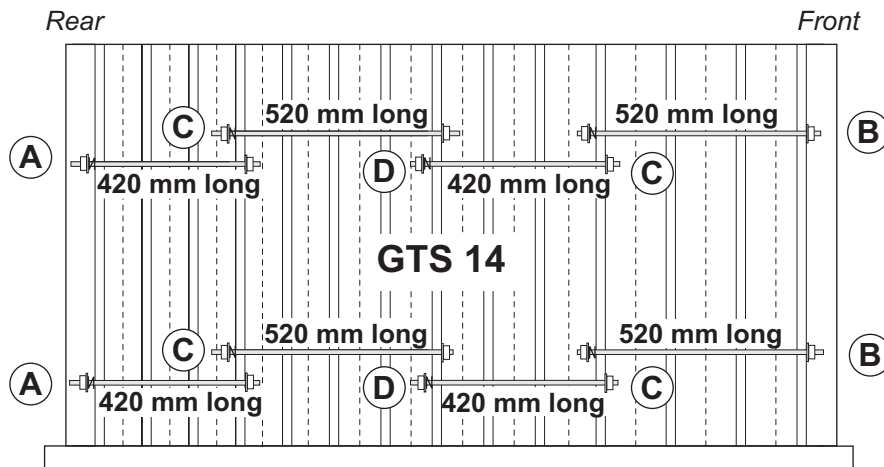

VIS9137

# INSTALLATION

## 18 FITTING OF THE SIDE ASSEMBLY RODS - Cont'd

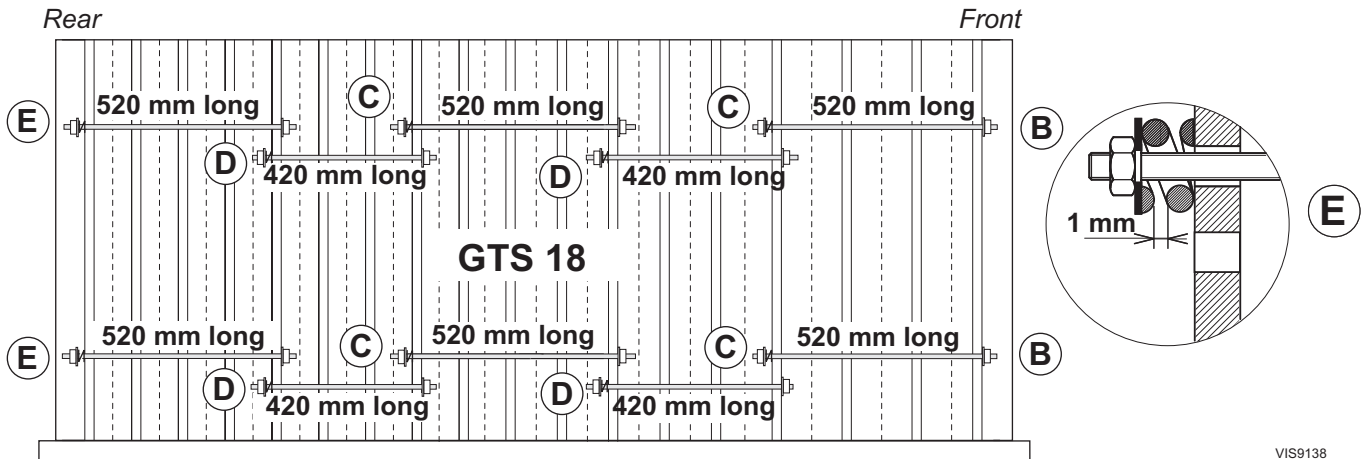
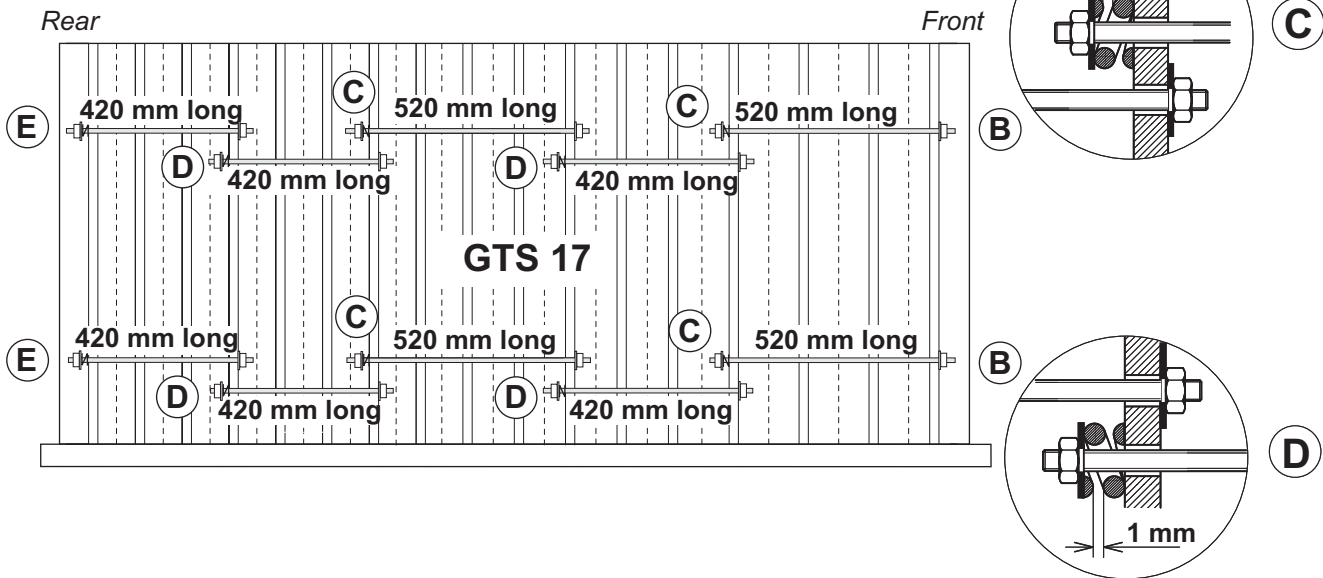
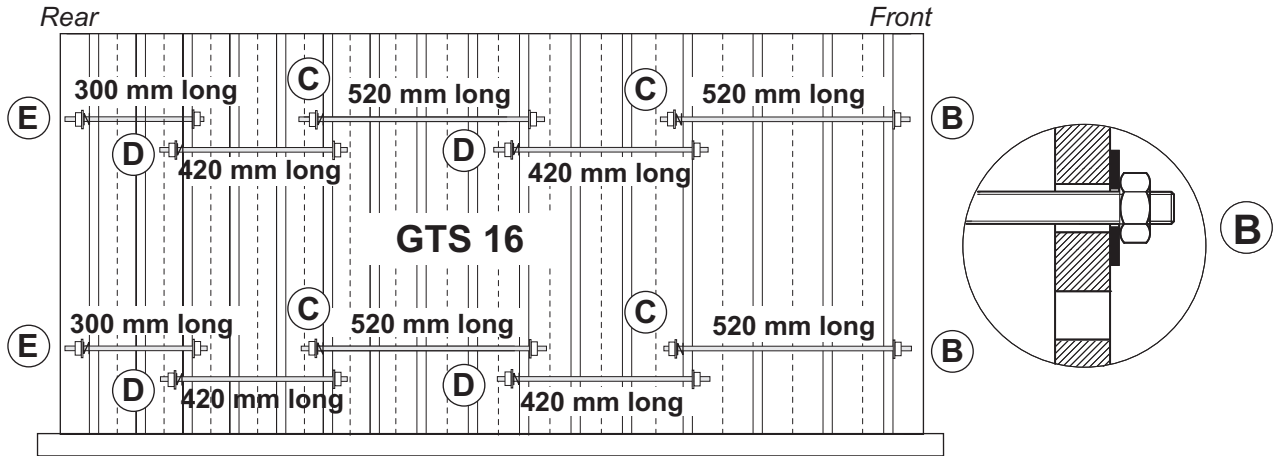

VIS9138

# INSTALLATION

## 19 FITTING OF THE SIDE ASSEMBLY RODS - Cont'd

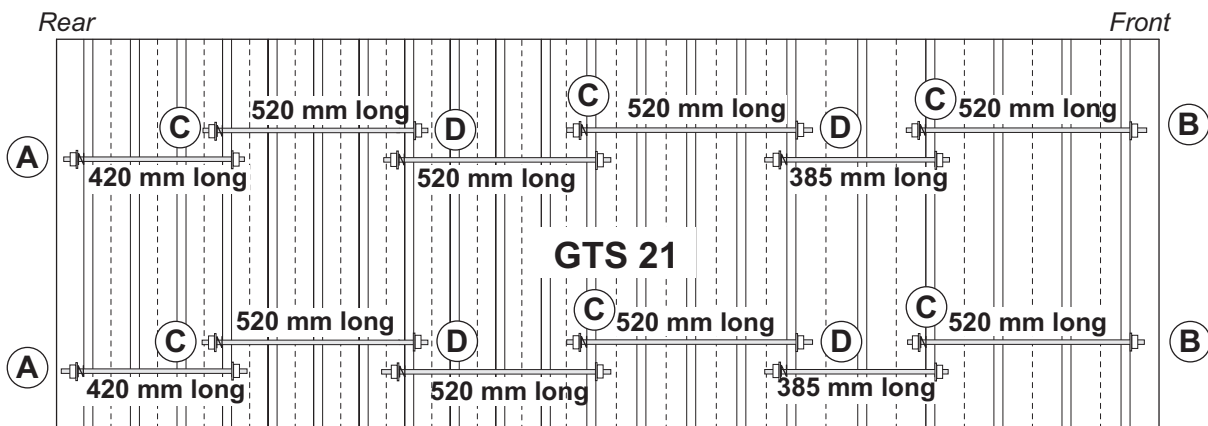
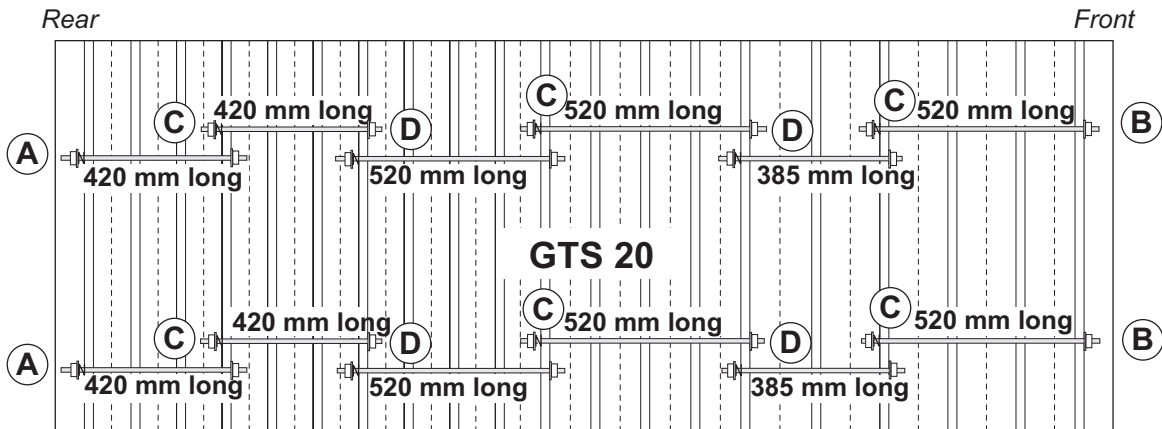
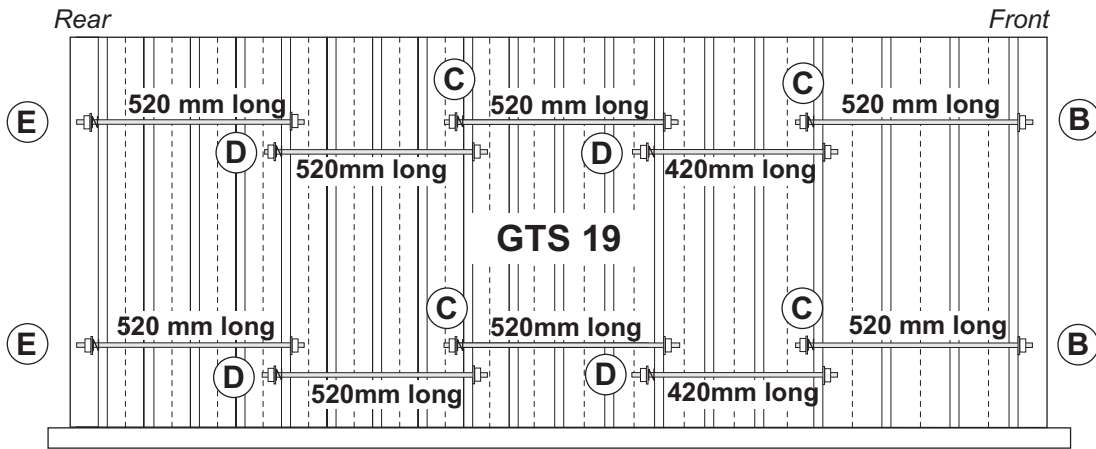
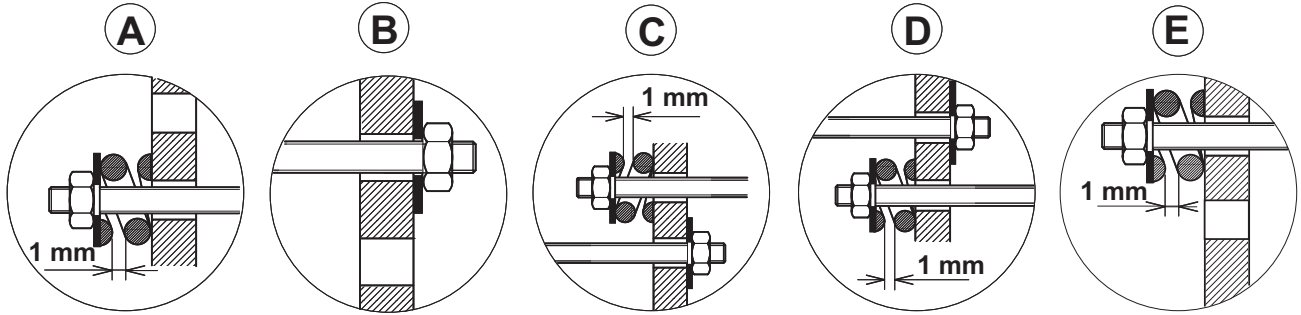

VIS9139

# INSTALLATION

## 20 FITTING OF THE SIDE ASSEMBLY RODS - Cont'd

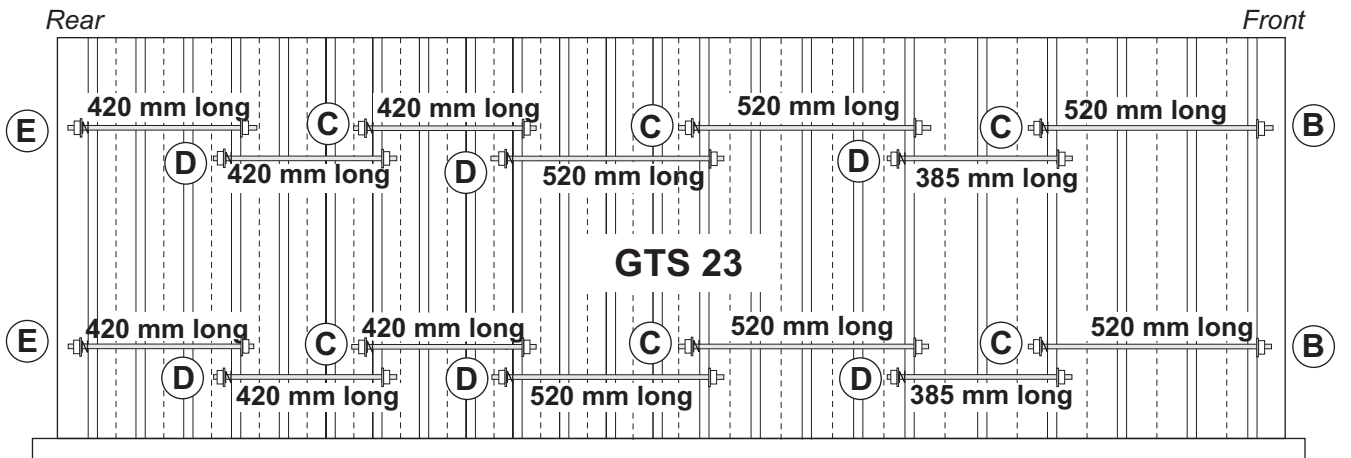
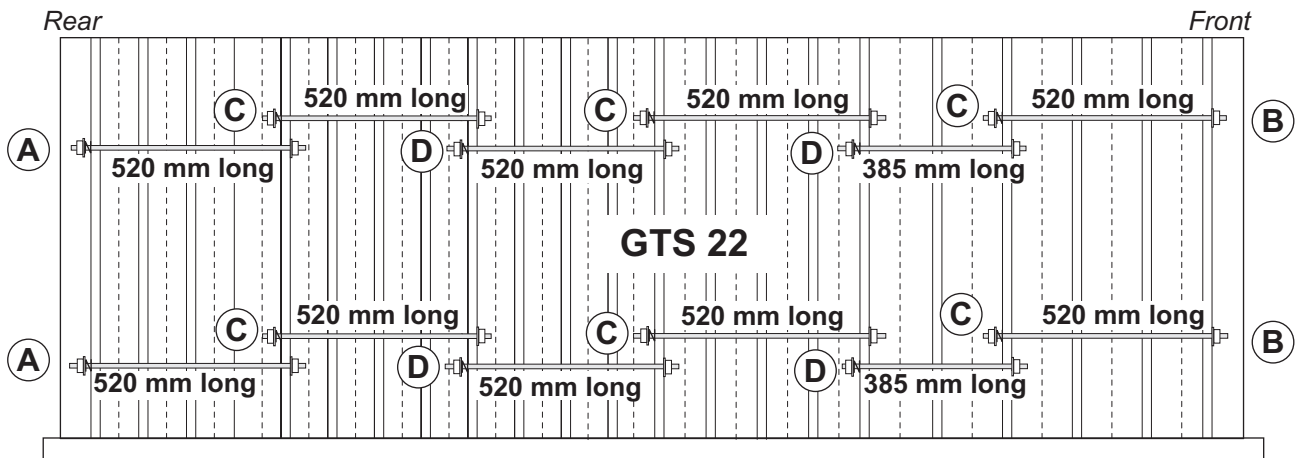
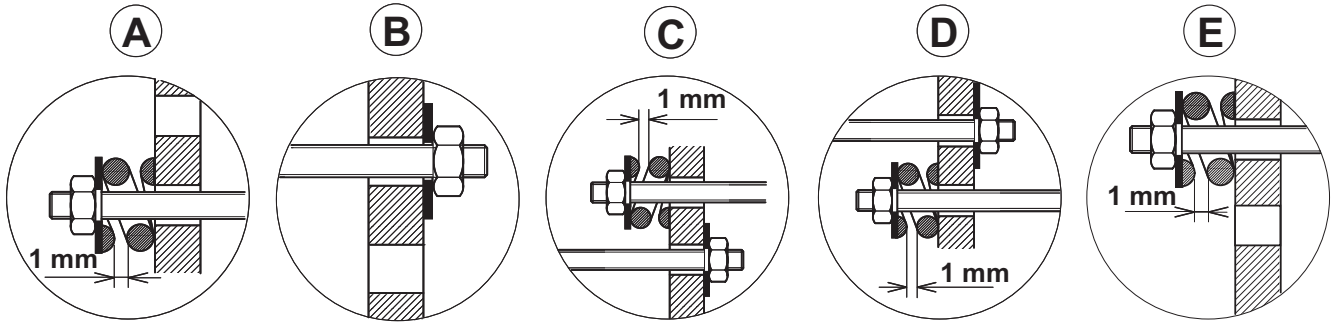

VIS9140

# INSTALLATION

## 21 FITTING OF THE SIDE ASSEMBLY RODS - Cont'd

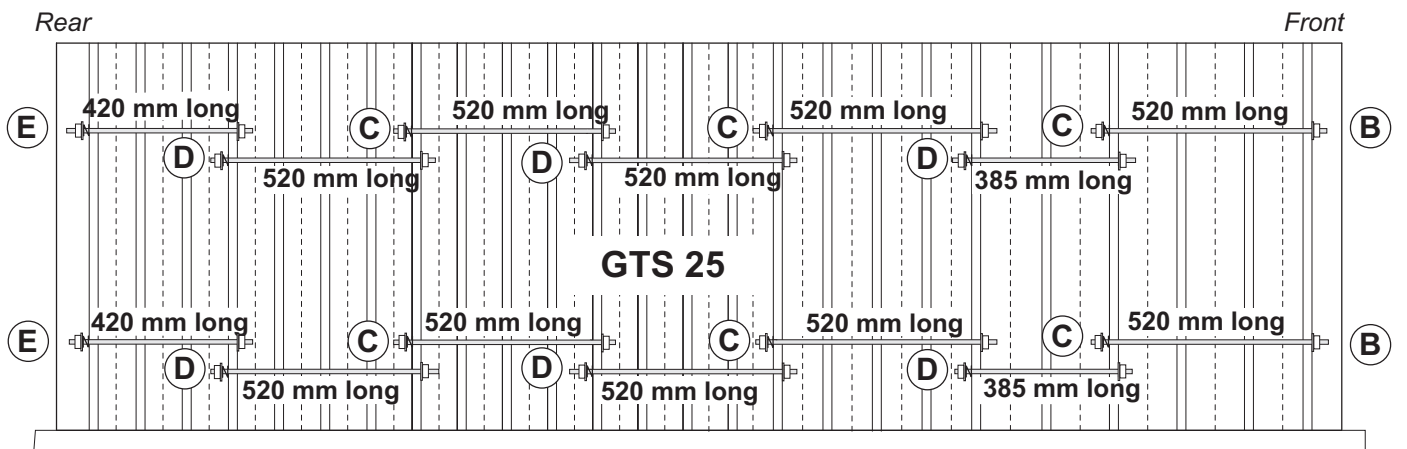
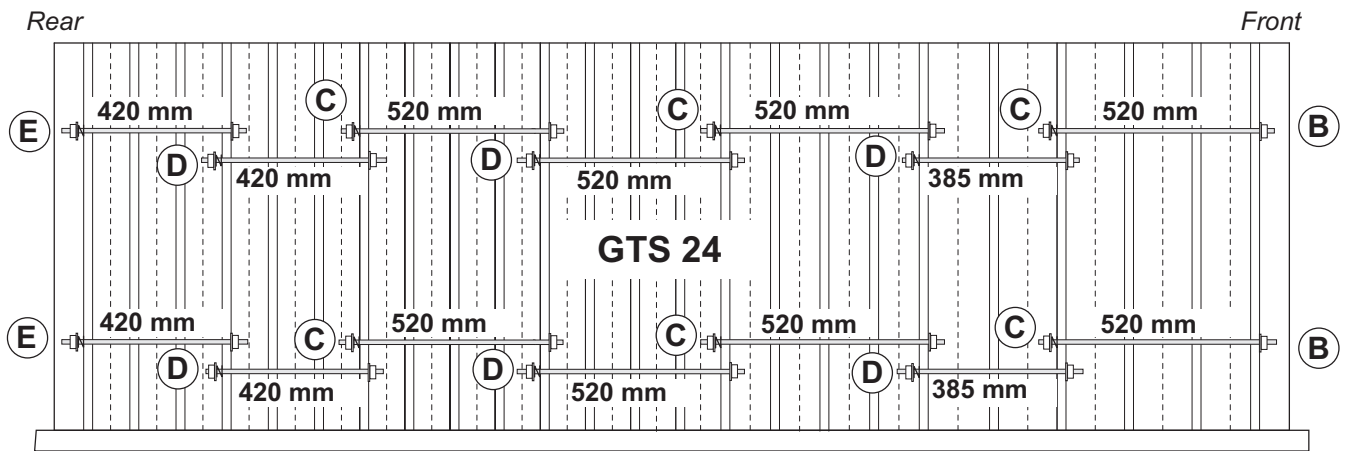
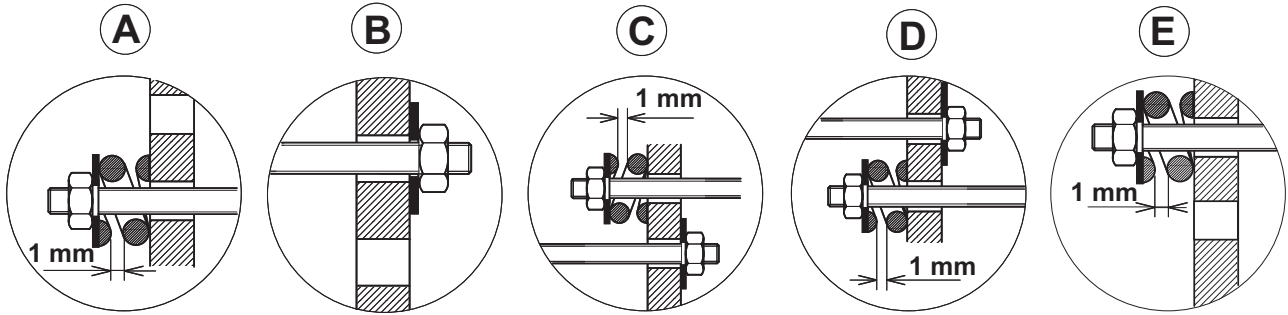

VIS9141

# INSTALLATION

## 22 ASSEMBLE THE POCKET

- Assemble the pocket for the thermostats and thermometer in :
  - the third special intermediate section - 150 mm wide, 1/2" hole (GTS 14 - 19)
  - or
  - the fourth special intermediate section - 150 mm wide, 1/2" hole (GTS 20 - 25).
- Plug the two (GTS 14 - 19) or three (GTS 20 - 25) free 1/2" holes in the special intermediate sections.

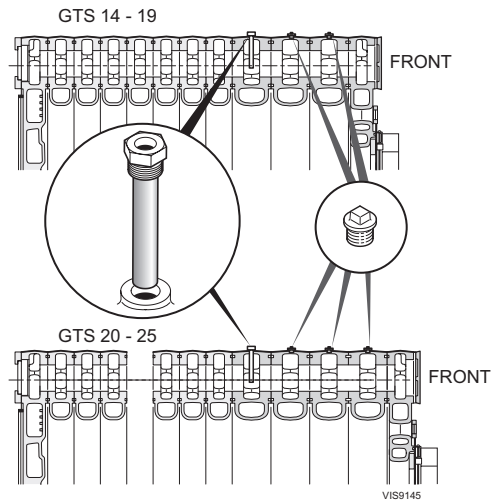

## 23 HYDRAULIC TEST

After assembling the boiler body, the installer must carry out a water tightness test at a hydraulic pressure of 1.5 times the design pressure for a period of 30 minutes. The test must be done at room temperature.

1. Seal off the flow and return connections with blank flanges
2. Fit a suitable supply line with valves and union connection.
3. Fit a suitable valve to vent the boiler. (Temporary only.)
4. Fill the boiler then shut off the supply water.

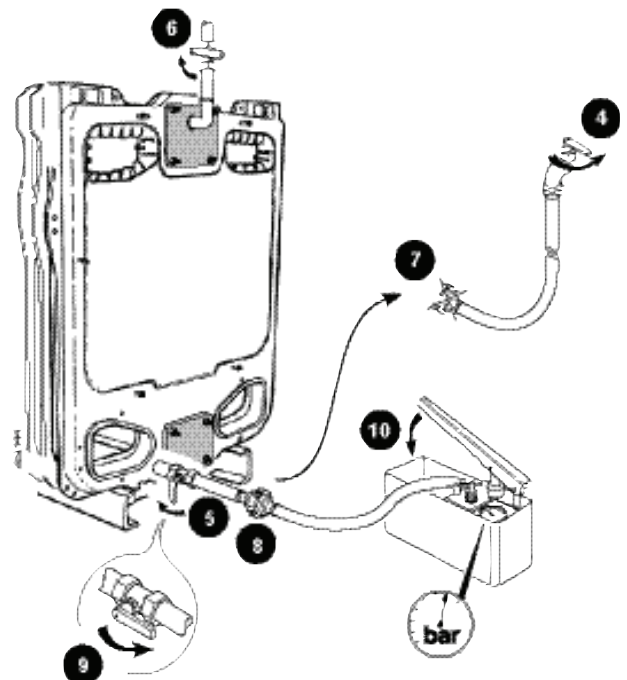
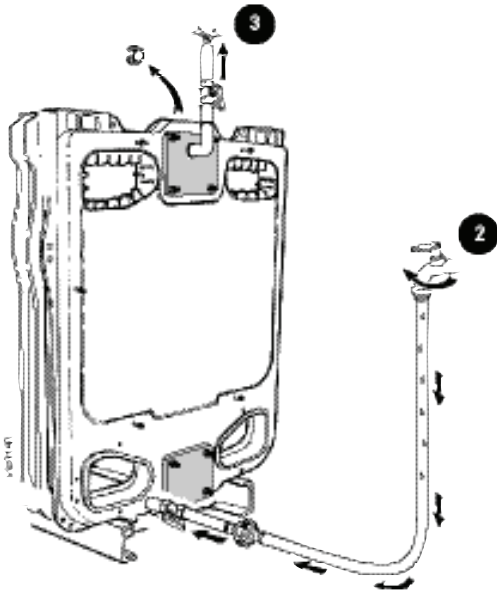
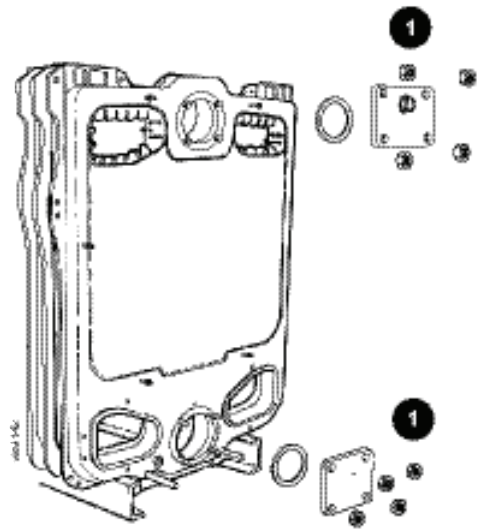

5. Shut off the inlet valve.
6. Close the vent valve.
7. Disconnect the supply water.
8. Connect the pressure system water.
9. Open the fill valve.
10. Pressurise the boiler. Maintain pressure for **30 minutes**.  
Any drop in pressure indicates a leakage in the boiler body.
11. After successfully conducting the test, release the pressure and drain.
12. Remove all parts used for the test.

# INSTALLATION

## 24 ASSEMBLING THE BAFFLE PLATES

Boiler	GTS 14	GTS 15-19	GTS 20-25
Total number of baffle plates	4	6	8
Package no.	CM23	CM22 + CM23	2xCM23

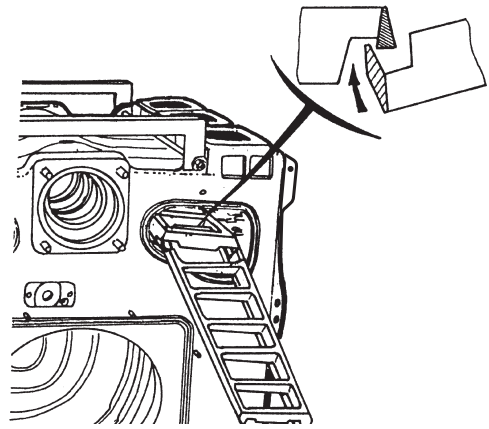

- Put the baffle plates into place in the upper front flue ways, **taking care to interlock them with each other before fitting them.**

## 25 ASSEMBLING THE FLUE CLEANOUT COVERS

- Clean off the protective varnish on the ground surfaces with solvent.
- The covers are numbered from 1 to 4, and must be fitted with a thermocord (1).  
The length of the thermocord depends upon the cover and is given below.

Type	Thermocord Length
1	1335 mm
2	1110 mm
3	890 mm
4	665 mm

Cover Model	No 1	No 2	No 3	No 4
	Number of sweeping covers per type			
Type of Boiler	FRONT ←			→ REAR
GTS 14	2		6	
GTS 15	2	4		2
GTS 16	2	4	2	
GTS 17	2	6		
GTS 18	2	2	6	
GTS 19	2	6		2
GTS 20	2	6	2	
GTS 21	2	8		
GTS 22	2	6	2	2
GTS 23	2	6	4	
GTS 24	2	8	2	
GTS 25	2	10		

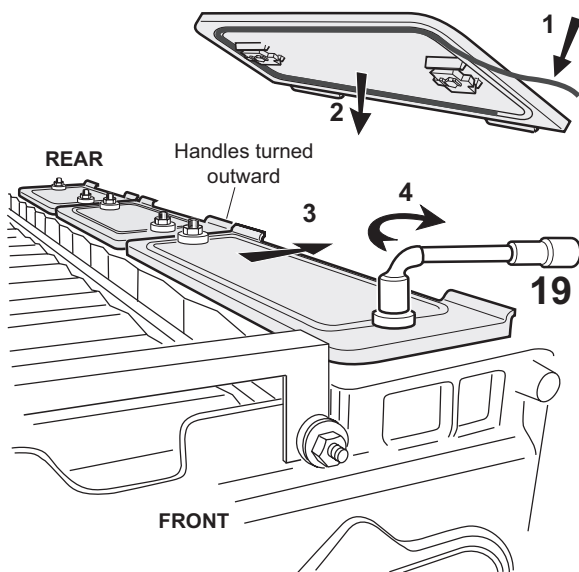

VIS5081

- Place the two no. 1 cleanout covers (with the handles turned outward) on either side of the boiler starting from the front. Distribute the other covers evenly.
- Each cover is fitted with a system whereby it can only be mounted with the handles turned outward.
- Fit the two locks of each cover between the sections.
- Push the cover towards the outside of the boiler, to the "closed" position (1).
- Fasten the two brass nuts of each cover (4).



# INSTALLATION

## 26 FITTING THE TRAP DOORS

- Insert the thermocord in the sealing groove on each side and hold it in place with a few drops of silicone filler.
- Insert the thermocord in the sealing groove of the two lower flue ways, on the rear and front of the boiler.
- Put the four trap doors on the lower flue ways and fasten with the wing nuts.

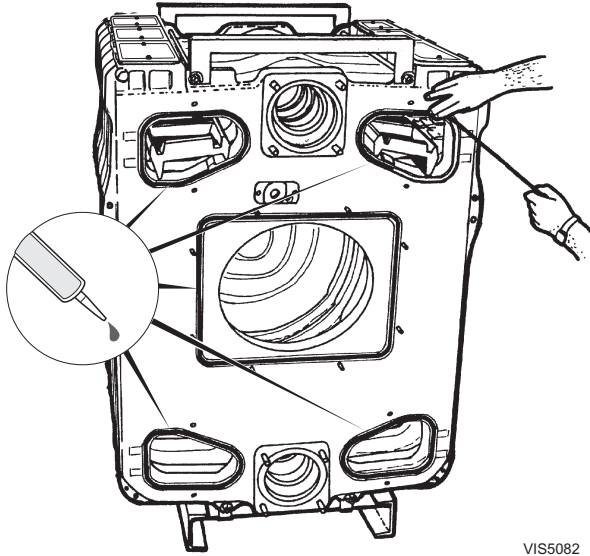

VIS5082

Front and Rear

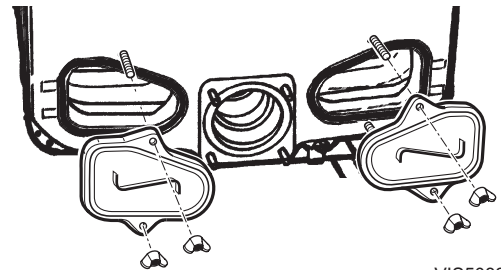

VIS5083

## 27 ASSEMBLING THE FURNACE DOOR

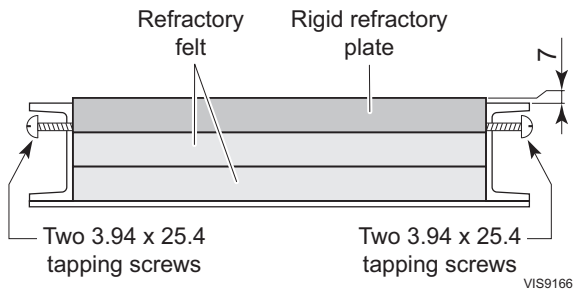

VIS9166

- Put the furnace door insulating material in place and retain it with the four 3.94 x 25.4 tapping screws.

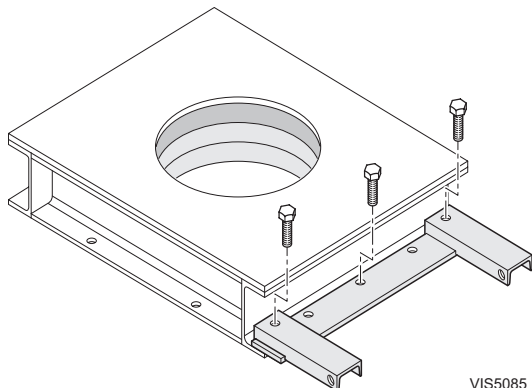

VIS5085

- Place the furnace door on the floor and fasten the articulation onto the door with three M12 screws.

## 28 INSTALLING THE HINGE OF THE FURNACE DOOR

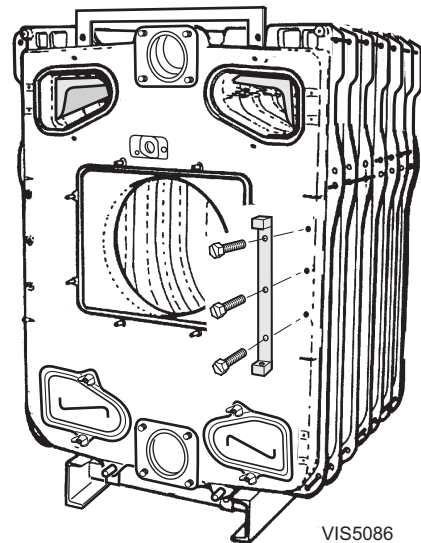

VIS5086

- Fix the furnace door hinge on the right or left-hand side of the front section by means of three M12 x 25 screws.



# INSTALLATION

## 29 INSTALLING THE HINGE OF THE FURNACE DOOR - Cont'd

- Fit the door onto the hinge by inserting the pin (1).

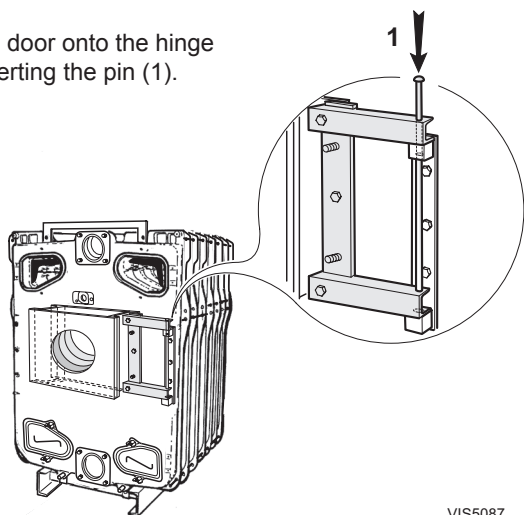

VIS5087

- Close the furnace door on the 8 studs and fasten with 8 washers and nuts (2).

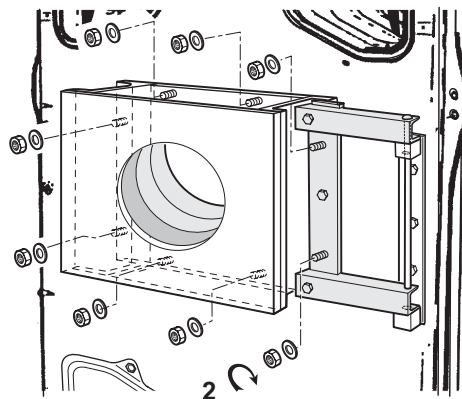

VIS5088

## 30 FITTING THE FLUEWAY DOORS

- Fit the two doors of the upper flue ways (wing nuts).
- Fit the plain flange onto the upper connection of the front section (using four M18 nuts), with the 170 x 222 gasket in between (first soak the gasket in warm water).
- Fit the flange with the sludge removal hole onto the lower connection of the front section (hole in the lower part of the flange) using four M18 nuts, with the gasket in between (soak in warm water first).

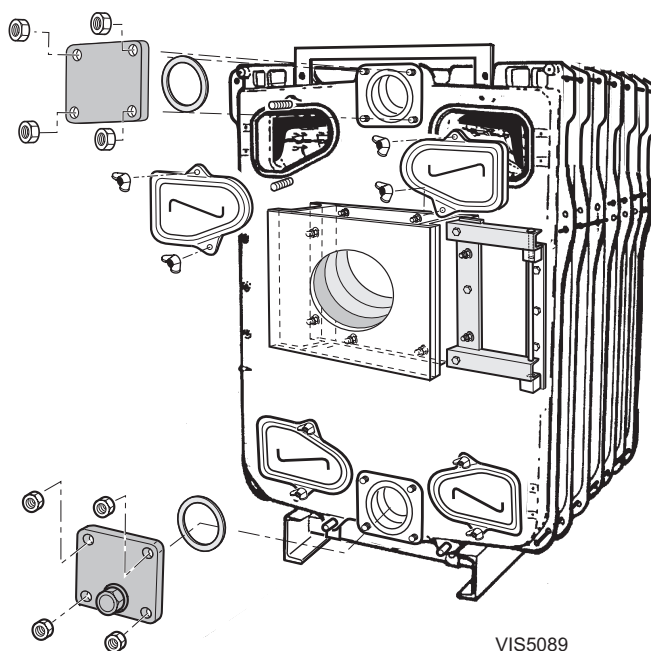

VIS5089

## 31 FLAME INSPECTION WINDOW

The flame inspection window is fitted with a 1/4" tapped hole for ventilation (optional) :

- if a ventilation system is used, connect the hole to the one provided for that purpose before the burner combustion head.

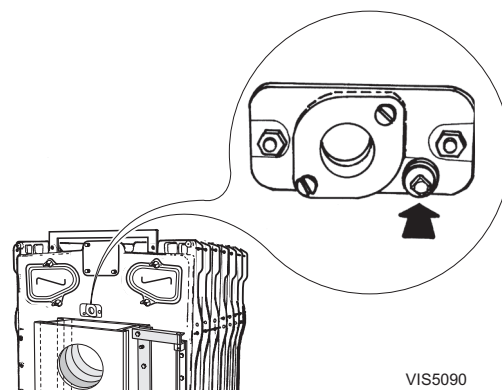

VIS5090

### 32 ASSEMBLING THE RETURN FLANGE ON BOILERS GTS 14-25

Boiler Type	L (mm)
GTS 15, 16	380
GTS 17-19	600
GTS 20-22	880
GTS 23-25	1210

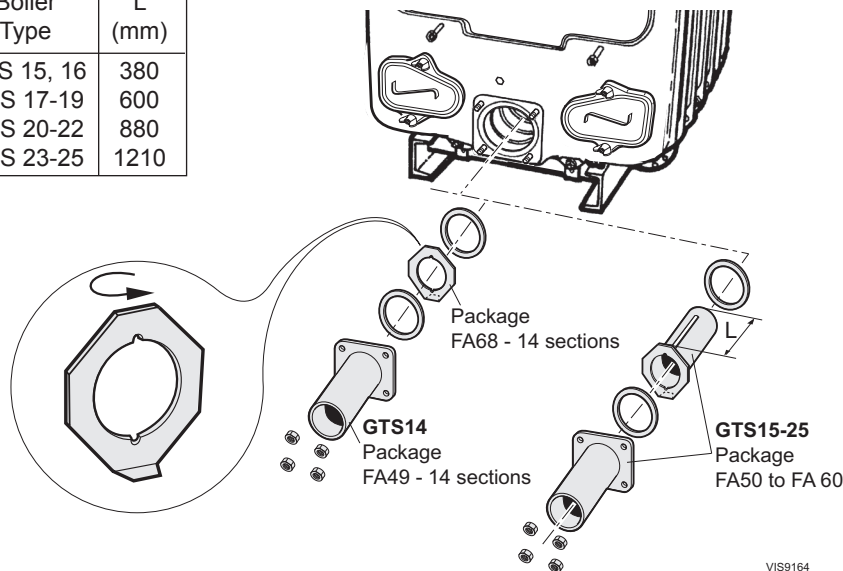

**GTS 14:**

Fit the water balancing diaphragm with the notches vertical onto the boiler return with a  $\varnothing$  170 x 222 gasket in between (first soak the gasket in warm water).

Fit the heating return flange with a  $\varnothing$  170 x 222 gasket in between and fix it with four M18 nuts.

**GTS 15 - GTS 25 :**

Fit the water balancing tube onto the boiler return with a  $\varnothing$ 170 x 222 gasket in between (first soak the gasket in warm water), using four M18 nuts.

Fit the heating return flange with a  $\varnothing$  170 x 222 gasket in between (first soak the gasket in warm water) and fix it with four M18 nuts.

### 33 FITTING THE BOILER OUTLET FLANGE GTS 14 - GTS 25

**GTS 14 - GTS 15**  
Package FA 49 to FA 50

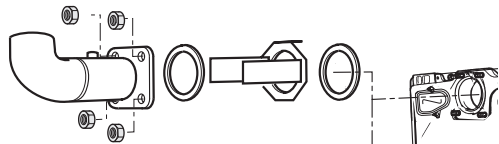

**GTS 16 - GTS 25**  
Package FA 51 to FA 60

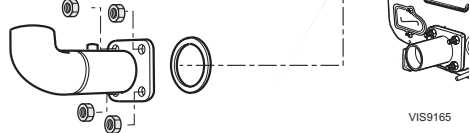

• **GTS 14 - 15 :**

Place the nozzle turned outside from the boiler with a  $\varnothing$  170 x 222 gasket in between (first soak the seal in warm water).

Assemble the flange with angled piece so that the angle is turned upward, with a  $\varnothing$  170 x 222 gasket in between (first soak the gasket in warm water) and fasten with four M18 nuts.

• **GTS 16 - 25 :**

Assemble the flange with angled piece so that the angle is turned upward, with a  $\varnothing$  170 x 222 gasket in between (first soak the gasket in warm water) and fasten with four M18 nuts.

### 34 FITTING THE BOILER OUTLET FLANGE

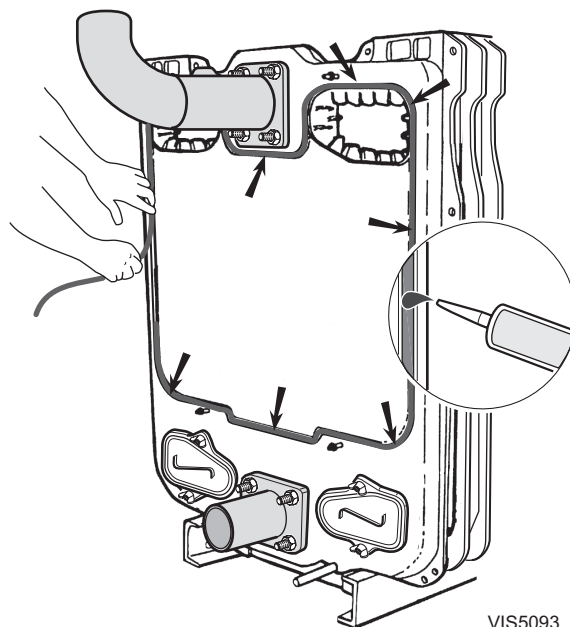

Carefully insert the  $\varnothing$  15 gasket in the groove of the rear section and hold it in place with a few drops of silicone.

### 35 PREPARING THE SMOKEHOOD

Before assembling the smokehood, grease all bolts, studs and screws with high temperature grease (not supplied).

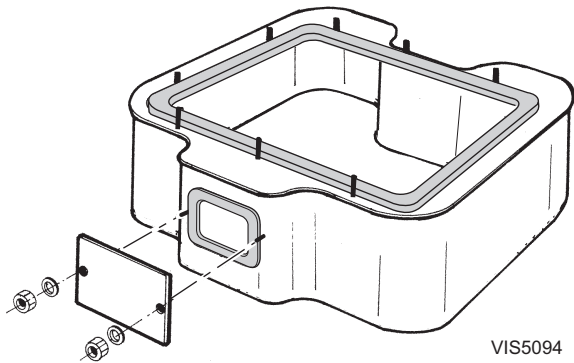

- Put the flat adhesive seal in place on the smokehood.
- Put the sweeping cover in place and fasten with two M10 nuts and 10  $\emptyset$  washers.

### 36 FITTING THE SMOKEHOOD

Before assembling the smokehood, grease all bolts, studs and screws with high temperature grease (not supplied).

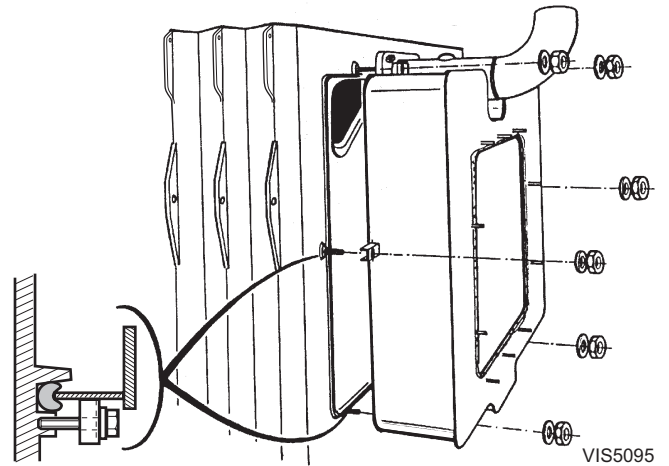

- The flue gas outlet is fastened to the rear by means of six studs, washers and M12 nuts.

### 37 ASSEMBLING THE FLUE OUTLET

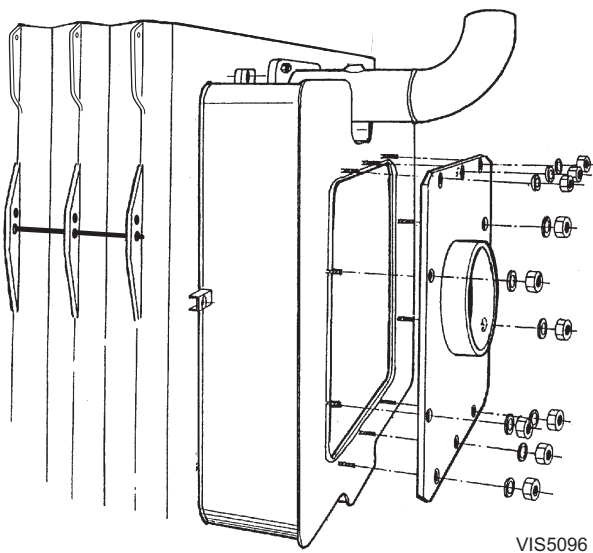

- First adapt the steel connecting plate to the chimney connection flue. Then fasten that plate or the plate with a connecting piece supplied as an option with ten M10 nuts and  $\emptyset$  10 washers.

### 38 ASSEMBLING THE FLOW SWITCH

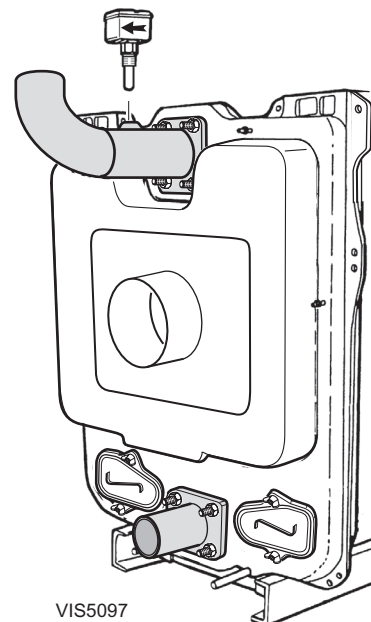

- Screw the flow switch home onto the sleeve.  
(Package IG87 - 98)

The direction of the arrow on the casing shows the direction of the flow of water in the pipe.

# INSTALLATION

## 39 ASSEMBLING THE BAFFLE PLATES

Assembling the baffle plates (for boilers supplied with an assembled body only) in boilers supplied with an unassembled body, the baffle plates are already in place.

Boiler	GTS 14	GTS 15 - 19	GTS 20 - 25
Total number of baffle plates	4	6	8
Package no.	CM 23	CM22 + CM23	2xCM23

- Put the baffle plates in place in the upper front flue ways, taking care to interlock them with each other before fitting them.

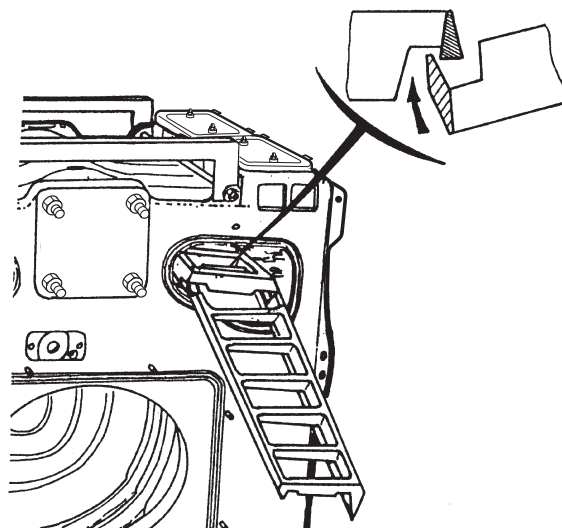

VIS5098

## 40 ASSEMBLING THE CABLE CHANNELS (14-17 SECTIONS)

- Place the cable channels so that their bevelled end is to the front.
- Fasten with two M8 x 16 screws + washers in the third hole starting from the front and opposite the special nut.
- Fasten at the rear with two M8 x 16 screws + washers opposite the oblong holes and special nut.

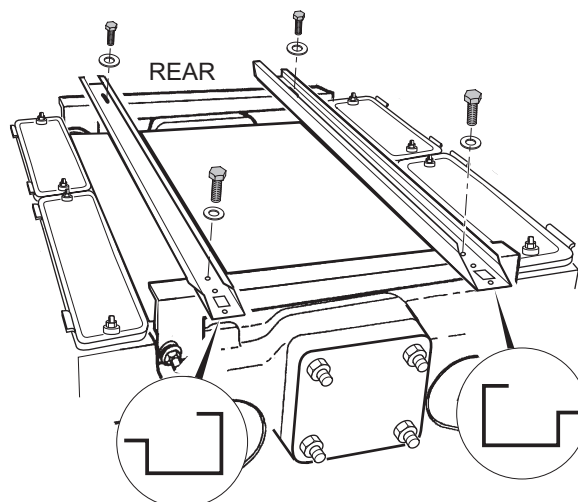

VIS5101

# INSTALLATION

## 41 ASSEMBLING THE TOP INSULATING MATERIAL (14-17 SECTIONS)

- Put in place the 600 mm wide (packages **FA 34 - 36**) top insulating material on the body of the boiler.

No. of Sections	14	15, 16	17
Length (mm)	1800	2100	2200

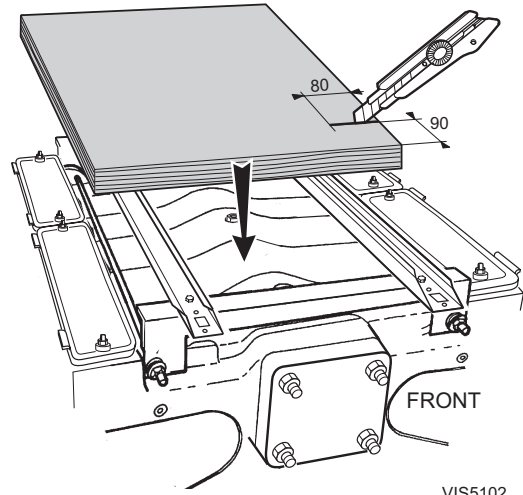

VIS5102

## 42 ASSEMBLING THE CABLE CHANNELS AND CROSSPIECES (18-25 SECTIONS)

- Assemble the intermediate piece on the assembly rods by fitting one slotted side onto one rod and using the flexibility of the other rod.
- Place the two cable channels so that their bevelled end is to the front.
- Fasten the channels to the front crosspiece with two M8 x 16 screws + washers in the third hole starting from the front and opposite the special nut.
- Fasten the cable channels on the intermediate piece with two M8 x 16 screws + washers.

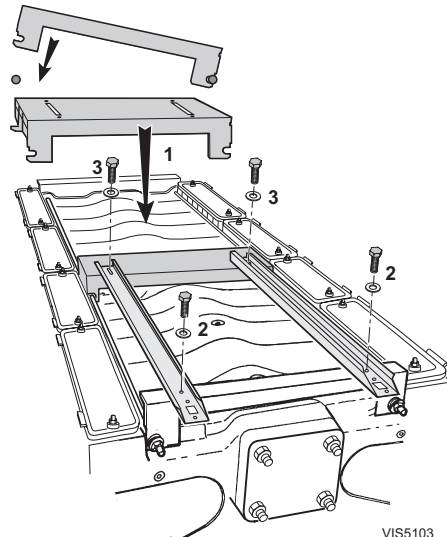

VIS5103

## 43 ASSEMBLING THE ADDITIONAL CABLE CHANNELS (18 - 25 SECTIONS)

No. of Sections	18	19	20	21	22	23	24	25
A (mm)	2510	2600	2800	2910	3000	3110	3200	3310

- Align the two additional cable channels with the two others.
- Fasten them to the intermediate piece and the rear crosspieces with four M8 x 16 screws and washers.

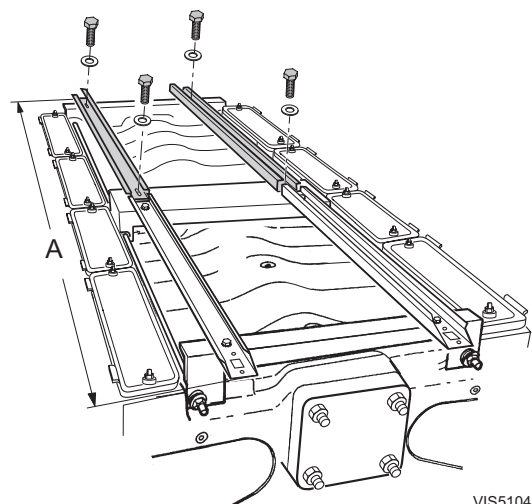

VIS5104

#### 44 ASSEMBLING THE TOP INSULATING MATERIAL

- Put in place the two 600 mm wide (packages **FA 37 - 41**) pieces of insulating material on the body of the boiler.
- Push the insulating material under the front and rear crosspieces.

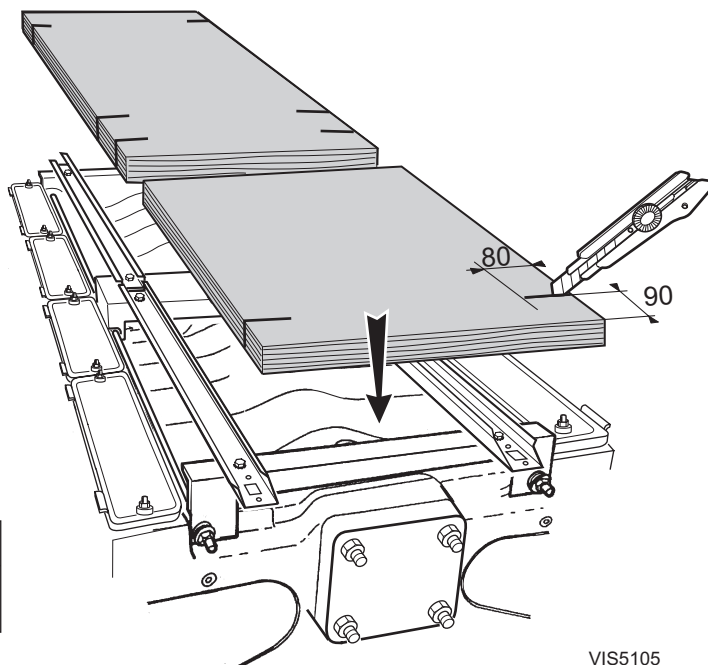

VIS5105

No. of Sections	18	19	20	21	22	23	24	25
Length (mm)	2 x 1200	2 x 1200	2 x 1300	2 x 1400	2 x 1400	2 x 1500	2 x 1500	2 x 1600

#### 45 ASSEMBLING THE CASING POSITIONING BRACKETS

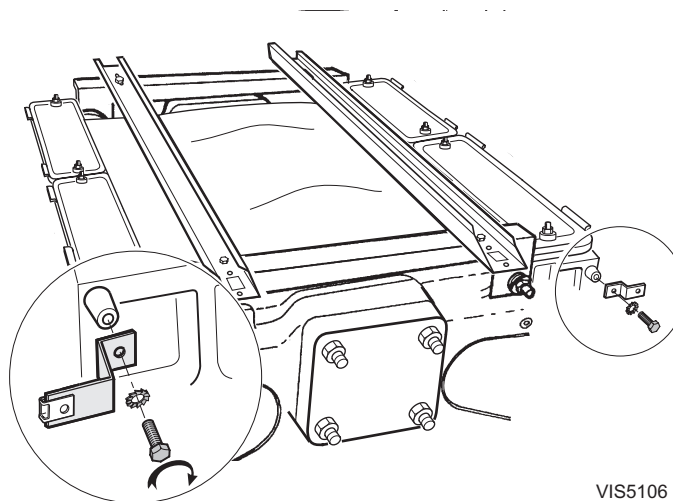

VIS5106

- Fasten the positioning brackets (package **IG84 or IG85**) onto the right and left-hand upper bosses of the front section with two M8x16 screws and two serrated washers (13 mm spanner).

## 46 ASSEMBLING THE LOWER RAIL SUPPORT BRACKETS

Example : GTS 14

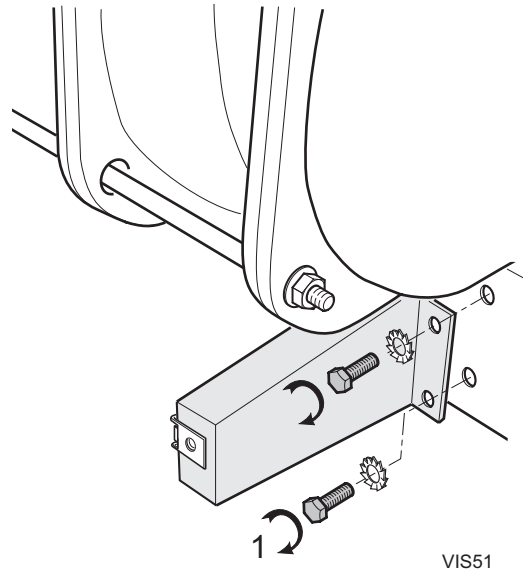

- Fasten the lower rail support brackets using M8 x 16 screws.

**Note:** for the assembly direction, see the drawings below.

## 47 ASSEMBLY DIRECTION OF LOWER RAIL SUPPORT BRACKETS

(seen from the top of the frame)

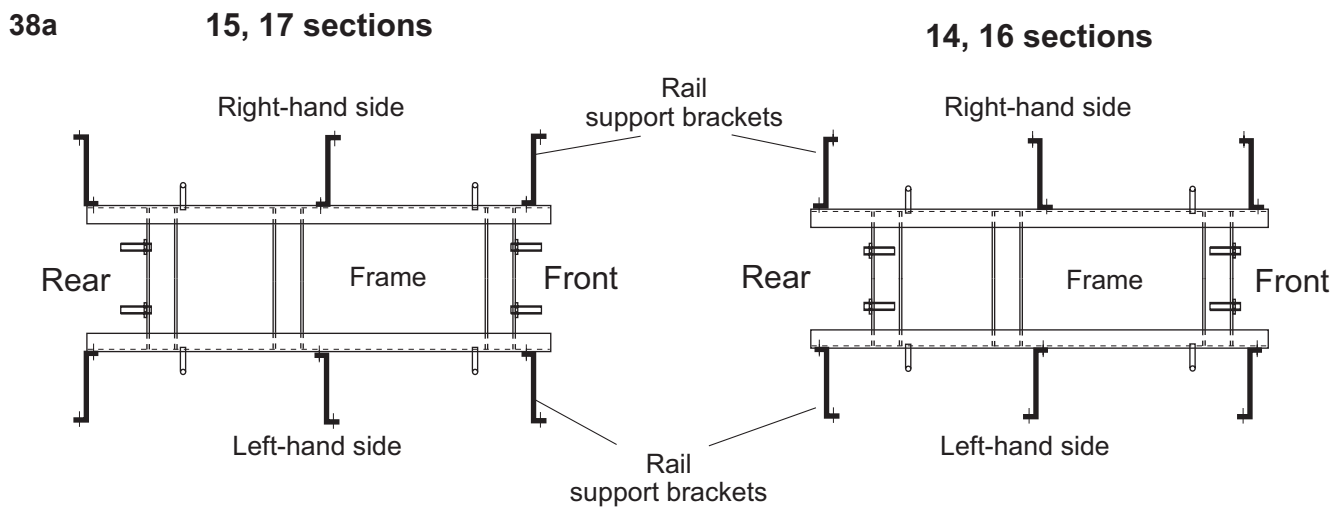

VIS5108

# INSTALLATION

## 48 ASSEMBLING THE TOP INSULATING MATERIAL - Cont'd

(seen from the top of the frame)

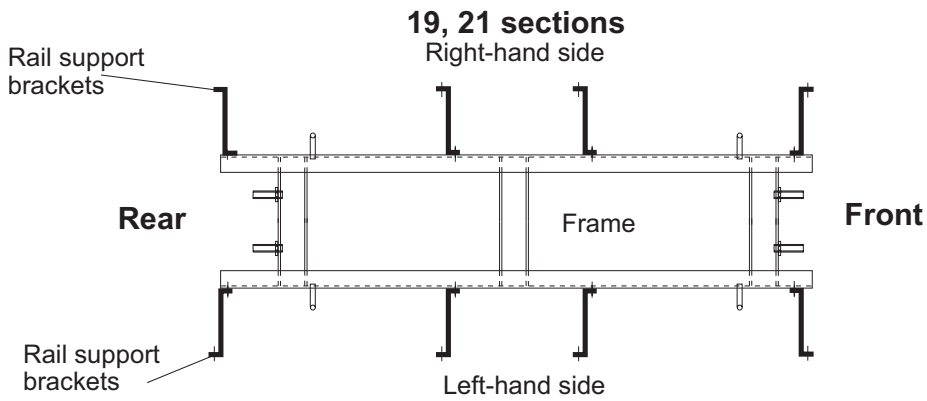
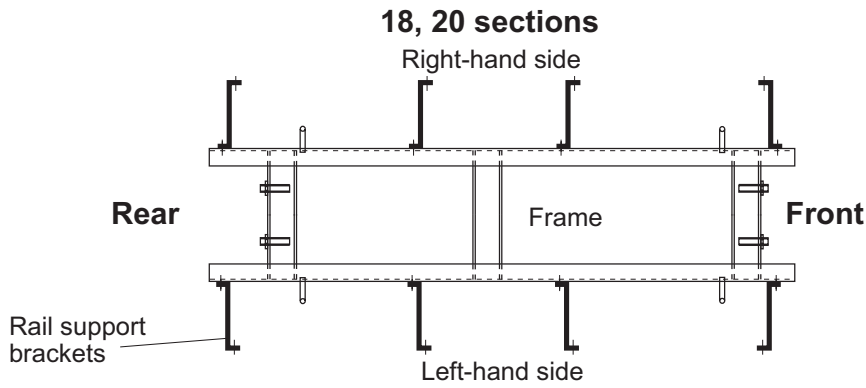

**Note:** two lower rail support brackets and two upper rail brackets are left unused with 18, 19, 20 and 21 sections.

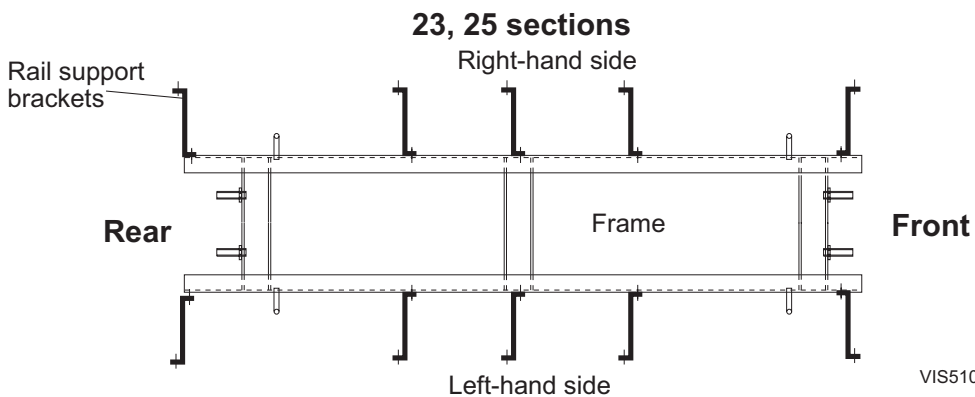
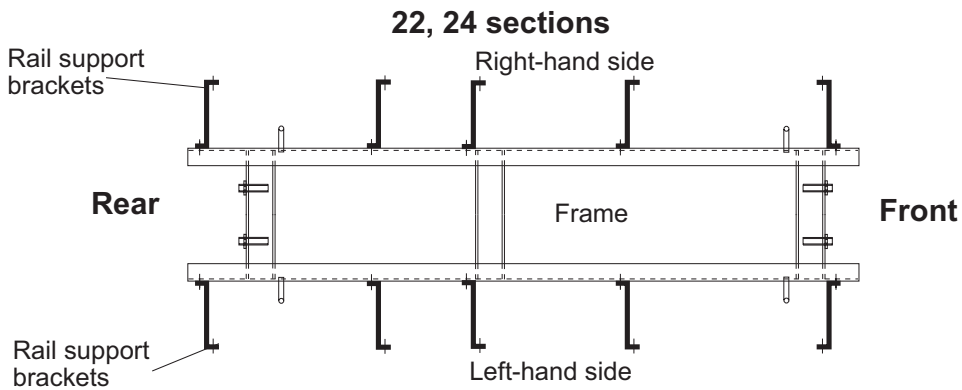

VIS5109



# INSTALLATION

## 49 ASSEMBLING THE JACKET SUPPORTS

- Fasten the lower rail with M8x30 screws and washers.
- The other rail support brackets are fastened opposite the holes provided on the lower rail.

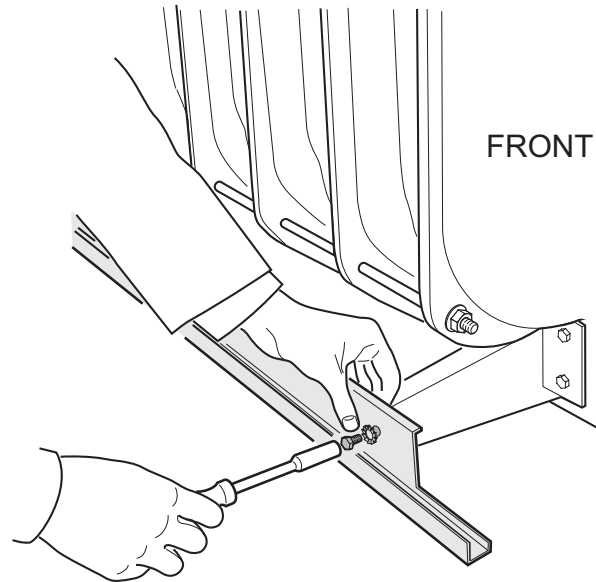

Length required while assembling the two-piece rails (boilers with 18 - 25 sections) (see Frame 52)

VIS5110

## 50 ASSEMBLY DIRECTION OF LOWER RAIL SUPPORT BRACKETS (SEEN FROM THE TOP OF THE FRAME)

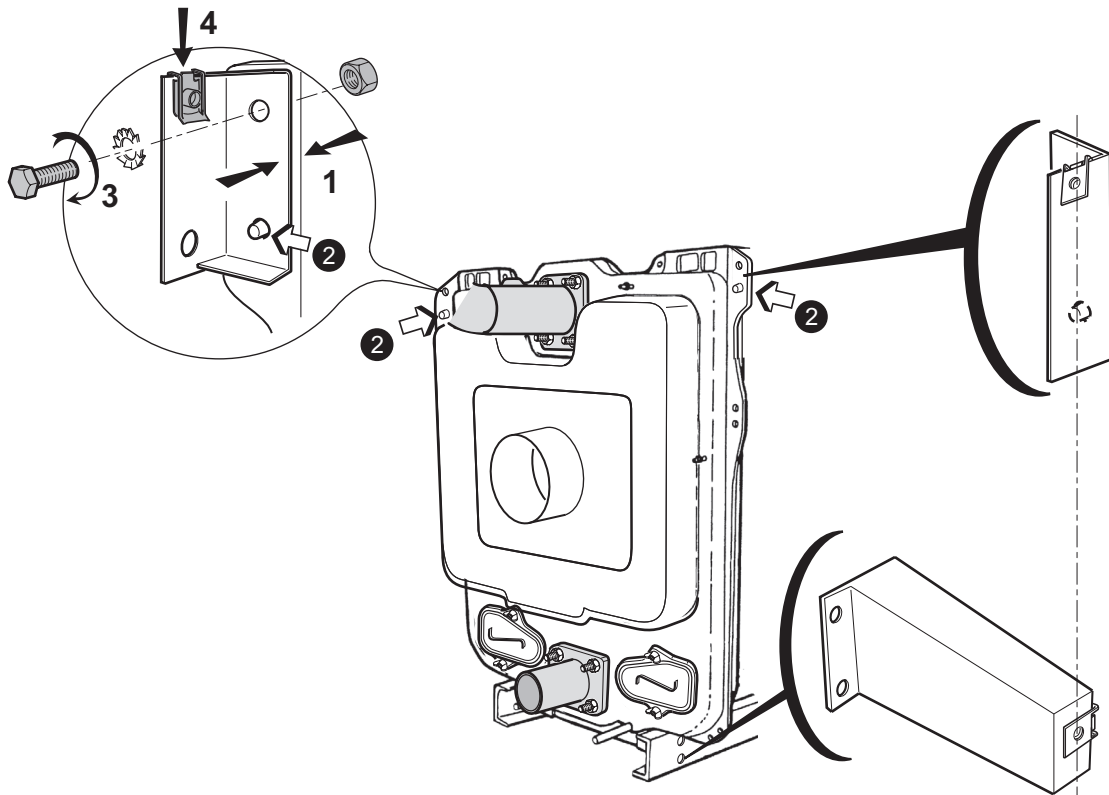

VIS9146

- Fix the fastening bracket of the upper rails (package **IG84** or **IG85**) on the upper lug (1) (**these brackets must be vertically aligned with the lower rail support brackets**).

Fit the bracket onto the stub (2).

- Fasten with M10x50 screws and serrated washers and M10 nuts (3).
- Assemble the Rapid nut on the top of the bracket (4) with the tapped shaft on the inside.

# INSTALLATION

## 51 INSTALLING THE INSULATING MATERIAL

Type of Boiler	FRONT ← → REAR Side insulating material (length in mm)			
	GTS 14	1200	600	
GTS 15	1200	400	400	
GTS 16	1200	400	600	
GTS 17	1200	400	600	
GTS 18	1200	1200		
GTS 19	1200	1200		
GTS 20	1200	400	400	600
GTS 21	1200	400	1200	
GTS 22	1200	400	1200	
GTS 23	1200	600	1200	
GTS 24	1200	600	1200	
GTS 25	1200	400	400	1200

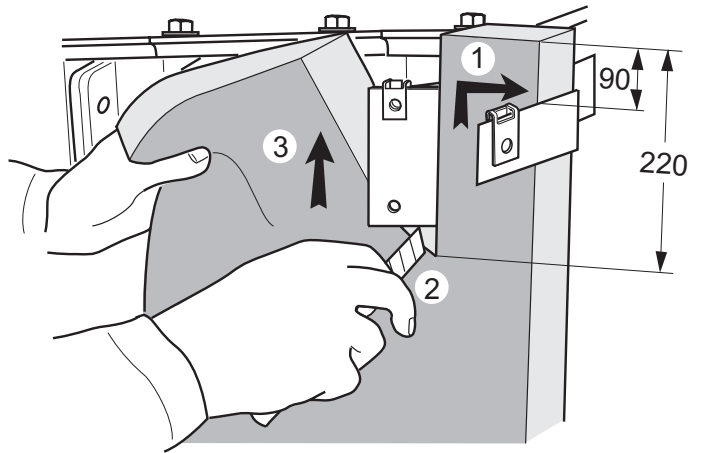

VIS5112

- Place the side insulating material against the positioning bracket (1) and cut it so that it is flush with the upper lug on which the rail fastening bracket is fixed, along a 220 mm length (2).
- (3) Push the insulating material in behind the lug and the rail fastening bracket.
- Distribute the insulating material evenly so that you have the same side insulating material on either side of the boiler.
- Cut the material similarly along the fastening brackets.

## 52 FITTING THE UPPER RAILS

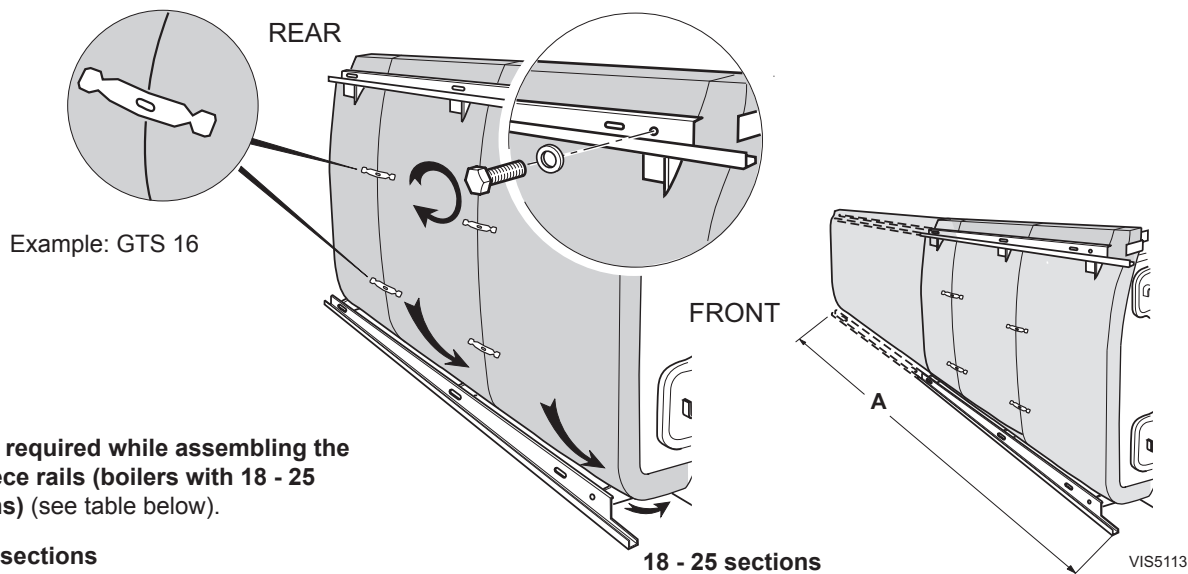

VIS5113

**Length required while assembling the two-piece rails (boilers with 18 - 25 sections)** (see table below).

### 14 - 17 sections

- Fix the upper rail with M8 x 30 screws and washers (the first hole from the front end of the rail must be opposite the first fastening bracket, and similarly with the other brackets).
- Push the insulating material behind the lower rail and underneath the boiler.
- Join the pieces of insulating material to each other with the clips.

### 18 - 25 sections

- Fix the upper rail with M8 x 30 screws and washers (the first hole from the front end of the rail must be opposite the first fastening bracket, and similarly with the other brackets).
- Fix the additional upper and lower rails, making sure you comply with dimension A (see table below).
- Push the insulating material behind the lower rail and underneath the boiler. Join the pieces of insulating material to each other with the clips.

No. of Sections	18	19	20	21	22	23	24	25
A (mm)	2500	2615	2765	2875	2965	3075	3165	3275

# INSTALLATION

## 53 ASSEMBLING THE SIDE CASING PANELS

Length and arrangement of panels for the boiler model

Type of Boiler	FRONT → REAR				
	Side Panels Length in mm				
GTS 14	800	600	600		
GTS 15	940	600	600		
GTS 16	1050	600	600		
GTS 17	940	600	400	400	
GTS 18	1050	600	400	400	
GTS 19	940	600	600	400	
GTS 20	940	600	600	600	
GTS 21	1050	600	600	600	
GTS 22	940	600	600	400	400
GTS 23	1050	600	600	400	400
GTS 24	940	600	600	600	400
GTS 25	1050	600	600	600	400

400 mm long panel in Package FA10  
 600 mm long panel in Package FA11  
 800 mm long panel in Package MR 3  
 940 mm long panel in Package MR4  
 1050 mm long panel in Package MR5

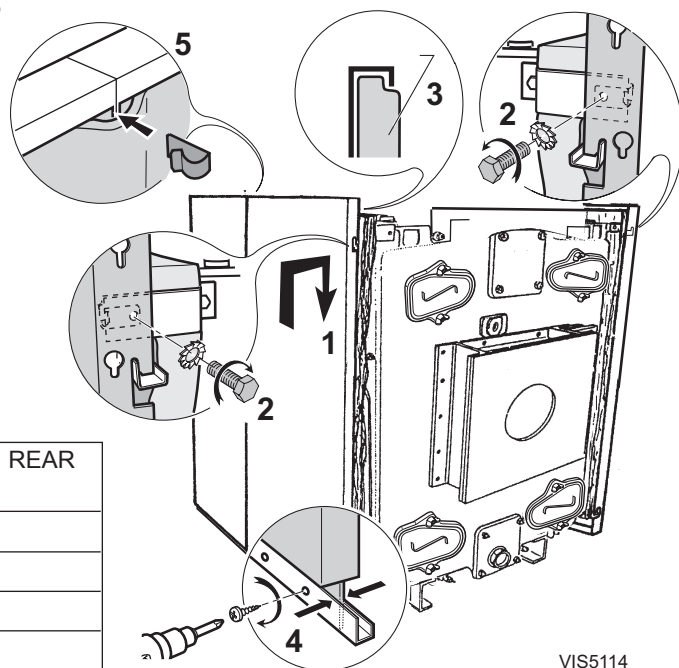

VIS5114

- **First assemble the panels on the front** using the assembly length table opposite and continue up to the rear section (1).
- **Fix the front side panels** to the positioning brackets with M8 x 16 screws and serrated washers (2).
- Push the insulating material into the top of the side panels and fasten the panels (3) to the lower rails by means of the self-tapping screws with the electric screwdriver (2 screws per panel) (4).
- Fasten the side panels to each other with the clips (5).

## 54 ASSEMBLING THE FURNACE DOOR AND LOWER CROSSPIECE PANELS

- Put the **furnace door panel** in place (package **IG84** or **IG85**) and fasten with two  $\varnothing 3.94 \times 12.7$  tapping screws. The furnace door panel may be cut in two at the micro-joints.
- Fit two Rapid nuts in the bottom of the front side panels.
- Fix the **casing support lower crosspiece** (package **IG84** or **IG85**) by means of two M6x20 screws and two serrated washers.

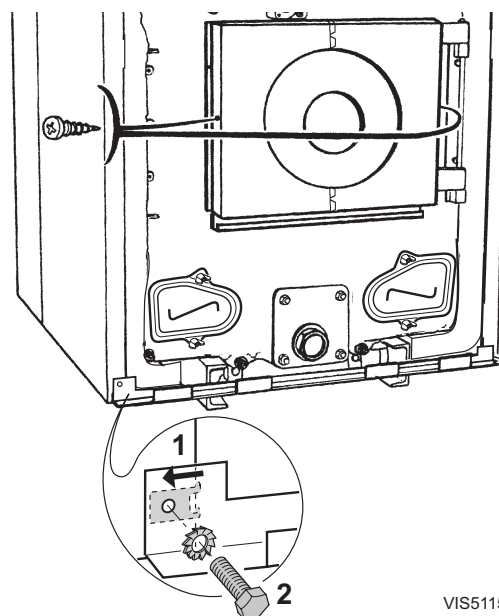

VIS5115

## INSTALLATION

### 55 ASSEMBLING THE CONTROL PANEL BRACKET

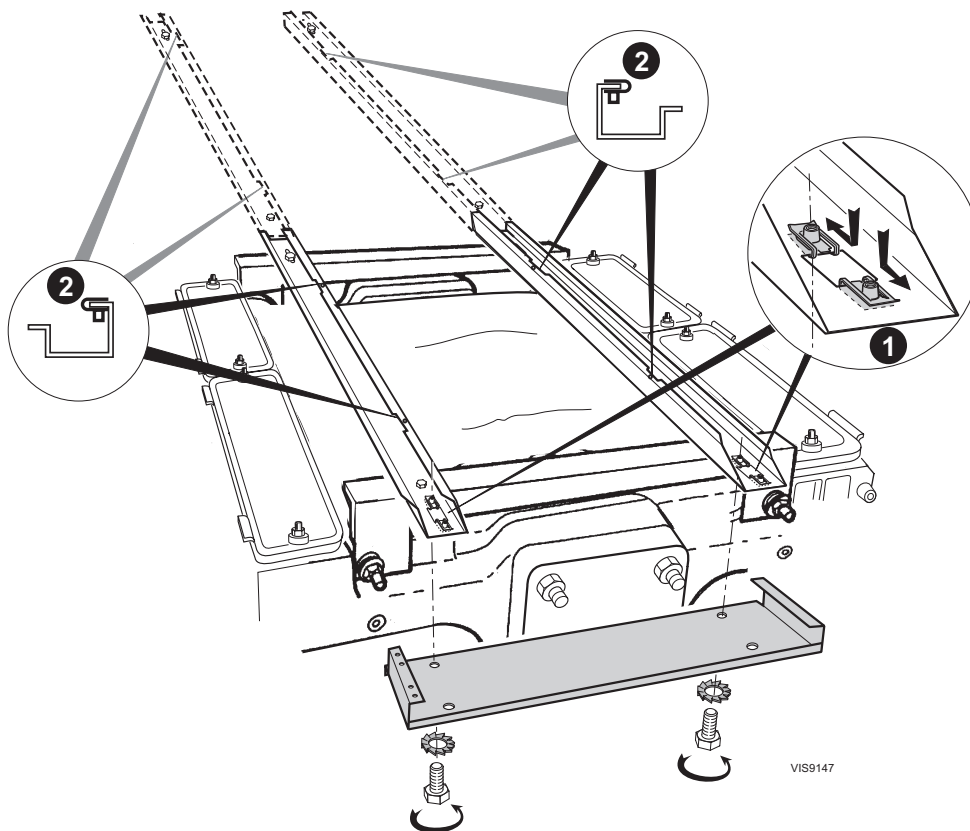

- Fit the four "Rapid nuts" on the front of the cable channels (1).
- Fit the Rapid nuts in the slot (2):
  - 4 Rapid nuts for 7-17 sections,
  - 8 Rapid nuts for 18-25 sections.
- Fix the control panel bracket (package IG84 or IG85) underneath the two cable channels by means of two M8 x 16 screws and two serrated washers.

### 56 INSTALLING THE CONTROL PANEL

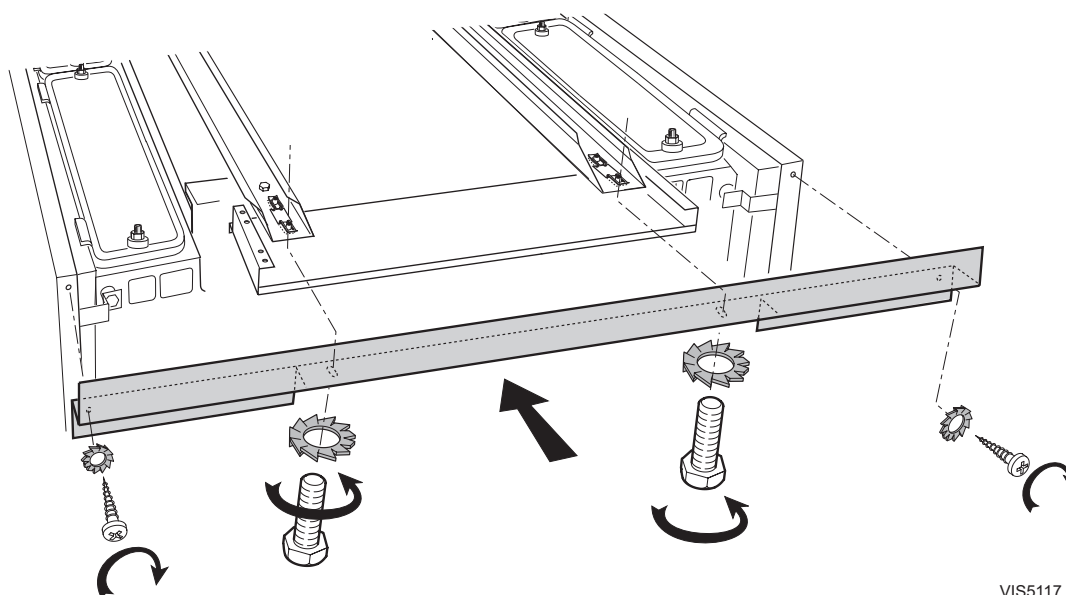

- Place the front crosspiece underneath the control panel bracket and fasten from below with M8 x 30 screws and serrated washers.
- Fix to the side panels with two  $\text{Ø } 3.94 \times 12.7$  tapping screws and serrated washers

## INSTALLATION

### 57 INSTALLING THE STANDARD CONTROL PANEL - Cont'd

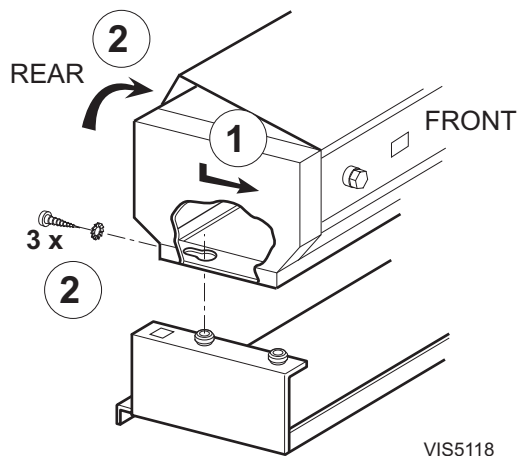

- Position the control panel on the rear studs (1).
- Open the control panel (3 screws at the back) (2).

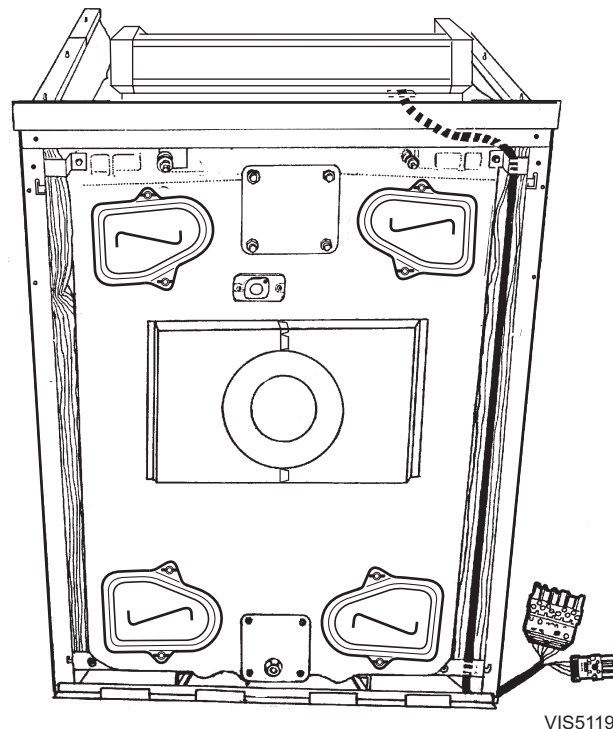

- Bring the burner cable behind the casing support and down to the burner between the side panel and insulating material.

- Fasten the control panel to the panel base with two  $\varnothing$  3.94 x 25 tapping screws and serrated washers (1).
- Carefully unroll the various bulbs and bring them out of the control panel through the opening designed for that purpose. Cut out the top insulating material and insert the bulbs in the boiler pocket and hold them in place using the spring (2).
- Fasten **rear cover H** (package **IG84** or **IG85**) to the control panel bracket using two EC CB 4 x 40 screws and serrated washers (3).
- Make the **electrical connections** to the two terminal blocks provided for this purpose inside of the control panel. See the "Electrical Connections" - Frame 64.
- Close the control panel.

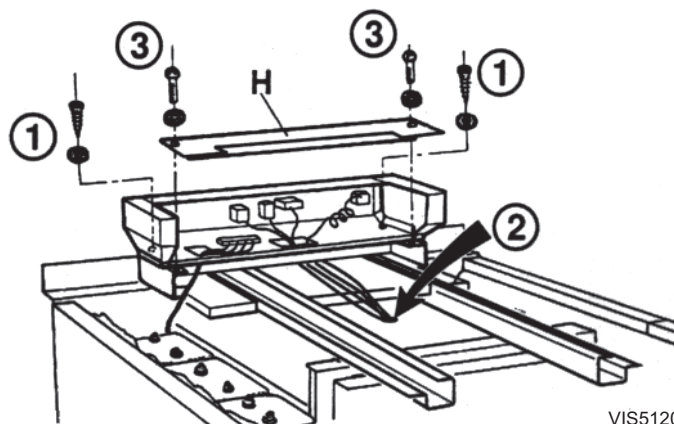

## INSTALLATION

### 58 ASSEMBLING THE FRONT PANELS

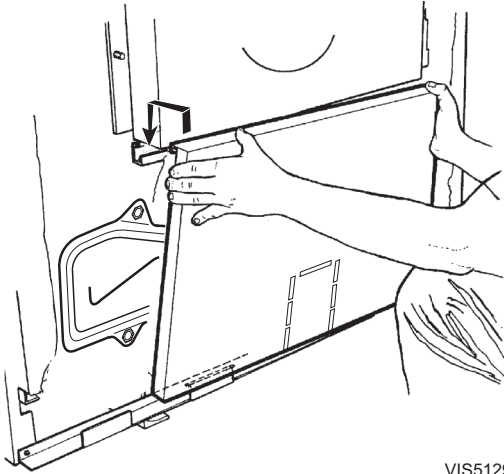

VIS5129

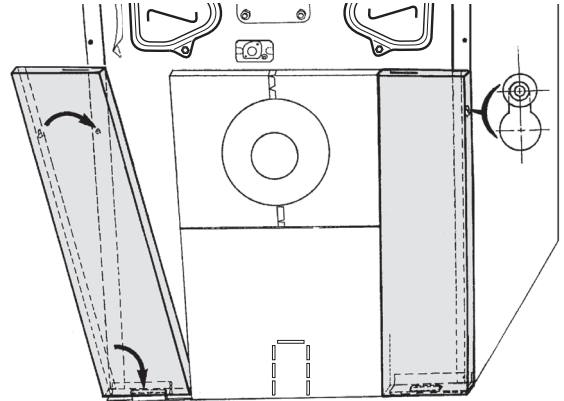

VIS5130

- Place the insulating material in the lower central front panel (black cloth facing outward).
- Fit **the lower central front panel** (package IG84 or IG85) onto the lower front crosspiece and fix it to the furnace door panel.
- Fit **the left and right-hand side front panels** (package IG84 or IG85) onto the lower front crosspiece and fit them onto the studs of the side panels.

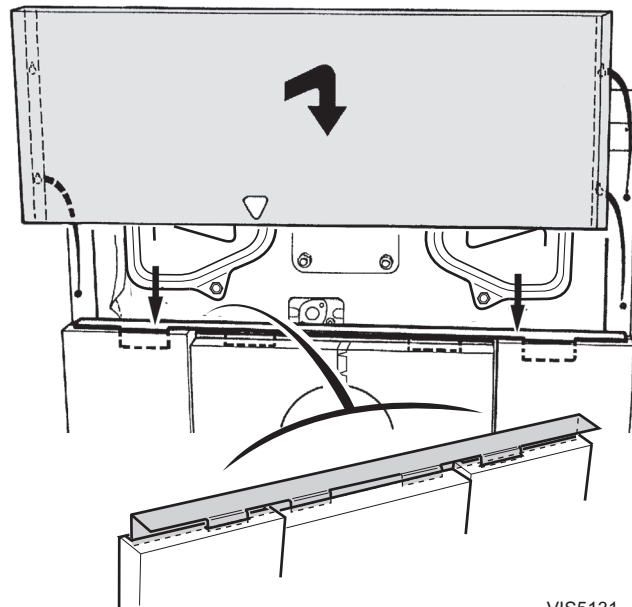

VIS5131

- Place **the retaining crosspiece** (package IG84 or IG85) on **the left and right-hand front panels**, taking care to place the two central tabs **behind** the furnace door panel.
- Fit **the upper front panel** (package IG84 or IG85) onto the **side panels** via the four studs.

# INSTALLATION

## 59 ASSEMBLING THE REAR PANELS

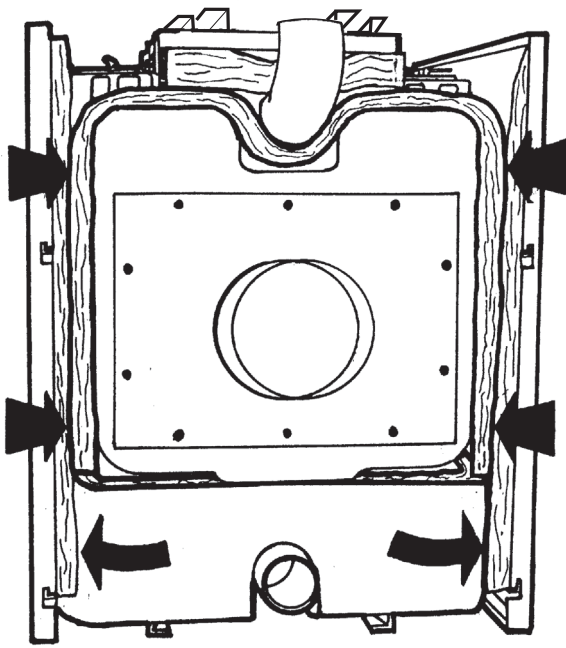

VIS5132

- Put in place the **insulation of the flue gas box and the lower rear insulating material** (package IG84 or IG85).

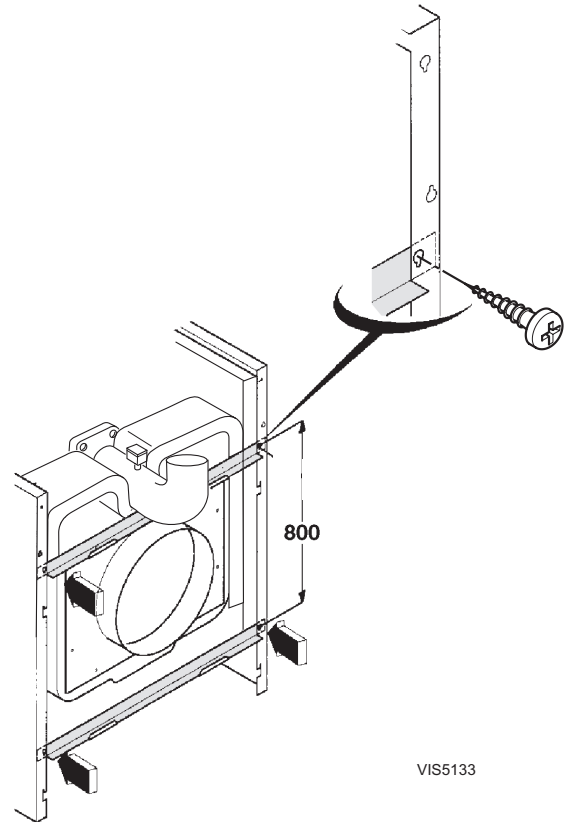

VIS5133

- Put in place the **two rear crosspieces** (package IG84 or IG85) behind the bend of the rear side panels and fasten each crosspiece to the side panels using two  $\varnothing 3.94 \times 12.7$  screws.

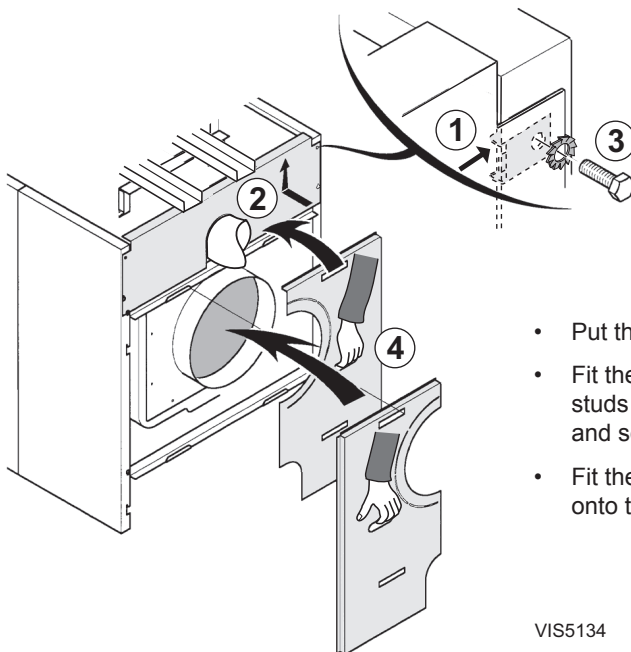

VIS5134

- Put the two clip-on nuts in place on the side panels (1).
- Fit the **upper rear panel** (package IG84 or IG85) onto the studs and push it up (2). Fasten with two M8 x 16 screws and serrated washers (3).
- Fit the **two lower rear panels** (package IG84 or IG85) onto the rear crosspieces (4).

# INSTALLATION

## 60 ASSEMBLING THE TOP PANELS

### Assembling the Central Plate for 14 - 17 Sections

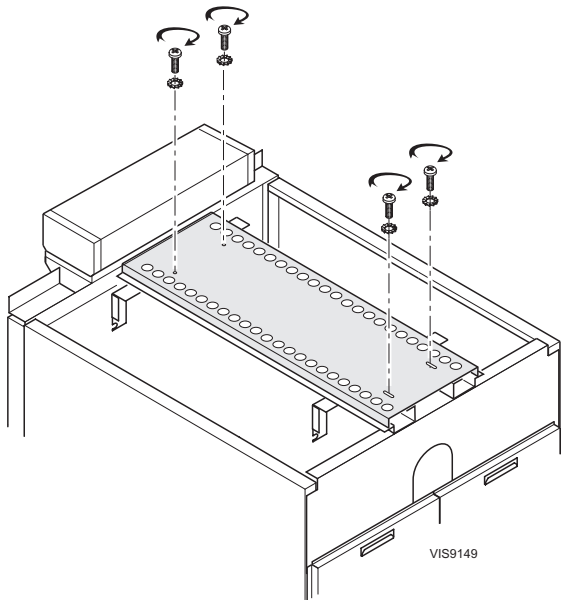

- Place the central plate on the cable channels with the round holes towards the front of the boiler.
- Fasten with M8 x 30 screws and serrated washers.

### Assembling the Central Plate for 18 - 25 sections

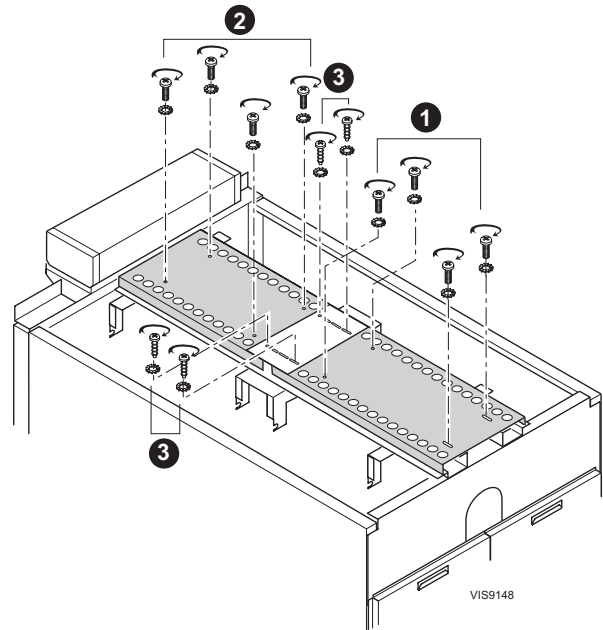

- Place the rear plate, which is **1200 mm long** (1).
- Fasten with four M8x30 screws and serrated washers.
- Place the front plate with the round holes towards the front of the boiler (2).
- Fasten with four M8 x 30 screws and serrated washers.
- Fasten the joining plate (3) with the round holes towards the front of the boiler with four tapping screws and serrated washers.

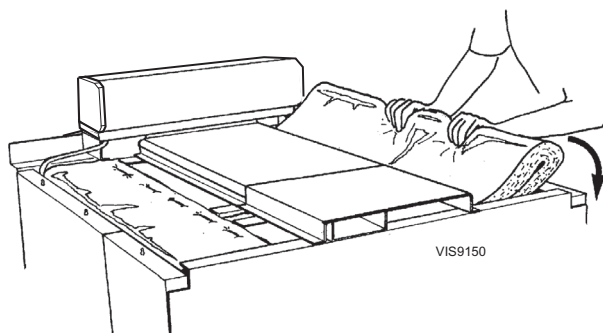

- Put in place **the cleanout cover insulating material** (packages **FA 30 - FA 41**):
  - GTS 14 - 17 : 2 pieces
  - GTS 18 - 25 : 4 pieces.



# INSTALLATION

## 61 ASSEMBLING THE TOP PANELS - Cont'd

- Place the **side covers** (package No's, see table) from the front to rear. They have the same lengths as the side panels.

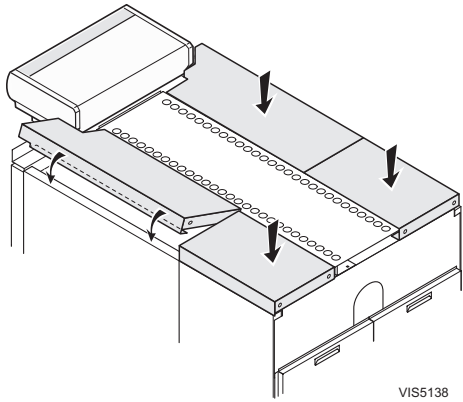

VIS5138

Type of Boiler	FRONT <span style="float: right;">→</span> REAR				
	Central and Side Covers (Length in mm)				
GTS 14	800	600	600		
GTS 15	940	600	600		
GTS 16	1050	600	600		
GTS 17	940	600	400	400	
GTS 18	1050	600	400	400	
GTS 19	940	600	600	400	
GTS 20	940	600	600	600	
GTS 21	1050	600	600	600	
GTS 22	940	600	600	400	400
GTS 23	1050	600	600	400	400
GTS 24	940	600	600	600	400
GTS 25	1050	600	600	600	400

400 mm long panel in Package FA10  
 600 mm long panel in Package FA11  
 800 mm long panel in Package MR3  
 940 mm long panel in Package MR4  
 1050 mm long panel in Package MR5

## 62 IDENTIFICATION PLATE

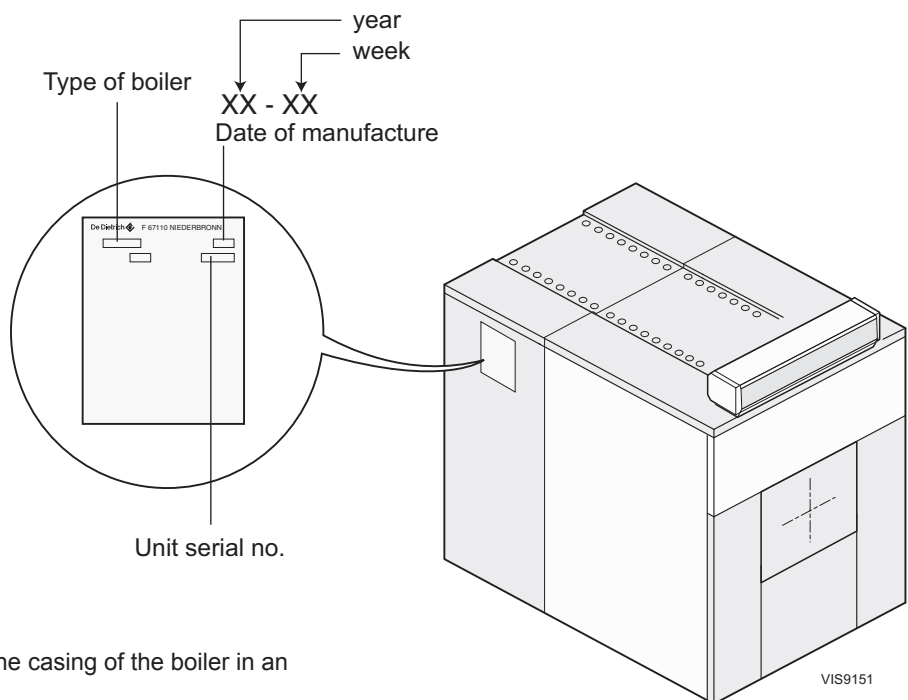

- Glue the identification plate on the casing of the boiler in an easily visible location.

VIS9151

# INSTALLATION

## 63 CONTROL PANEL (General)

Refer to Frame 69 for specific details of panel.

Electrical control panel, equipped with temperature control.

### The control panel carton contains:

Control panel complete with burner connection harness.

The control panel incorporates a boiler thermostat controller, a thermometer and a safety thermostat.

operating temperature. The other controls the high/low operation if a 2 stage burner is fitted.

**The safety thermostat** (with manual reset) - if the boiler temperature rises abnormally (110°C), the safety thermostat cuts off the burner electricity power supply.

**WARNING.** In this case, you must call your installer

**The boiler thermostats** - one controls the maximum boiler

## 64 ELECTRICAL CONNECTIONS

**WARNING.** The electrical connections must be made by a qualified professional. The electrical wiring has been carefully checked in the factory and the internal connections of the control panel must not be modified in any event.

The electrical connections should be made following the information shown on the electrical diagrams delivered with the unit and the directions given in the instructions.

The electrical connection must comply with standards in force. The equipment must be powered by a circuit containing a remote double-pole switch with opening  $\geq 3\text{mm}$ .

**WARNING.** The boiler must be earthed.

All connections must be made using the terminal blocks provided for this purpose at the back of the boiler control panel.

Connections cables are brought inside the boiler through cut-outs provided in the boiler back panel, which are large enough for use of commercially available conduit if required.

These cables are secured at the back of the control panel using cable clamps (cable clamps supplied in a separate pack) that are to be installed on the sheet metal.

## 65 BASIC CONNECTIONS

- To gain access to the connection strip, unscrew the three screws on the rear of the control panel and open the panel.
- Pass the connecting cables to the control panel through the two cut-outs in the rear panel of the boiler and route them to the front via the cable channels.
- Pass the cables into the control panel through the rectangular openings in the front top panel.
- Secure the cables to the base of the control panel with the cable clamps.
- Connect the main supply to terminals 1, 2 and 3 of the connecting strip as shown. (See also Frame 66)

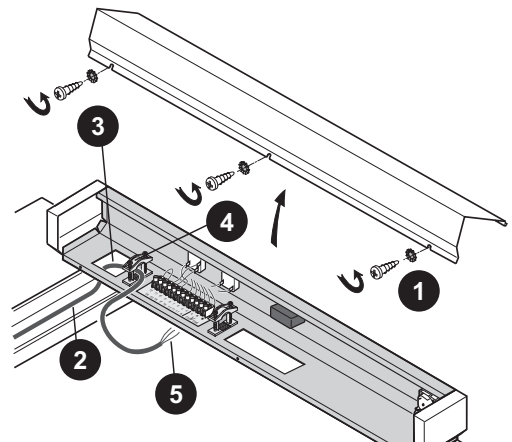

## 66 CONNECTING OPTIONAL FEATURES

### Flow Switch / Optional Safety Devices

If a flow switch or other safety control is to be included in the system, connect the device(s) in series in the safety circuit, (i.e. between terminal 5 of the connecting strip and burner terminal L1).

### Burner Alarm Indicator

If an alarm indicator is to be included it should be connected across terminal 12 (live) and terminal 4 (neutral).

### Safety Thermostat Alarm Indicator System

- The unused insulated terminal on the safety thermostat may be used to connect an alarm signal. (This terminal becomes live if the safety thermostat trips.)
- Remove the insulation and connect the live wire from the alarm indicator to the unused terminal using a suitable spade connector and the neutral to terminal 4.

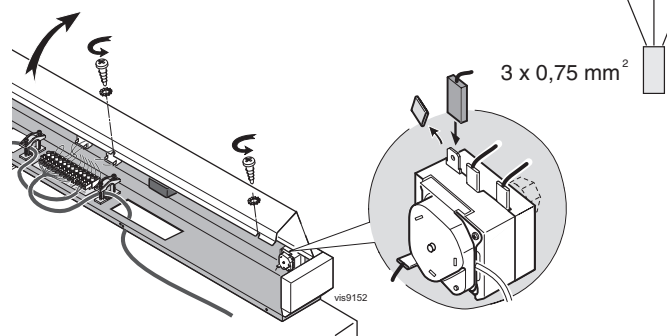
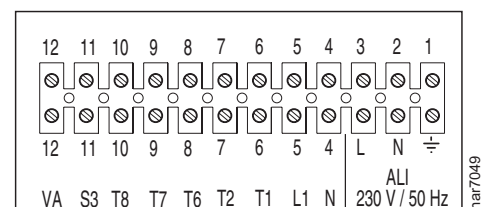

## 67 BURNER WIRING HARNESS

### Burner Cable

The control panel is supplied with a burner power supply cable, with one 7 and one 4-pin European plugs on one end and a terminal block with male connecting terminals on the other end.

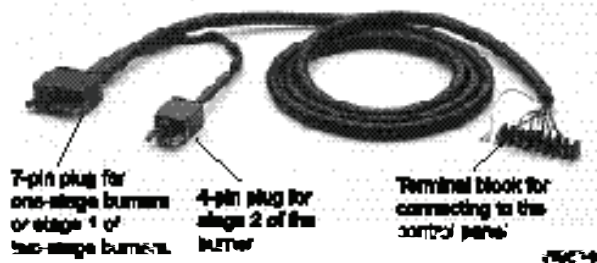

### Control Panel Connections

Connect the terminal block with the male connecting terminals to terminals 4-12 in the control panel.

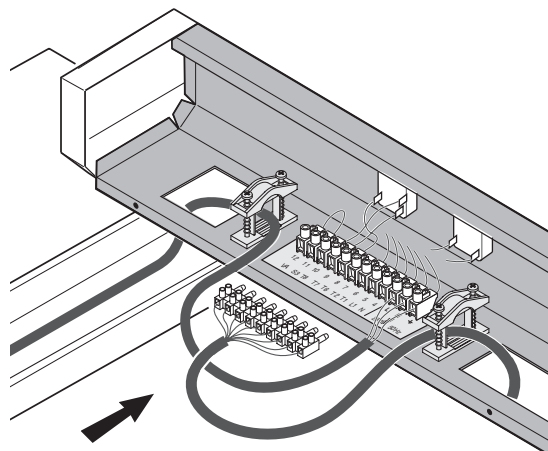

har7058

### Burner Connections without Plug-in Connectors

In this case, the connectors supplied with the burner cable must be rewired.

The diagram shows the wire numbers and terminals of the burner connectors.

The table below specifies the way in which the cables are to be connected to the burner control box.

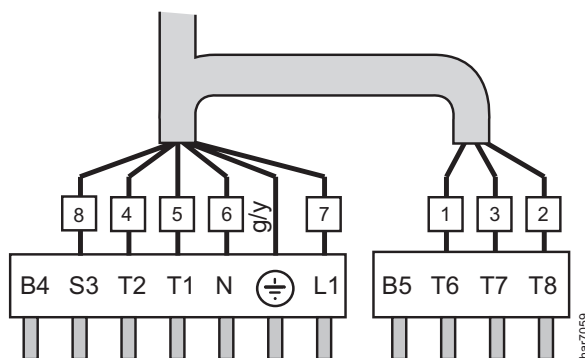

har7059

Burner Connector Terminal No.	Wire No.	From	Connection to the Burner Control Box
L1	7	Permanent Live supply from the safety thermostat	Burner main supply
⊥	g/y	Earth connection	Earth connection
N	6	Neutral taken after On/Off Switch	Neutral terminal
T1/T2	5/4	Volt free contact of the stage 1 boiler thermostat	Insert the control circuit of boiler stage 1
S3	8	Burner alarm indicator	Alarm output (live)
T6	1	Stage 2 boiler thermostat input	Insert in the control circuit of burner stage 2
T7	3	Stage 2 "boiler off" thermostat output	Connect only if the burner is of the modulating type
T8	2	Stage 2 "boiler on" thermostat output	Insert in the control circuit of burner stage 2

### Note.

If the electrical characteristics of the burner exceed the following values:

- start up current > 16 A or
- $P > 450 \text{ W}$  (or 1/2 cont. hp. motor), or
- $I > 2A \cos \varphi = 0,7$

The burner controls circuit must use a relay.

INSTALLATION

68 WIRING DIAGRAM

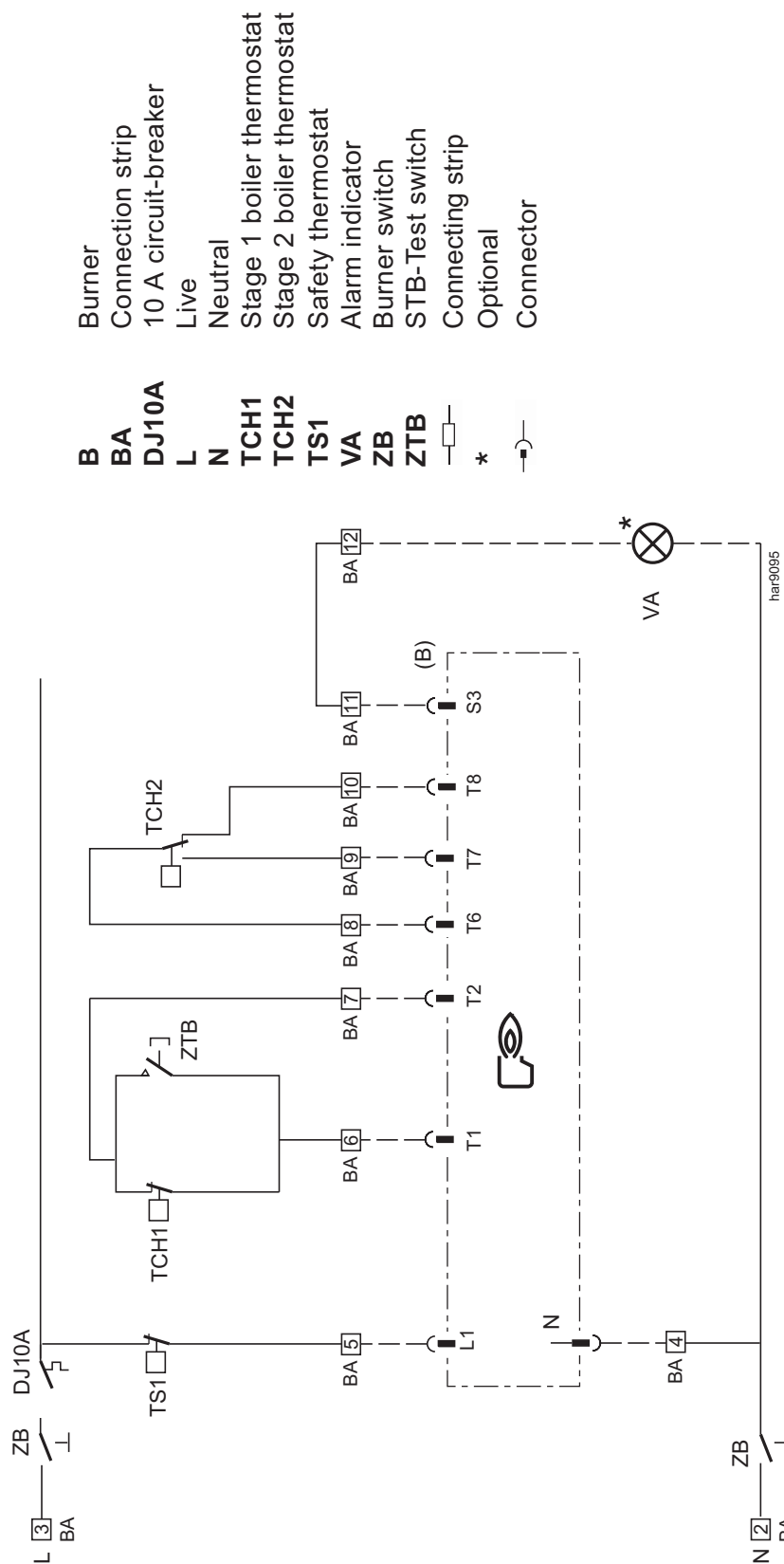

- B Burner
- BA Connection strip
- DJ10A 10 A circuit-breaker
- L Live
- N Neutral
- TCH1 Stage 1 boiler thermostat
- TCH2 Stage 2 boiler thermostat
- TS1 Safety thermostat
- VA Alarm indicator
- ZB Burner switch
- ZTB STB-Test switch
- \* Connecting strip
- Optional
- Connector

har9095

# INSTALLATION

## 69 COMMISSIONING

**IMPORTANT.** Domestic hot water circuits (if they exist) and heating circuits must have been filled and bled, and leak tightness tests must have been carried out on them, in accordance with the instructions for the domestic hot water calorifier (if existing) and boiler.

boiler.

- the instructions delivered with the burner.
- the instructions delivered with the domestic hot water calorifier, (if existing).

Refer to the following instructions and Frame 72 to start up the

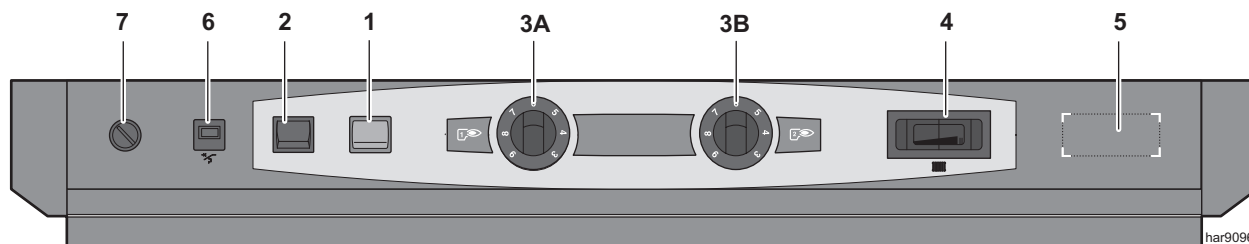

- |  |   |
|--|---|
| <p><b>1. Boiler ON/OFF switch.</b><br/>Position ① .....ON Position ○ .....OFF</p> <p><b>2. TEST STB:</b><br/>When held in the pressed (momentary use) position it tests the safety thermostat.</p> <p><b>Note.</b> If two stage burner control fitted operation will continue on 1st stage after 2nd stage cut-off.</p> <p><b>3. Boiler Thermostats:</b><br/>Adjustment range 30-90°C<br/>For ON/OFF burners use 1st stage thermostat only.<br/>For two stage burners set 2nd stage 5°C below 1st stage setting.</p> <p><b>4. Boiler Thermometer</b></p> | <p><b>5. Location for Flue Gas Thermometer (Optional)</b></p> <p><b>6. Timed Circuit Breaker:</b><br/>10A with delayed action and manual reset.</p> <p><b>7. Safety Thermostat:</b><br/>Set at 110°C. Manual reset.</p> |
|--|---|

## 70 BOILER THERMOSTAT (Maximum Setting Adjustment)

The boiler thermostats maximum setting are factory set at 75°C. The fixed stop controlling the maximum setting is adjustable as follows:

1. Carefully remove the control knob.
2. Pull out the pin from the back of the knob.
3. Relocate in the desired position, (maximum 90°C).  
(The setting numbers 3-9 are approximately scaled to represent 30-90°C)
4. Carefully replace the knob ensuring that the new pin position is at the correct side of the stop.
5. Rotate the knob to the new desired maximum position to check correct setting.

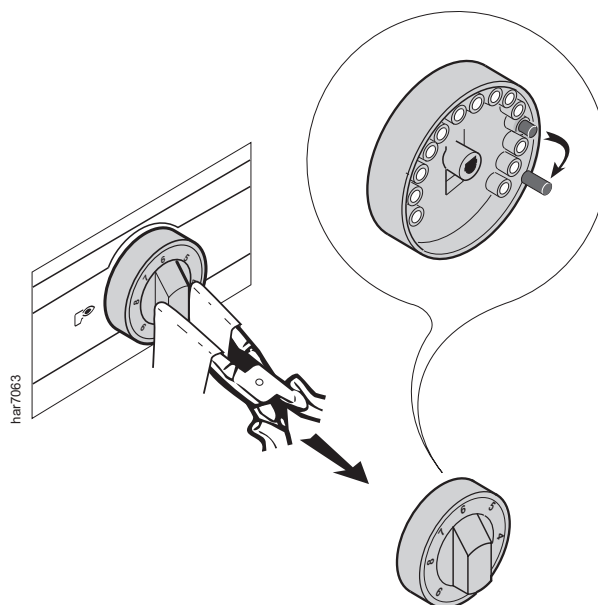

# INSTALLATION

## 71 COMMISSIONING AND TESTING

### A. ELECTRICAL INSTALLATION

1. Checks to ensure electrical safety should be carried out by a competent person.
2. ALWAYS carry out the preliminary electrical system checks, i.e. earth continuity, polarity, resistance to earth and short circuit, using a suitable meter.

1. The whole of the gas installation, including the meter, should be inspected and tested for soundness and then purged in accordance with the recommendations of the relevant standards listed on page 4.

### B. FOR GAS INSTALLATION

**WARNING.** Whilst effecting the required gas soundness test and purging air from the gas installation, open all windows and doors, extinguish naked lights and DO NOT SMOKE.

## 72 INITIAL LIGHTING

1. Check that the system has been filled and the boiler is not air locked - air in the boiler could damage the heat exchanger.
2. Check that all the drain cocks are closed and any valves in the flow and return are open.
3. Check that the GAS SERVICE COCK IS ON.
4. Unscrew the safety thermostat (overheat) reset button cap (7) and press the reset button.
5. Set the boiler thermostats (3) to maximum.
6. Switch the electricity supply ON and check that all the external controls are calling for heat. Set the main boiler switch (1) to ON (⓪).
7. The burner will commence the ignition sequence. If the burner has failed to light then it will lock out. Press the reset button to restart the ignition sequence.
8. Operate the boiler for 20 minutes and for gas fired boilers check the gas rate (Table 1).
9. Refer to the burner instructions for specific operating features.
10. Set the boiler thermostats (3) to the appropriate settings ensuring the second stage is 5°C lower than the first stage if a 2 stage burner is fitted.

## 73 GENERAL CHECKS

Make the following checks for correct operation.

1. The correct operations of ANY secondary system controls should be proved. Operate each control separately and check that the main burner or circulating pump, as the case may be responds.
2. Water circulation system;
  - a. With the system HOT examine all water connections for soundness.
  - b. With the system still HOT, turn off the gas or oil burner, water and electricity supplies to the boiler and drain down to complete the flushing process.
  - c. Refill and vent the system, clear all air locks and again check for water soundness.
  - d. Balance the system.
3. Finally set the controls to the User's requirements.

### Note.

*We advise never to set the boiler thermostat below position 4 (approx. 40°C) in order to avoid the risk of combustion products condensing on the walls of the boiler.*

## 74 HANDING OVER

### ROUTINE OPERATION

Describe the function of the boiler and system controls and show how they are adjusted and used.

Hand these Installation and Servicing Instructions, User's Instructions and Log book to the customer and request that they be kept in a safe place for ready reference.

**IMPORTANT.** Point out the owner that the boiler must have

regular maintenance and cleaning, at least annually, in order to ensure reliable and efficient operation. Regular attention will also prolong the life of the boiler and should preferably be performed at the end of the heating season.

Recommend that a contract for this work should be made with the regional gas authority or a Gas Safe registered heating installer for gas fired boilers.

# INSTALLATION

## 75 FUEL-OIL OR GAS CONNECTIONS

Refer to the instructions supplied with the burner



### IMPORTANT

The operations described below shall only be performed with the boiler and **power supply off**.

## 76 CLEANING

The boiler will only operate efficiently if the exchange surfaces are kept clean.

The boiler should be swept as an when required, **at least along with the chimney, once a year** or more, depending upon applicable regulations and specific needs.

- Turn off the power to the boiler.
- Remove the upper front panel (1).
- Remove the retaining upper front crosspiece (2) and then the lower left and right-hand front panels (3).
- Remove the lower front panel (4).

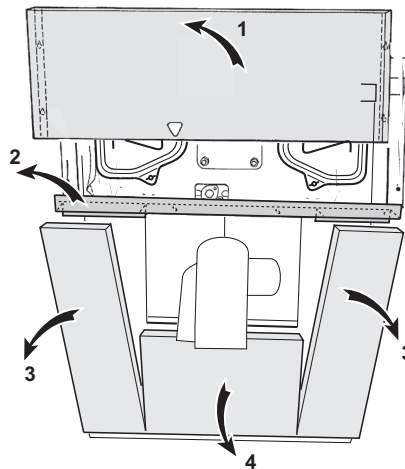

VIS5166

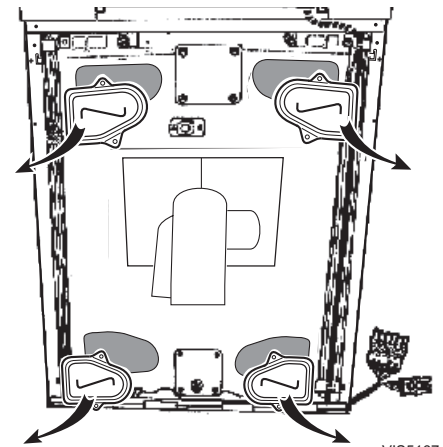

VIS5167

- Unfasten the wing nuts and remove the four sweeping doors.

## 77 CLEANING THE FLUEWAYS AND VERTICAL PLATES

- Remove the baffle plates from the upper flue ways.
- Carefully sweep the four flue ways with the brush supplied for that purpose.
- Brush the baffle plates as well.
- If possible, use a vacuum cleaner.

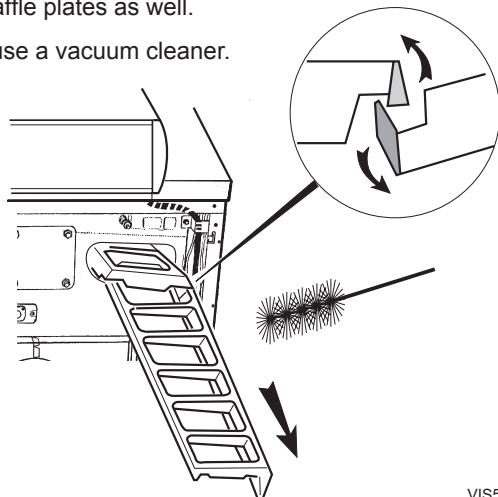

VIS5168

- Remove the left and right-hand casing covers.
- Remove the top insulating material.

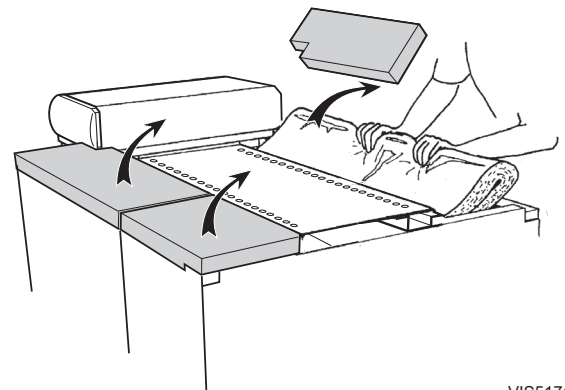

VIS5171

## SERVICING

### 78 CLEANING THE FLUEWAYS AND VERTICAL PLATES - Cont'd

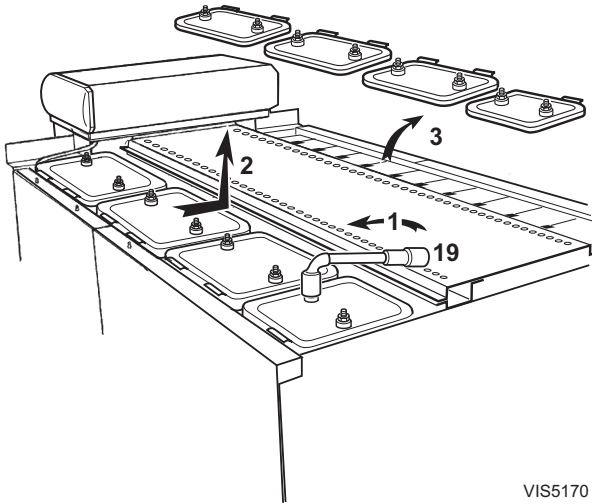

VIS5170

- Unfasten the nuts up to the stop.
- Push in the handles of the cleanout covers.
- Remove the cleanout covers.

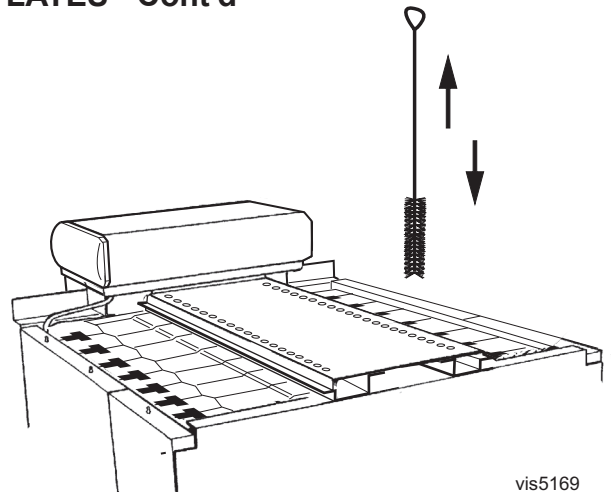

vis5169

- Brush the vertical plates.
- Replace the cleanout covers, insulating material and casing covers by reversing the procedure above.

**Note: chemical sweeping is recommended for such boilers.**

- Put the baffle plates back in place.  
Interlock them with each other while fitting them into the flue ways.
- Replace the upper cleanout doors.

### 79 CLEANING THE FURNACE

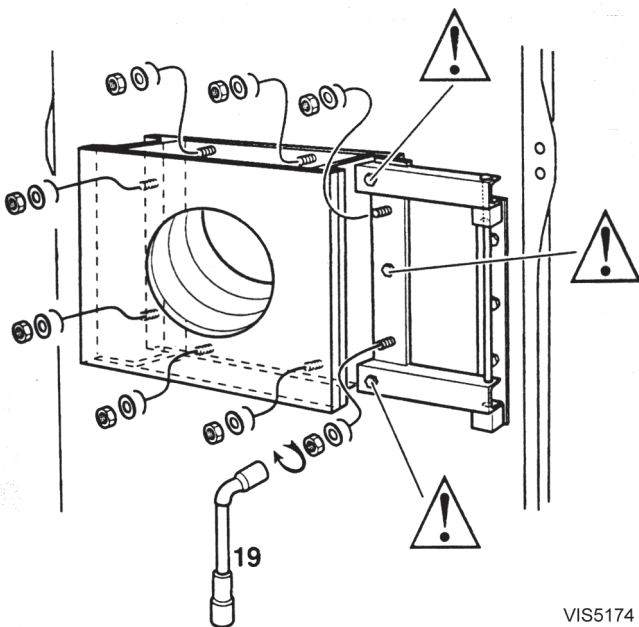

VIS5174

- Unscrew the eight closing nuts and open the furnace door

**These screws must not be unfastened in any event.**

⚠ Brush out the inside of the furnace.

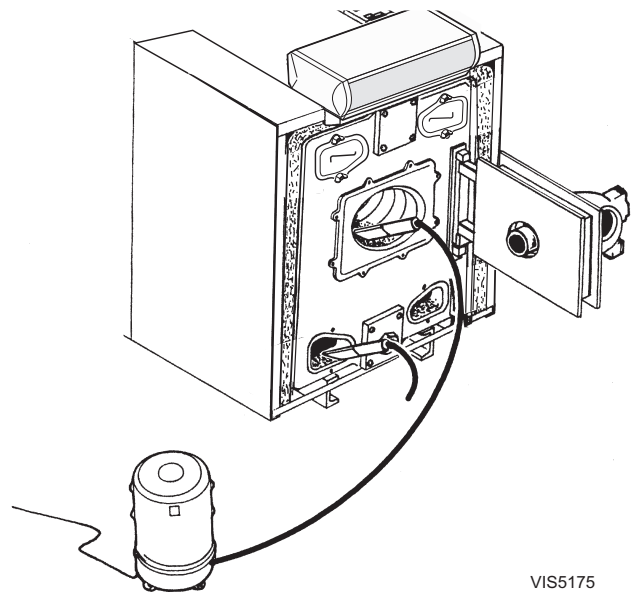

VIS5175

- Clean the soot accumulated in the furnace and lower flue ways with a vacuum cleaner.
- Replace the lower sweeping doors.
- Replace the front casing panels by reversing the removal procedure.



## 80 CLEANING THE SMOKEHOOD

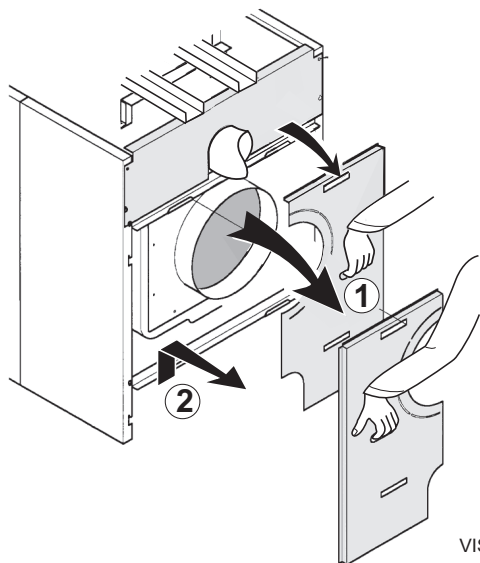

VIS5176

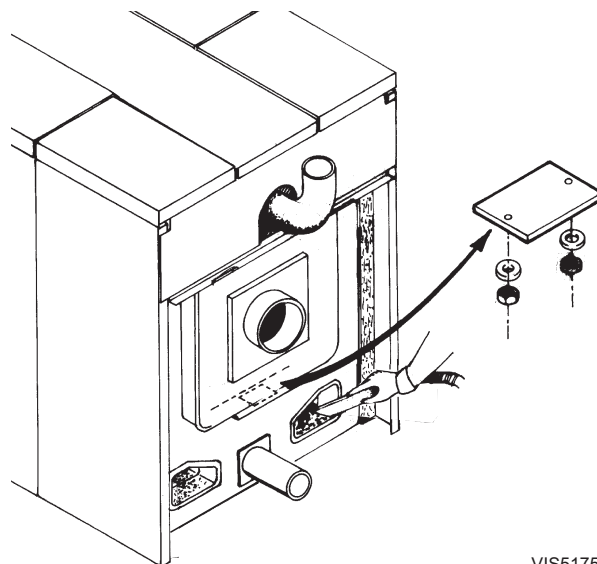

VIS5175

- Remove the lower rear panels.
- Remove the lower rear crosspiece.
- Remove the lower insulating material on the rear.
- Unfasten the wing nuts and remove the lower left and right-hand cleanout doors.
- Remove any soot deposit with a scraper or a vacuum cleaner.
- Open the lower cleanout cover of the flue gas box (two M10 nuts + washers).
- Remove the soot.
- Replace the cleanout cover and doors.
- Replace the lower insulating material, the crosspiece and panels by reversing the removal procedure.

## 81 GENERAL CLEANING

### CLEANING THE CASING MATERIAL

Use a soapy solution and a sponge only. Rinse with clean water and dry with chamois leather or a soft cloth.

### PRECAUTIONS REQUIRED IN THE CASE OF LONG BOILER STOPS (one or several years)

The boiler and the chimney must be swept carefully. Close all the doors of the boiler to prevent air from circulating inside the boiler.

We advise removing the pipe which connects the boiler to the chimney and to close off the nozzle with a cover.

### PRECAUTIONS REQUIRED IF THE HEATING IS STOPPED WHEN THERE IS A RISK OF FREEZING

We recommend the use of a correctly dosed antifreeze agent to prevent to the heating circuit from freezing. If this cannot be done, drain the system completely.

## 82 BURNER MAINTENANCE

Refer to the instructions supplied with the burner.

## 83 SYSTEM MAINTENANCE

### WATER LEVEL

Regularly check the level of water in the system and top up if required, taking care that cold water is not added suddenly into the boiler when it is hot.

This operation should be required only a few times in each heating season, with very low quantities of water. Otherwise, look for the leak and repair it.

### DRAINING

We advise you against draining the system unless it is absolutely necessary.

## NOTES

---

## NOTES

---

### **Technical Training**

The Ideal Technical Training Centre offers a series of first class training courses for domestic, commercial and industrial heating installers, engineers and system specifiers.  
For details of courses please ring:..... 01482 498432



Ideal Boilers Ltd. pursues a policy of continuing improvement in the design and performance of its products.  
The right is therefore reserved to vary specification without notice.

Ideal is a trademark of Ideal Boilers.  
Registered Office  
Ideal Boilers Ltd., PO Box 103, National Avenue, Kingston Upon Hull, HU5 4JN  
Tel 01482 492251 Fax 01482 448858  
Registration No. London 322 137

Ideal Technical Helpline: 01482 498376  
[www.idealcommercialboilers.com](http://www.idealcommercialboilers.com)