

GRUNDFOS UPML PUMP KIT



Low energy
consumption



Compact size



Low flow noise



High
efficiency



Cascade
compatible

Features & specification

For Evomax 2 and Imax Xtra 2 Cascades.

TECHNICAL SPECIFICATION

UIN	222659
CONNECTIONS	G 1 ½ " threaded connection
SYSTEM PRESSURE	Max. 1.0 MPa (10 bar)
MAXIMUM INLET PRESSURE	0.05 MPa (0.5 bar) at 95°C liquid temperature
LIQUID PRESSURE	-10°C to +95°C (TF 95)
MOTOR PROTECTION	Overload protection
NET WEIGHT	2.5kg
ENCLOSURE CLASS	IPX2D
INSULATION CLASS	H
EQUIPMENT CLASS	I
APPROVAL AND MARKING	VDE, CE
QUANTITY NEEDED	1 per boiler on Cascade

Compatible with PWM speed control for use with Evomax 2 boilers.

Supplied with:

- 0-10V/PWM wiring harness
- 2 x washers

PERFORMANCE OVERVIEW

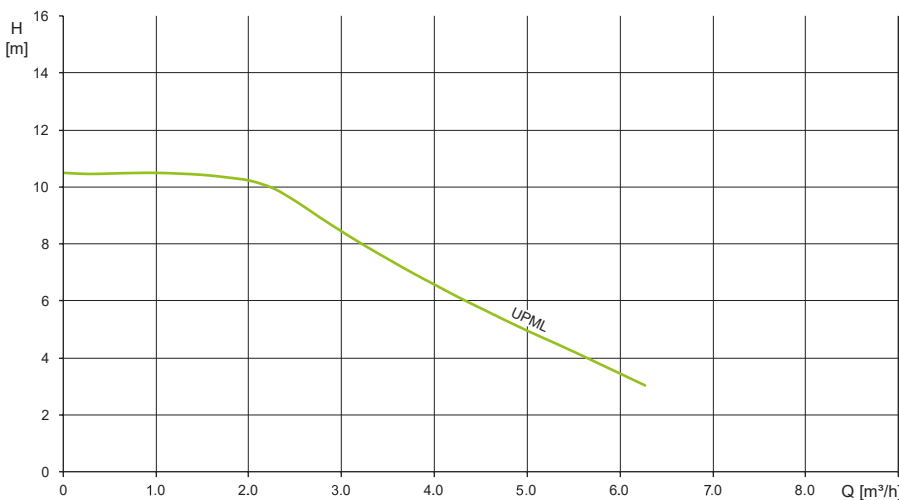

DIMENSIONS & CLEARANCES

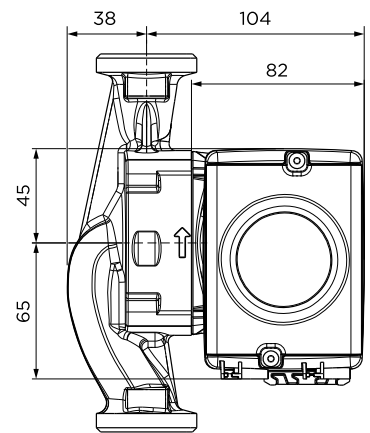
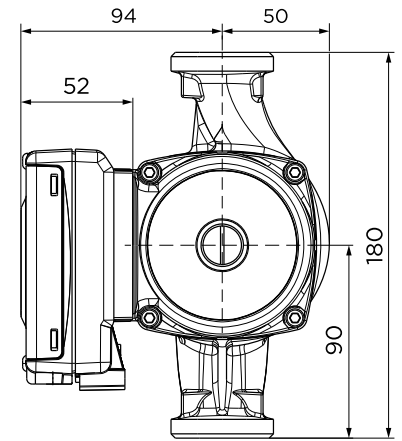

CONTROL BOX POSITIONS

