

LOGIC HIU

HEAT INTERFACE UNIT - 50 INDIRECT

2 YEAR WARRANTY

The Logic heat interface unit is the latest 'intelligent' range of HIU from Ideal. The Logic HIU is the complete solution for instantaneous hot water production and space heating control.

This is an indirect wall mounted HIU, providing 50 kW instantaneous priority DHW and 15 kW modulated CH. This can be converted to under floor heating including inbuilt safety thermostat capability.



FEATURES & BENEFITS

- Twin plate design hydraulically separates both domestic and space heating from the central primary supply
- Internal electronic control unit with LCD display
- The standard unit can be set to hold a stable heating flow temperature, to suit the installation (radiators, UFH for example), but crucially, can also be set to vary the heating flow temperature automatically depending on the temperature of the heating return water
- Automatically compensates for changes due to external influences, such as outside temperature etc. thereby ensuring that the unit and the system operate at maximum efficiency
- Pump bypass protection, in case of complete radiator TRV shutdown
- Compact and lightweight
- Fully insulated EPP front cover
- Convertible to underfloor heating
- Configurable hot water priority
- Pressure independent control valve
- Ability to pre-heating of the DHW exchanger

DIMENSIONS & CLEARANCES

CONNECTION	A	B	C
Thread	G $\frac{3}{4}$ "	G $\frac{1}{2}$ "	G1"

F	Depth inc. Cover	kg
630mm	265mm	19

* After shut-off valves are installed the connections become a female 3/4".

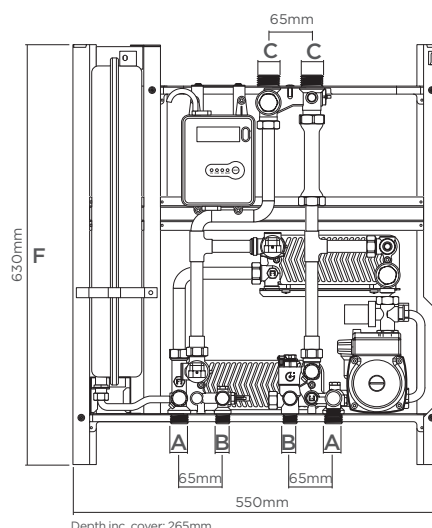

LOGIC HIU - 50 INDIRECT

TECHNICAL SPECIFICATIONS

PRIMARY PERFORMANCE

Maximum working pressure:	16 bar - primary 3 bar - secondary
Maximum temperature	85°C
Max. Percentage of glycol	30%
Max. Recommended primary circuit flow rate	1.2 m ³ /h

HEATING

The temperature setting operates on the principle of set point regulation and can be fixed within application limits.

Heating Set Point	25 to 75°C
Nom. heating exchanger net output:	15 kW
Secondary circuit:	Maximum pressure rating 3 bar Maximum operating pressure 2.5 bar
Pump	UPS 15/60
Pump bypass setting	0.45 bar
Pressure switch	Opening 0.4 bar Closing 0.8 bar
Safety relief valve setting	3 bar
Safety thermostat	55°C ±3
Expansion vessel	7.5 litre
Under floor heating capability	Optional
Heating control circuit	VOLT FREE

DOMESTIC HOT WATER - DHW

INCLUDING OPTIONAL PRE HEAT FUNCTION

The DHW function takes priority over the heating function controlled by the DHW priority flow switch.

Set Point DHW temperature	42 to 60°C
Max. Domestic hot water pressure	10 bar
DHW circuit max. flow rate	18 l/m (0.3 l/s)
Min. flow rate to activate domestic flow sensor	2.7 l/m ±0.3
Max. Differential pressure on domestic water modulating valve	Δp 1.65 bar
Min. Differential pressure on domestic water modulating valve	Δp 0.35 bar
Nom. DHW heat exchanger net output	50 kW - Logic HIU 50 Indirect

ELECTRICAL

Power supply	230 V (ac) ±10% 50 Hz
Max. Power consumption	105 W
Protection class	IP 40
Actuator	Stepper 24 V
Probes	NTC 10 kΩ

CONSTRUCTION

Frame	RAL 9010 sprayed steel
Protective shell cover	EPP (Expanded polypropylene)
Components	Brass BS EN 12165 CW617N
Pipes	Stainless steel
Exchanger	Brazed stainless steel

INCLUDED AS STANDARD

Heat Interface Unit 50	✓
Primary ball valve set	✓
Domestic connection flow & return valve kit	✓
Filling loop connection kit valves	✓

ACCESSORIES

Flushing By-pass	✓
CF Echo II	✓
CF Ultramaxx V	✓

UIN	PRODUCT NAME	METERING OPTIONS
211094	Logic HIU Indirect 50	HIU only, meter not included
211347	Logic HIU Indirect 50	Factory fitted, CF Echo II Mbus 1
211351	Logic HIU Indirect 50	Factory fitted, CF Ultramaxx V Mbus PS

HYDRAULIC CHARACTERISTICS HEATING - SECONDARY SIDE

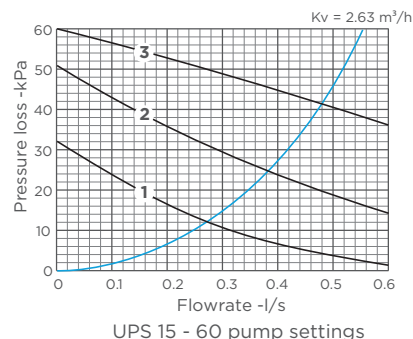

DOMESTIC HOT WATER OUTPUT

