

Maximiser SE 42 & SE 65

Installation & Servicing instructions

Wall Mounted, Fanned, Super Efficient Gas Boilers

Natural Gas Models Only

Maximiser SE 42 G.C. Appliance No. 41-349-85

Maximiser SE 65 G.C. Appliance No. 41-349-86

CAUTION. To avoid the possibility of injury during the installation, servicing or cleaning of this appliance care should be taken when handling edges of sheet steel components.

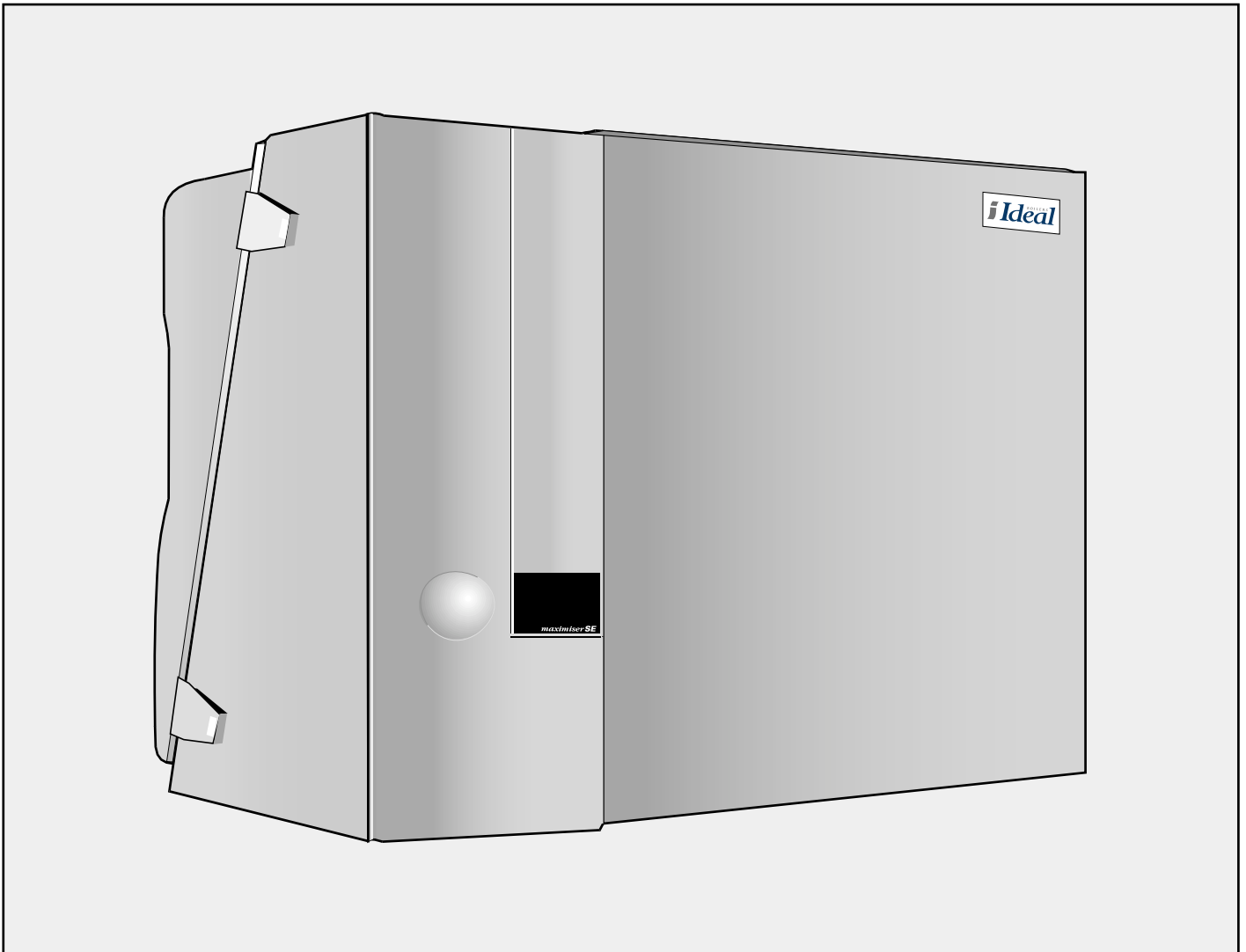

***i* Ideal** BOILERS

GENERAL

CONTENTS

Air Supply.....	8
Boiler Clearances.....	4
Boiler Exploded Diagram	7
Electrical Connections	18
Electrical Supply.....	6
Fault Finding	29
Flow Wiring Diagram	18
Flue Installation	9
Gas Safety (Installation & Use) Regulations, 1994 or 1996.....	2
Gas Supply	6
Health & Safety Document No 635.....	3
Installation	9
Mandatory Requirements.....	2
Pump	16
Servicing	23
Short List of Parts	34
Water Connections	4
Water and Systems	5
Wiring Diagrams.....	18

INTRODUCTION

Maximiser SE boilers are fully automatically controlled, wall mounted, low water content, balanced flue, fanned super efficient condensing gas boiler.

The Maximiser SE condensing boilers can be installed either on the wall or into a prefabricated floor mounted frame.

The boilers are suitable for use with a room sealed flue or open flued application.

Through a sophisticated control system combined with premix burner arrangement the boilers are capable of high operating efficiencies of 94% and low emissions.

The heat exchanger is manufactured from extruded aluminium finned tubes sealed into aluminium end plates.

Note. *These boilers cannot be used on systems which include gravity circulation.*

The boilers are suitable for connection to fully pumped, open vented or sealed water systems. Adequate arrangements for completely draining the system by provision of drain cocks MUST be provided in the installation pipework.

OPTIONAL EXTRA KITS

Roof Flue Kit 80/125 For vertical flue connection.

Roof Flue Kit 100/150 For vertical flue connection.

Pitched and flat roof tiles 125 & 150

For all vertical flue options'.

Vertical Twin Pipe Roof Kit 80/125

For vertical flue connection.

Vertical Twin Pipe Roof Kit 100/150

For vertical flue connection.

Horizontal Wall Flue Kit 80/125

For horizontal flue connection.

Horizontal Wall Flue Kit 100/150

For horizontal flue connection.

Sequence Control MBC 5 For control of more than one boiler.

Remote Indication alarm kit

For volt free contacts

2 Boiler Frame Kit

For double boiler application.

3 Boiler Frame Kit

For triple boiler application.

GAS SAFETY (INSTALLATION AND USE) REGULATIONS, 1994 OR 1996 (AS AMENDED)

It is law that **all** gas appliances are installed and serviced by a CORGI registered installer in accordance with the above regulations. Failure to install appliances correctly could lead to prosecution. It is in your own interest, and that of safety, to ensure the law is complied with.

The installation of the boiler MUST also be in accordance with the latest I.E.E Wiring Regulations, local building regulations, bye-laws of the local water authority, the building regulations and the Building Standards (Scotland) and any relevant requirements of the local authority.

Detailed recommendations are contained in the following British Standard Codes of Practice:

- BS. 6891 Low pressure installation pipes.
- BS. 6798 Installation of gas fired hot water boilers of rated input not exceeding 60 kW.
- BS. 5449 Forced circulation hot water systems.
- BS. 5546 Installation of gas hot water supplies for domestic purposes (2nd Family Gases)
- BS. 6644 Ventilation (for gas appliances of rated input exceeding 60 kW)
- BS. 5440:2 Ventilation (for gas appliances of rated input not exceeding 70 kW net.)
- BS. 5440:1 Flues (for gas appliances of rated input not exceeding 60 kW)
- BS. 4814 Specifications for expansion vessels

Health & Safety document no 635

The Electricity at Work Regulations, 1989

Table 1 - General Data

Model		SE 42	SE 65	
Boiler Input (Hs)	max	kW	45.0	62.7
		Btu/h	153,540	213,932
	min	kW	14.4	24.4
		Btu/h	49,133	83,253
Boiler Output (condensing) 50°/30°C	max	kW	43.3	60.0
		Btu/h	147,740	204,720
	min	kW	13.9	23.7
		Btu/h	47,427	80,864
Boiler Output (non-condensing) 80°/60°C	max	kW	40.0	55.1
		Btu/h	136,480	188,001
	min	kW	12.6	21.4
		Btu/h	42,991	73,017
*Gas Rate		m³/h	4.19	5.83
		ft³/h	147.97	205.98
Approx flue gas volume (non condensing) high rate		m³/s	0.021	0.029
		ft³/s	45	62.7
*Note: The gas rates quoted are for NATURAL GAS and assume a C.V. OF 38.7 (MJ/m³).				
Flow tapplings		mm	28	28
Return tapplings		mm	28	28
Maximum static water head		m	31	31
		ft	100	100
Maximum Pressure		bar	3	3
		psi	44	44
Gas inlet connection		R	1/2	1/2
		in. BSP	1/2	1/2
Pressure required at the boiler inlet for the rated input*		mbar	20	20
		in. w.g.	8	8
Electricity supply		230 V 50 Hz	230 V 50 Hz	
Nominal flue size / concentric		mm	80(100) / 125(150)	80(100) / 125(150)
Nominal flue size / twin pipe		mm	80 / 80	80 / 80
Condensate Drain Pipe		mm	32	32
NOx emissions		mg / kW / hr	33	36
		ppm	19	21
Water content		Lt	3.6	4.7
		gal	0.78	1.02
Weight		kg	72	75
		lb	159	165
IP Rating			IP 44	IP 44
Power Consumption		W	180	180
Seasonal efficiency *)		(SEDBUK) %	90.4	90.5

*)The value is used in the UK Government's Standard Assessment Procedure (SAP) for energy rating of dwellings. The test data from which it has been calculated have been certified by BG plc 0087.

The manufacturer's notes must NOT be taken, in any way, as overriding statutory obligations.

IMPORTANT. These appliances are CE certificated for safety and performance. It is, therefore, important that no external control devices, e.g. flue dampers, economisers etc., are directly connected to these appliances unless covered by these Installation and Servicing Instructions or as otherwise recommended by **Caradon Ideal Limited** in writing. If in doubt please enquire.

Any direct connection of a control device not approved by **Caradon Ideal Ltd.** could invalidate the certification and the normal appliance warranty. It could also infringe the Gas Safety Regulations and the above regulations.

Notes.

To obtain the gas consumption:-

- a.** For l/s divide the gross heat input (kW) by C.V. of the gas (MJ/m³)
- b.** For ft/h³ divide the gross heat input (Btu/h) by C.V. of the gas (Btu/ft³)

GENERAL

1 BOILER WATER CONNECTIONS

The boiler flow and return pipes are suitable for 28 mm compression fitting and are located at the bottom right hand side of the boiler.

Note.

This appliance is NOT suitable for use with a direct hot water cylinder.

LOCATION OF BOILER

The boiler must be installed on a flat and vertical wall, capable of adequately supporting the weight of the boiler and any ancillary equipment or on a 2 or 3 boiler frame supplied in kit form by Caradon Ideal Ltd.

The boiler may be fitted on a combustible wall and insulation between the wall and the boiler is not necessary, unless required by the local authority.

The boiler must not be fitted outside.

Timber Framed Buildings

If the boiler is to be fitted in a timber framed building it should be fitted in accordance with the Institute of Gas Engineers document IGE/UP/7.

2 BOILER CLEARANCES

The following minimum clearances must be maintained for operation and servicing.

- Front of boiler - 450 mm
- Sides of boiler - 50 mm
- Above boiler - dependant upon the system
- Below boiler - 100 mm

MOUNTING POSITION

Fig. 2.1

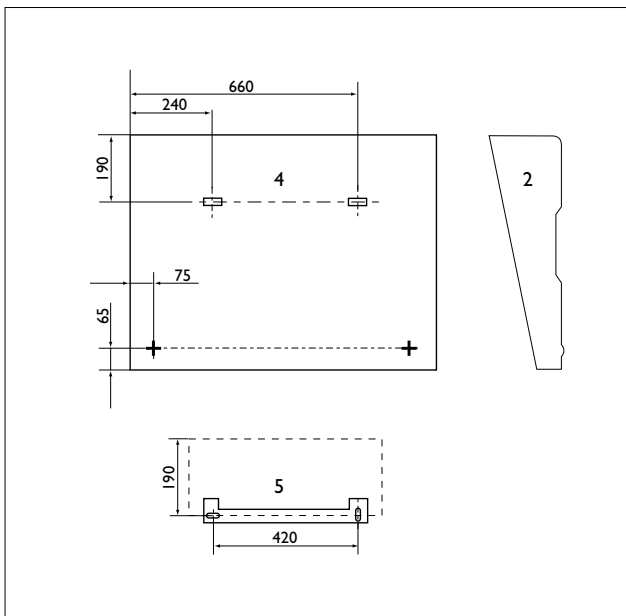

459137

- 1= Front view
- 2= Side view
- 3= Top view
- 4= Back view
- 5= Mounting bracket

BOILER DIMENSIONS

Fig. 2.2

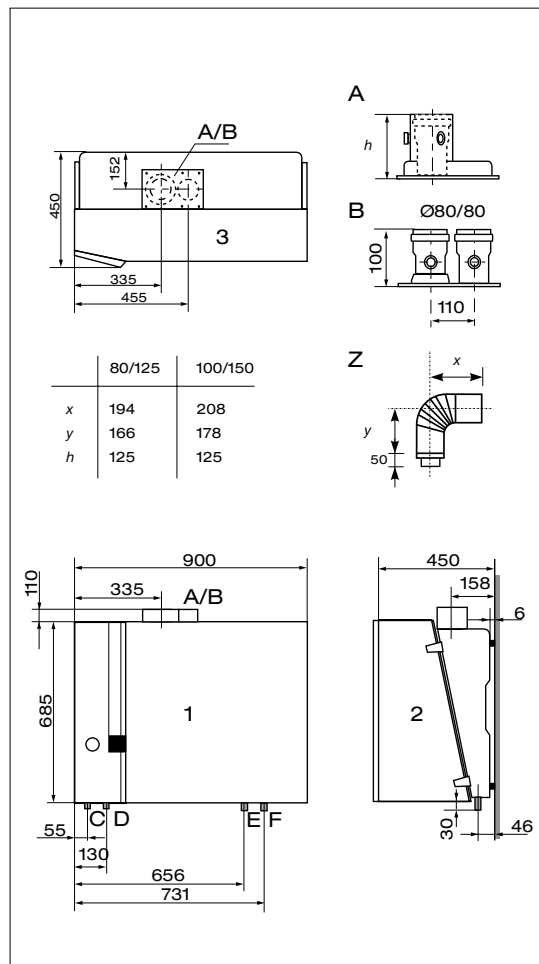

Key to diagram

459138

- A= Flue adapter concentric \varnothing 80/125
- B= Flue adapter twin pipe \varnothing 80/80
- C= Gas connection $\frac{1}{2}$ " B.S.P.
- D= Condensate drain \varnothing 32 mm
- E= Flow connection \varnothing 28 mm
- F= Return connection \varnothing 28 mm
- Z= 90° Elbow

3 OPEN VENT SYSTEM REQUIREMENTS

The system should be vented directly off the boiler flow pipe, as close to the boiler as possible. The cold feed entry should be inverted and **MUST** be positioned between the pump and the vent, and not more than 150 mm (6") away from the vent connection.

Note. Combined feed and vent pipes may also be fitted.

There should be a minimum height, 500 mm (20"), of open vent above the cistern water level. The vertical distance between the highest point of the system and the feed/expansion cistern water level **MUST** not be less than 3 m.

The vertical distance between the pump and feed/expansion cistern **MUST** comply with the pump manufacturer's minimum requirements, to avoid cavitation. Should these conditions not apply either lower the pump position or raise the cistern above the minimum requirement specified by **Caradon Ideal Ltd.** The isolation valves should be fitted as close to the pump as possible.

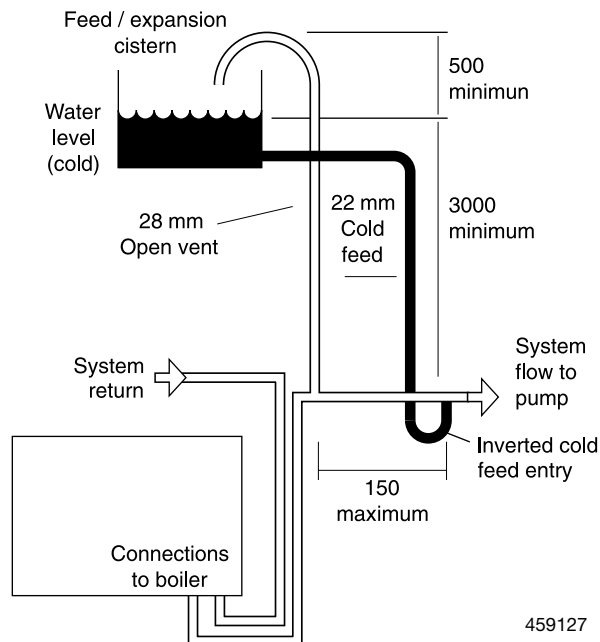

459127

4 SEALED SYSTEM REQUIREMENTS

Note. The method of filling, refilling, topping up or flushing sealed primary hot water circuit from the mains via a temporary hose connection is only allowed if acceptable to the local water authority.

1. General

- a. The installation must comply with the requirements of BS. 6798 and BS. 5449.
- b. The installation should be designed to work with flow temperatures of up to 90 °C and a temperature differential of 20 °C.
- c. All components of the system, including the heat exchanger of the indirect cylinder, must be suitable for a working pressure of 3 bar (45 Lbf/in²) and temperature of 110 °C. Care should be taken in making all connections so that the risk of leakage is minimised.

2. Safety Valve

A spring loaded safety valve complying with the relevant requirements of BS. 6759 must be fitted in the flow pipe as close to the boiler as possible and with no intervening valve or restriction. The valve should have the following features:

- a. A non-adjustable preset lift pressure not exceeding 3 bar (45 Lbf/in²).

3. Pressure Gauge

A pressure gauge covering at least the range 0-4 bar (0-60 Lbf/in²) must be fitted to the system. The gauge should be easily seen from the filling point and should preferably be connected at the same point as the expansion vessel.

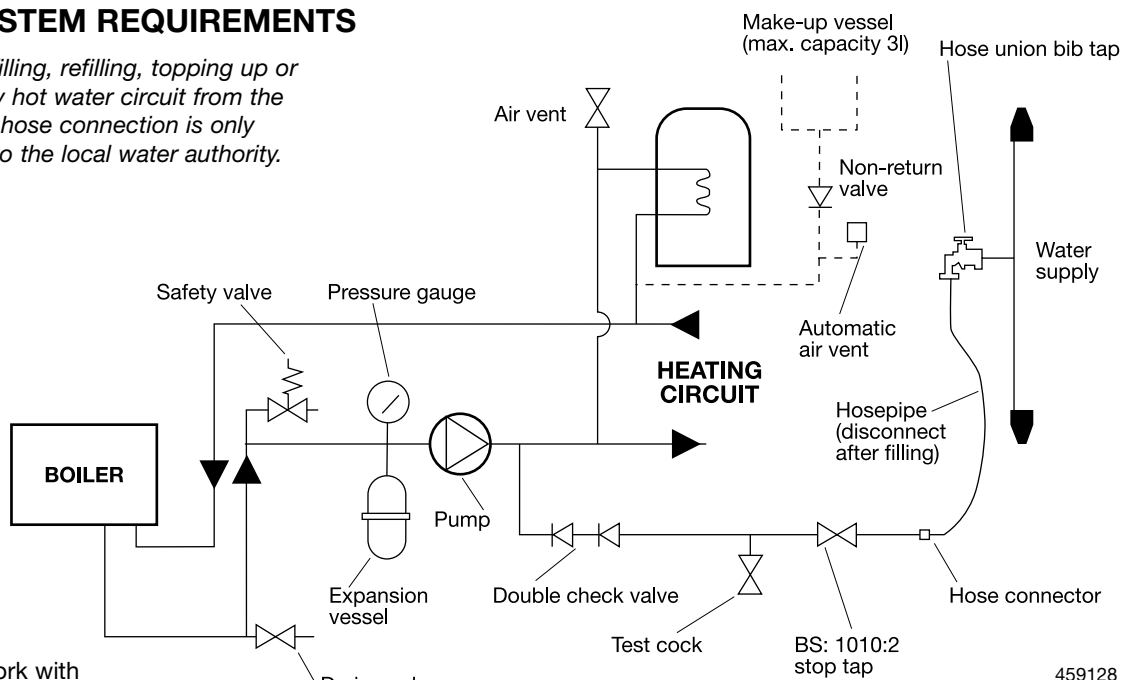

459128

- b. A manual testing device.
- c. Provision for connection of a discharge pipe. The valve or discharge pipe should be positioned so that the discharge of water or steam cannot create a hazard to the occupants of the premises or cause damage to electrical components and wiring.

GENERAL

5 WATER TREATMENT

The Maximiser boiler has an ALUMINIUM alloy heat exchanger

Corrosion will always occur within a heating/hot water system to a greater or lesser degree irrespective of water characteristics, unless the initial fill water from the mains is treated. For these reasons Caradon Ideal strongly recommends that when necessary the system be thoroughly cleaned prior to the use of a stable inhibitor which does not require continual topping up to combat the effects of hardness, salts, and corrosion on the heat exchanger and its associated systems.

The Ideal Maximiser SE boiler has an aluminium alloy heat exchanger. Therefore it is important that if water treatment is used it is suitable for the material of the heat exchanger. The ONLY water treatments approved are 'Fernox Copal' and 'Sentinel X 100' current suitability should be confirmed with the manufacturer direct.

**Betzdearborn Ltd.
Sentinel Division
Foundry Lane
Widnes, Cheshire
Tel 0151424 5351**

**Fernox
Fry Technology UK,
Tandem House, Marlowe Way,
Beddington Farm Road,
Croydon, CRO 4XS
Tel 0870 601 5000
Technical help 01799 550 811**

ANY OTHER treatment used will render the guarantee of Caradon Ideal for this product INVALID. The use of artificially softened water is not permitted.

WATER CIRCULATION SYSTEM

The boiler must NOT be used for direct hot water supply.

The central heating system should be in accordance with BS. 6798 and, in addition, for smallbore and microbore systems, BS. 5449.

WATER TREATMENT - see Frame 5

The hot water storage cylinder MUST be of the indirect type and should preferably be manufactured of copper.

Single feed, indirect cylinders are not recommended and MUST NOT be used on sealed systems.

The appliances are NOT suitable for gravity central heating nor are they suitable for the provision of gravity domestic hot water.

The hot water cylinder and ancillary pipework, not forming part of the useful heating surface, should be lagged to prevent heat loss and any possible freezing - particularly where pipes run through roof spaces and ventilated underfloor spaces.

The boiler must be vented.

Draining taps MUST be located in accessible positions, which permit the draining of the whole system - including the boiler and hot water storage vessel. They should be at least 1/2" BSP nominal size and be in accordance with BS. 2879.

ELECTRICAL SUPPLY

Wiring external to the appliance MUST be in accordance with the current I.E.E. (BS7671) Wiring Regulations and any local regulations which apply.

The point of connection to the mains should be readily accessible and adjacent to the boiler.

GAS SUPPLY

The local gas supplier should be consulted, at the installation planning stage, in order to establish the availability of an adequate supply of gas. An existing service pipe must NOT be used without prior consultation with the local gas supplier.

A gas meter can only be connected by the local gas supplier or by a registered CORGI engineer.

An existing meter should be checked, preferably by the gas supplier, to ensure that the meter is adequate to deal with the rate of gas supply required. A minimum working gas pressure of 20 mbar MUST be available at the boiler inlet.

Installation pipes MUST be fitted in accordance with BS. 6891. Pipework from the meter to the boiler MUST be of an adequate size.

Do not use pipes of smaller size than the boiler inlet gas connection.

The complete installation MUST be tested for gas soundness and purged as described in the above code.

CONDENSATE DRAIN - Refer to Frame 18

A condensate drain is provided on the boiler. This drain must be connected to a drainage point on site. All pipework and fittings in the condensate drainage system MUST be made of plastic - no other materials may be used.

IMPORTANT.
Any external runs must be insulated.

The drain outlet on the boiler is standard 32 mm overflow pipe.

6 BOILER ASSEMBLY - Exploded view

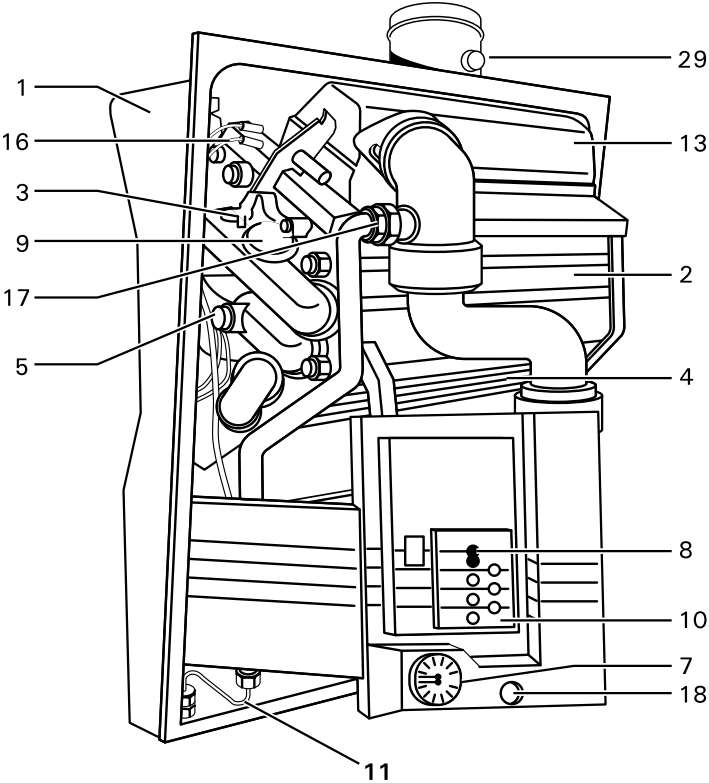

- 1. Frame
- 2. Heat exchanger
- 3. Ionisation probe
- 4. Lower access cover
- 5. Safety sensor
- 6. Sight glass
- 7. Temperature/pressure gauge
- 8. Display
- 9. Igniter
- 10. Control panel
- 11. Gas inlet pipe 1/2" to valve
- 12. Condensate drain 32 mm
- 13. Burner
- 14. Flow connection

459129

- 15. Return connection
- 16. Burner thermostat
- 17. Gas injector
- 18. Hand held diagnostic
- 19. Electrical terminal connection (options)
- 20. Fan
- 21. Air/gas connecting piece
- 22. Gas pipe from valve
- 23. Fan inlet pipe
- 24. Pump
- 25. Gas/air pressure pipe
- 26. Return sensor
- 27. Flow sensor
- 28. Mains connection box
- 29. Flue sampling point

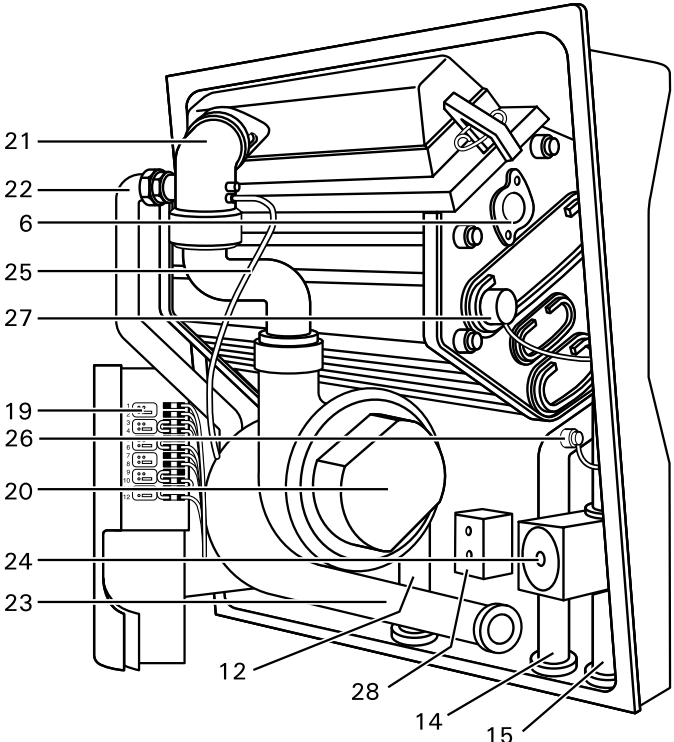

459129

INSTALLATION

7 WALL MOUNTING TEMPLATE

Note. The template shows the positions for the fixing holes. Care must be taken to ensure the correct holes are drilled.

1. Tape template into the selected position.
2. Ensure squareness by hanging a plumbline.
3. Mark onto the wall the screw positions.
4. Remove the template from the wall.
5. Fix the wall bracket into place.

INSTALLATION REQUIREMENTS

The appliance must be installed by a competent person, i.e. CORGI  registered.

The installation of the boiler must be in accordance with the relevant requirements of the Gas Safety Regulations, current I.E.E. Regulations, Model Water Bye-laws, local water authority bye-laws and it should also comply with any relevant requirements of the local gas supplier, local authority and the relevant British Standard Codes of practice and building regulations.

FOR SMALL PIPE INSTALLATIONS;
BS. 6891; Installation of low pressure pipework

8 MOUNTING THE BOILER

1. Remove the jacket:
 - 1 - Pull the door at the front towards you.
 - 2 - Remove the screw (below operating instructions).
 - 3 - Disconnect the fasteners at both sides of the jacket.
 - 4 - Loosen the jacket by pulling it forwards.
Do not lift the jacket by the fasteners.
2. Attach the adaptor plate for the connection of the flue gas discharge and the air supply before mounting the unit.
3. Mount the boiler on the wall bracket. Refer to the next paragraphs for more information about connecting the central heating, gas and flue gas discharge pipes and the condensate drain.

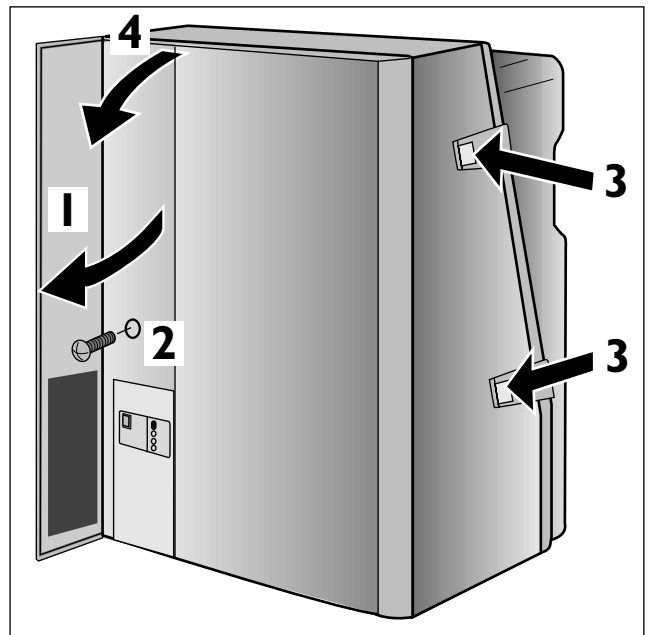

214079

9 VENTILATION

Safe, efficient and trouble-free operation of open flued gas boilers is vitally dependent on the provision of an adequate supply of fresh air to the room in which the appliance is installed. Ventilation by grilles communicating directly with the outside air is required at both high and low levels. The minimum free areas of these grilles must be according to the following scale:

Table 2 - Ventilation Requirements

Minimum air vent free area for compartments:	open-flued appliances		Roomsealed appliances	
	Compartment ventilated:		Compartment ventilated:	
Vent Position	to room or internal space	direct to outside air	to room or internal space	direct to outside air
	cm ² per kW (net.) of appliance maximum rated input	cm ² per kW (net.) of appliance maximum rated input	cm ² per kW (net.) of appliance maximum rated input	cm ² per kW (net.) of appliance maximum rated input
High level	10	5	10	5
Low level	20	10	10	5

Position ventilation grilles to avoid the risk of accidental obstruction by blockage or flooding. If further guidance on ventilation is required then consult BS 5440:2.

Room Sealed Applications

Boilers in this instance will require no additional air for combustion. It may be necessary to ventilate the boiler house in order to remove any additional heat generated by the boiler and pipework. Reference should be made to BS 5440:2 and the requirements for boiler room temperatures.

10 FLUE INSTALLATION

Caution : To avoid the possibility of injury during the use or cleaning of this appliance, care should be taken when handling edges of sheet steel components.

The flue kits are suitable for use with the Ideal Maximiser SE boiler only.

These kits and the associated options are suitable for both roof and wall mounting applications.

The roof kit is suitable for both flat and pitched roof termination, using a concentric flue (tube within tube) to run vertically from the top of the boiler and terminating above the roof level.

Connection to the top of the boiler is made using a separately supplied vertical connector in both concentric and twin pipe configurations.

Additional information covering the selection and installation can be found with this booklet.

WEATHER PROOFING

Where the flue passes through the roof line an adequate seal must be made. This can be achieved by using either:

- Flat roof tile 125 or 150 mm
- Pitched roof tile 125 mm or 150 mm

Concentric flue duct extension kits are available for flue lengths extending beyond 1 metre. These packs contain additional 1 metre ducts and may be cut to the desired length.

If obstructions prevent direct flue routing then both 90° and 45° elbows can be provided to offset the flue system.

TERMINAL POSITION

Due to the high efficiency of the boiler in certain weather conditions pluming will occur. Therefore, where possible, terminal positions which could cause problems should be avoided.

ASSEMBLING THE FLUE

All Concentric flue packs provided contain locking collars for ease of installation (see Frame 11). Extension duct kits are available in 1 metre lengths. These can be cut to suit the required application. The outer duct should be cut to the required length. However, the inner duct MUST be 20 mm greater in length to allow connection to the remainder of the flue.

Important : Only the plain end of the ducts should be removed when cutting to length.

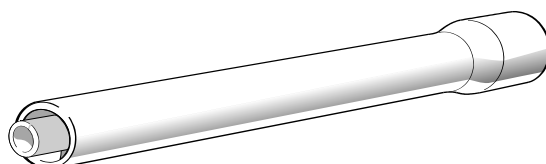

Note : Care should be taken to support the inner duct pipe when cutting the flue.

IMPORTANT

It is the responsibility of the installer to ensure, in practice, that products of combustion discharging from the terminal cannot re-enter the building or any other adjacent building through ventilators, windows, doors, other sources of natural air infiltration, or forced ventilation / air conditioning.

If this should occur the appliance MUST be turned OFF, labelled as 'unsafe' and corrective action taken.

TERMINAL POSITION

Where the lowest part of the terminal is fitted less than 2 m (80") above a balcony, above ground or above a flat roof to which people have access then the terminal MUST be protected by a purpose designed guard. The minimum spacing between the balcony and the terminal should be 75 mm, in order to allow a terminal guard to be fitted.

Terminal guards are available from boiler suppliers and merchants- ask for Tower Flue Guard, Model K1. In case of difficulty seek advice from:

Tower Flue Components Ltd.
Vale Rise, Tonbridge, Kent TN9 1TB
Telephone No. 01732 351 555

Ensure that the guard is fitted centrally.

Where the terminal is fitted within 850 mm (34") of a plastic or painted gutter or 450 mm (18") of painted eaves then an aluminium shield at least 750 mm (30") long should be fitted to the underside of the gutter or painted surface.

The air inlet/products outlet duct and the terminal of the boiler MUST NOT be closer than 25 mm (1") to combustible material. Detailed recommendations on the protection of combustible material are given in BS. 5440: 1990.

11 FLUE KITS

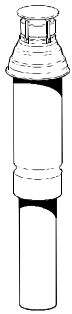

Fig. 11.1

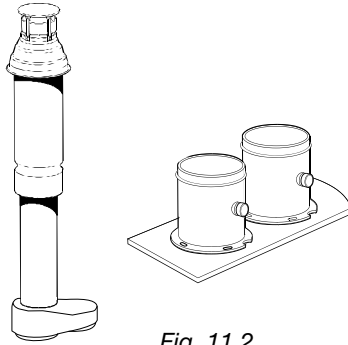

Fig. 11.2

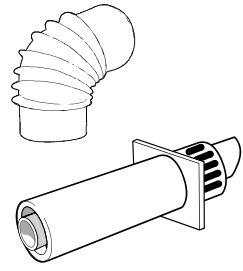

Fig. 11.3

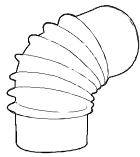

Fig. 11.4

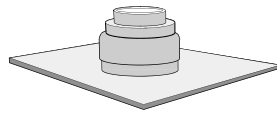

Fig. 11.5



Fig. 11.6

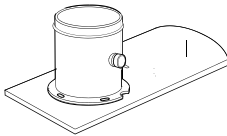

Fig. 11.7

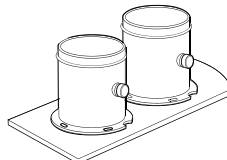

Fig. 11.8

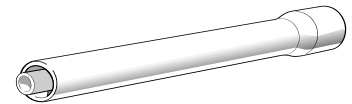

Fig. 11.9

Table 3

KEY TO DIAGRAM	DESCRIPTION	CODES	
		80/125 mm	100/150 mm
Fig. 11.1	Vertical Roof Kit	152394	152 395
Fig. 11.2	Vertical Twin Pipe Roof Kit	152396	152 397
Fig. 11.3	Horizontal Wall Kit	152398	152 399
Fig. 11.4	90° Elbow (shown)	152616	152617
Fig. 11.4	45° Elbow	152618	152619
Fig. 11.5	Flat Roof Tile (shown)	152611	152612
Fig. 11.5	Pitched Roof Tile	152609	152610
Fig. 11.6	Locking Collar	Supplied within wall & roof kits	
Fig. 11.7	Concentric Flue Adaptor	Supplied within wall & roof kits	
Fig. 11.8	Twin Pipe Adaptor	152403	N/A
Fig. 11.9	1 m Extension kit	152400	152401
Not Shown	Increaser 80/100	152404	N/A
Not Shown	Air inlet grille	152402	N/A

The Vertical and Horizontal flue kits are supplied with all the necessary components to allow the connection of the concentric flue system from the boiler to the outside atmosphere. The kits are supplied with a maximum length of 1 metre. For lengths greater than 1 metre extension kits will need to be obtained.

12 FLUE RESISTANCE'S

IMPORTANT : The boiler MUST be installed in a vertical position.

The pressure available at the boiler outlet is sufficient to overcome the resistance of approximately 40 metres of 100 mm smooth straight flue pipe. However, this pressure will be significantly reduced dependant upon the type of flue system used and the number of bends.

The table below provides the individual resistance's for a number of pipes and bends available.

The maximum pressure drop allowed in the flue length is approximately:-

70 Pa for the Maximiser SE42

90 Pa for the Maximiser SE65

Table 4 - Flue Gas Resistance

Pressure drop per component	Pa SE42	Pa SE65		SE42	SE65
			Straight pipe Ø 80 mm per m	2.2	5.3
Ducts			Straight pipe Ø 90 mm per m	1.8	4.4
Roof duct 80/125 mm	34.0	75.2	Straight pipe Ø 100 mm per m	0.8	1.7
Roof duct 100/150 mm	-	37.0	Straight pipe Ø 110 mm per m	0.3	0.7
Wall duct 80/125 mm	22.0	-			
Wall duct 100/150 mm	-	43.3	Air supply system		
Concentric pipe			45° bend Ø 80 mm	2.3	5.3
45° bend Ø 80/125 mm	3.7	-	45° bend Ø 90 mm	1.7	4.1
45° bend Ø 100/150 mm	1.8	2.7	45° bend Ø 100 mm	0.7	1.6
90° bend Ø 80/125 mm	6.0	-	45° bend Ø 110 mm	0.2	0.5
90° bend Ø 100/150 mm	2.7	4.5			
Straight pipe Ø 80/125 mm per m	4.0	-	90° bend Ø 80 mm	7.2	16.0
Straight pipe Ø 100/150 mm per m	1.8	3.6	90° bend Ø 90 mm	5.4	12.5
			90° bend Ø 100 mm	2.2	4.4
Flue gas discharge system			90° bend Ø 110 mm	0.3	0.6
45° bend Ø 80 mm	3.7	8.9			
45° bend Ø 90 mm	2.8	6.7	Straight pipe Ø 80 mm per m	1.5	3.6
45° bend Ø 100 mm	0.9	2.0	Straight pipe Ø 90 mm per m	1.3	3.1
45° bend Ø 110 mm	0.4	0.9	Straight pipe Ø 100 mm per m	0.6	1.4
			Straight pipe Ø 110 mm per m	0.1	0.2
90° bend Ø 80 mm	11.7	26.6			
90° bend Ø 90 mm	9.0	20.0			
90° bend Ø 100 mm	3.5	7.2			
90° bend Ø 110 mm	0.5	1.1			

The above table provides approximate resistance information for the optional flue kits (concentric pipe) and propriety fittings, available from the flue companies mentioned below.

Purpose designed flue and air systems can be provided with the boiler (concentric systems) at the time of purchase, or can be purchased from either of the following:

Rite Vent Ltd (0191) 416 1150
Selkirk Manufacturing (01737) 353388

FLUE DESIGNS

Flue designs are calculated against the maximum available resistance using the resistance table above. The examples following are given as a guide only, therefore a greater number of variations can be obtained.

13 EXAMPLES OF POSSIBLE FLUE INSTALLATIONS

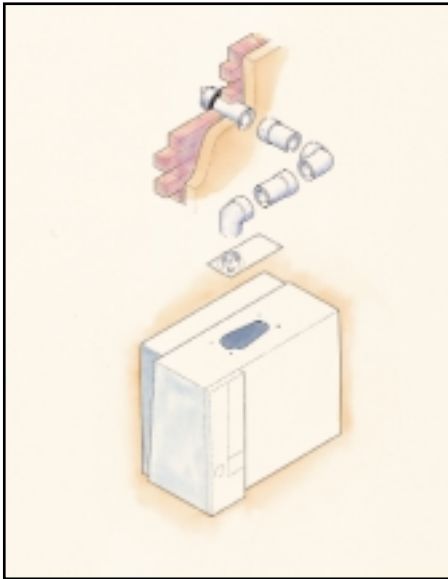

Fig.13.1

NOTE: FOR MAXIMUM PRESSURE DROPS SEE FRAME 12

horizontal flue with 1x90° elbow

Flue diameter	Part No.		Resistance Pa		
	80/125	100/150	SE 42		SE 65
			80/125	100/150	100/150
Standard flue	152398	152399	22	22	43.3
+ 2 x Extension packs	152400	152401	8	3.6	7.2
+ 1 x 90° elbow	152616	152617	6	2.7	4.5

approximate length - right 2300mm; left 2000mm; rear 2500mm

Note: lengths are from side/back of boiler

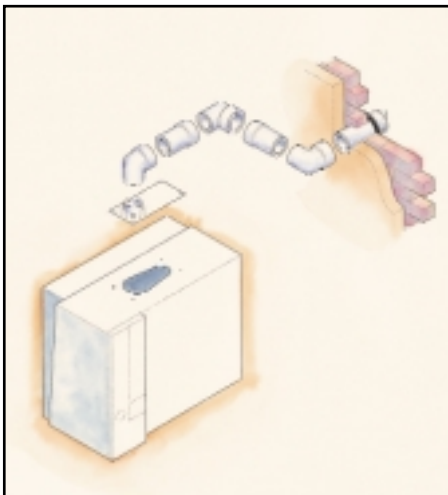

Fig.13.2

horizontal flue with 2x90° elbows

Flue diameter	Part No.		Resistance Pa		
	80/125	100/150	SE 42		SE 65
			80/125	100/150	100/150
Standard flue	152398	152399	22	22	43.3
+ 2 x Extension packs	152400	152401	8	3.6	7.2
+ 2 x 90° elbows	152616	152617	12	5.4	9

approximate length - right 2300mm; left 2000mm; rear 2300mm

Note: lengths are from side/back of boiler

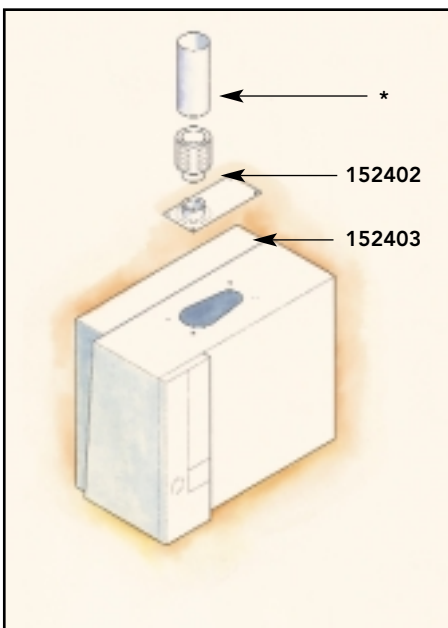

Fig.13.3

open flue

Flue diameter	Part No.		Resistance Pa	
	80/125	80/125	SE 42	SE 65
			80/125	80/125
Twin pipe adaptor	152403	n/a	n/a	n/a
Air inlet grille	152402	5	5	5
6m of 80mm pipe	n/a	13.2	31.8	31.8

approximate length - 6000mm

Note: * Flue system supplied by proprietary flue manufacturers. This flue design layout would be used where greater flue travel is required. By utilizing the twin pipe adaptor and air inlet grille, as shown in the diagram, proprietary flue lengths can be used to take the flue gases to the external atmosphere.

It should be noted that in this example the combustion air is drawn from the room the boiler is situated in, therefore the boiler will need to be positioned in a purpose built boiler room with additional air inlet grilles

13 EXAMPLES OF POSSIBLE FLUE INSTALLATIONS (CONT)

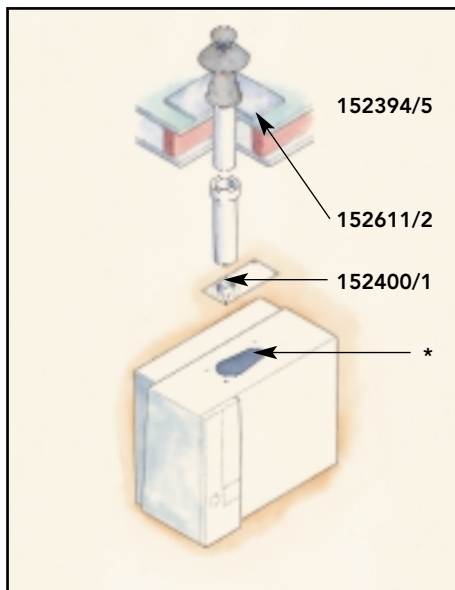

Fig.13.4

roof flue system

Flue diameter	Part No.		Resistance Pa		
	80/125	100/150	SE 42		SE 65
			80/125	100/150	100/150
Standard flue	152394	152395	34	34	37
approximate length - 1000mm					
Standard flue	152394	152395	34	34	37
+ Extension pack	152400	152401	4	1.8	3.6
approximate length - 2000mm					
Standard flue	152394	152395	34	34	37
+ 3 x Extension packs	152400	152401	12	5.4	10.8
approximate length - 4000mm					
Standard flue	152394	152395	34	34	37
+ 6 x Extension packs	152400	152401	24	10.8	21.6
approximate length - 7000mm					

Note: * The twin pipe adaptor is supplied within the standard flue pack for connection to the boiler

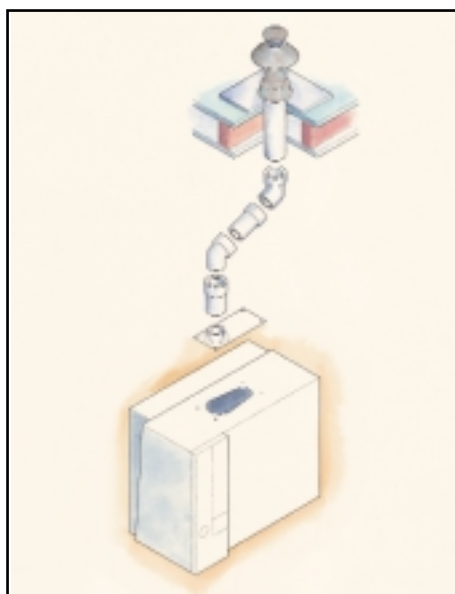

Fig.13.5

roof flue system with 2x45° elbow

Flue diameter	Part No.		Resistance Pa		
	80/125	100/150	SE 42		SE 65
			80/125	100/150	100/150
Standard flue	152394	152395	34	34	37
+ 2 Extension packs	152400	152401	8	3.6	7.2
+ 2 x 45° elbows	152618	152619	7.4	3.6	5.4
approximate length - 3500mm					
Standard flue	152394	152395	34	34	37
+ 3 x Extension packs	152400	152401	12	5.4	10.8
+ 2 x 45° elbows	152618	152619	7.4	3.6	5.4
approximate length - 4500mm					

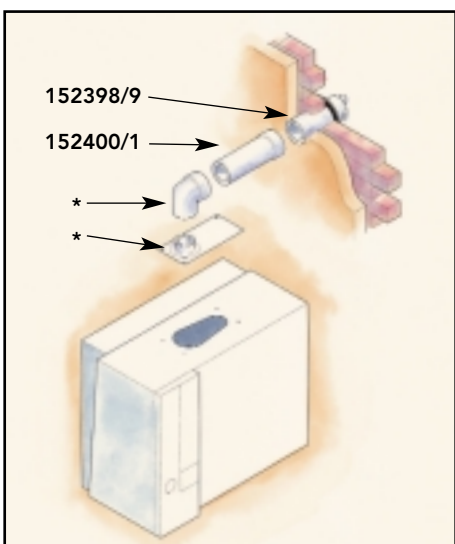

Fig.13.6

horizontal flue

Flue diameter	Part No.		Resistance Pa		
	80/125	100/150	SE 42		SE 65
			80/125	100/150	100/150
Standard flue	152398	152399	22	22	43.3
approximate length - right 300mm; left n/a; rear 500mm					
Standard flue	152398	152399	22	22	43.3
+ Extension pack	152400	152401	4	1.8	3.6
approximate length - right 1300mm; left 1000mm; rear 1500mm					
Standard flue	152398	152399	22	22	43.3
+ 3 x Extension packs	152400	152401	12	5.4	10.8
approximate length - right 3300mm; left 3000mm; rear 3500mm					

Note: items * are provided with the standard flue pack

14 FLUE TERMINATION POSITION

wall terminal positions

minimum spacing

1. Directly below, or adjacent to, an openable window or any other ventilation opening	300 mm	12 in
2. Below guttering, drain pipes, or soil pipes	25 mm	1 in
3. Below eaves	25 mm	1 in
4. Below balconies or car port roof	25 mm	1 in
5. Above adjacent ground, roof, or balcony level	300 mm	12 in
6. From vertical drain pipes or soil pipes	25 mm	1 in
7. From internal or external corners	25 mm	1 in
8. From a surface facing the terminal	600 mm	24 in
9. From a terminal facing the terminal	1200 mm	48 in
10. From an opening in the car port (eg door, window) into dwelling	1200 mm	48 in
11. Vertically from a terminal on the same wall	1500 mm	60 in
12. Horizontally from a terminal on the same wall	300 mm	12 in

roof terminal positions

13. Directly below an opening, air brick, windows, etc	300 mm	12 in
14. Below plastic/painted gutters	500 mm*	20 in
15. Below painted surface	500 mm*	20 in
16. Below eaves or balcony	500 mm	20 in
17. From wall	1000 mm	

*Note: may be reduced to 300mm if a shield fitted

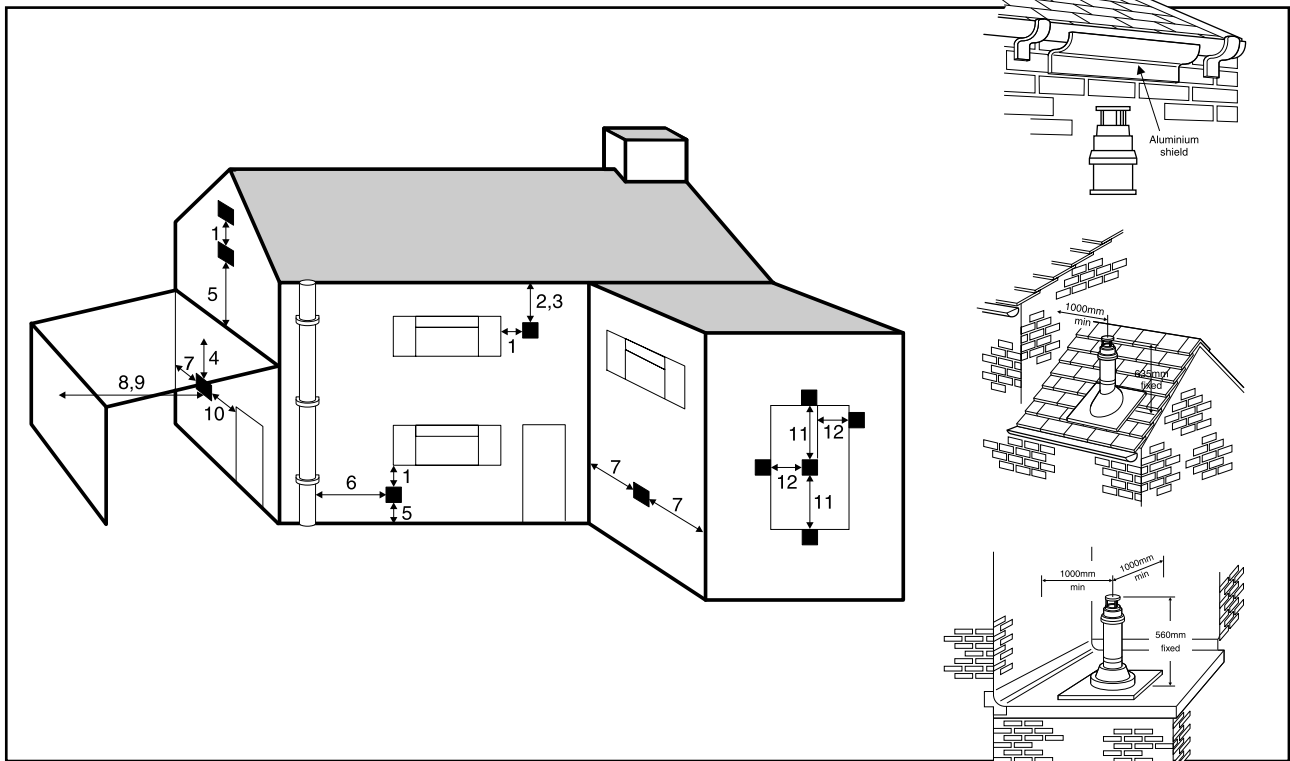

Note: the flue must be installed in accordance with BS 5440: Part 1

15 CASCADE FRAME KITS

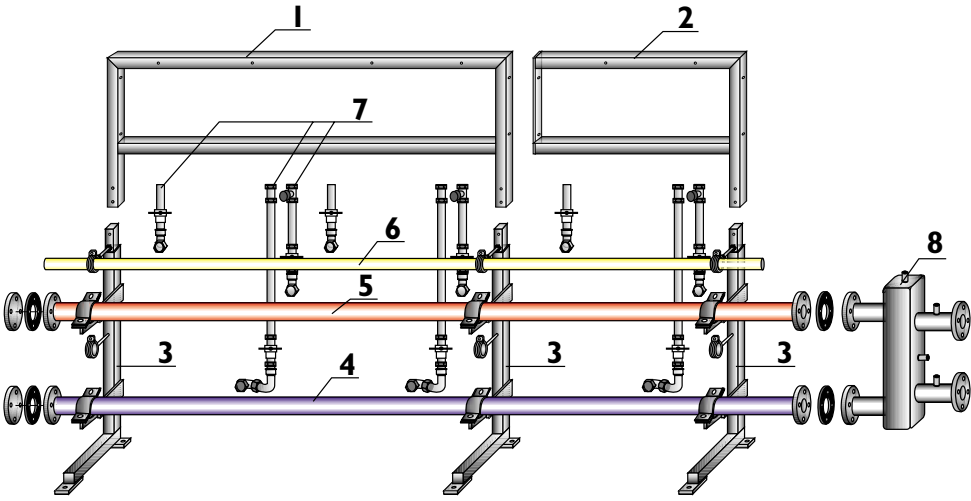

- KEY**
- 1. 2 boiler basic frame
 - 2. additional single frame
 - 3. support foot
 - 4. main return pipe
 - 5. main flow pipe
 - 6. main gas supply pipe
 - 7. boiler connection kit
 - 8. hydraulic header

499004

2 and 3 Boiler Frame Kits, shown above, are available as options to mount the boilers remote from the wall of the boiler house.

16 INSTALLATION OF MULTIPLE BOILERS

In installations where the heat load is greater than the boiler capacity an ideal solution is to use multiple boiler arrangements.

There are many variations available to suit most commercial applications.

Multiple boiler layout incorporating room sealed application.

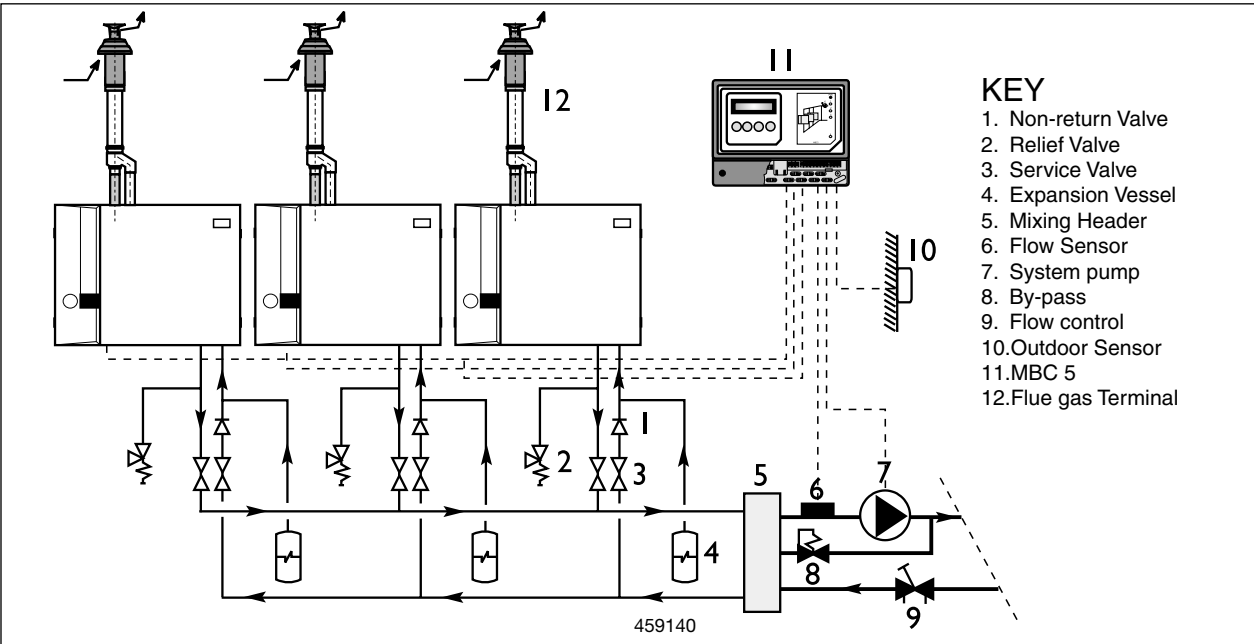

- KEY**
- 1. Non-return Valve
 - 2. Relief Valve
 - 3. Service Valve
 - 4. Expansion Vessel
 - 5. Mixing Header
 - 6. Flow Sensor
 - 7. System pump
 - 8. By-pass
 - 9. Flow control
 - 10. Outdoor Sensor
 - 11. MBC 5
 - 12. Flue gas Terminal

459140

Modular flue arrangements using a single combined header can be used. For further advice or additional information on multiple arrangements contact **Caradon Ideal Ltd.**

INSTALLATION

17 PUMP SPECIFICATION

The boiler is fitted with a Grundfos UP 25/55 circulating pump, which provides circulation through the boiler heat exchanger. Some pump pressure remains available for the system and is shown on the graphs below.

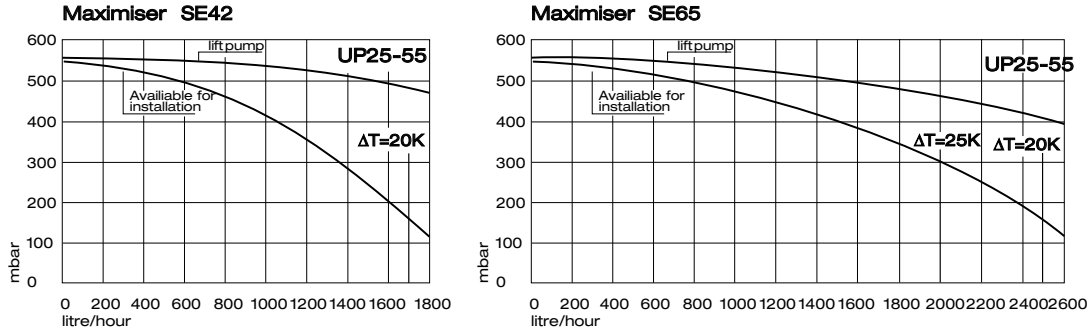

459141

If this pressure is not sufficient an additional pump to overcome system resistance must be fitted. (see frames 3 & 4 for pump positions)

Fig. 17.1 Automatic air-vent.

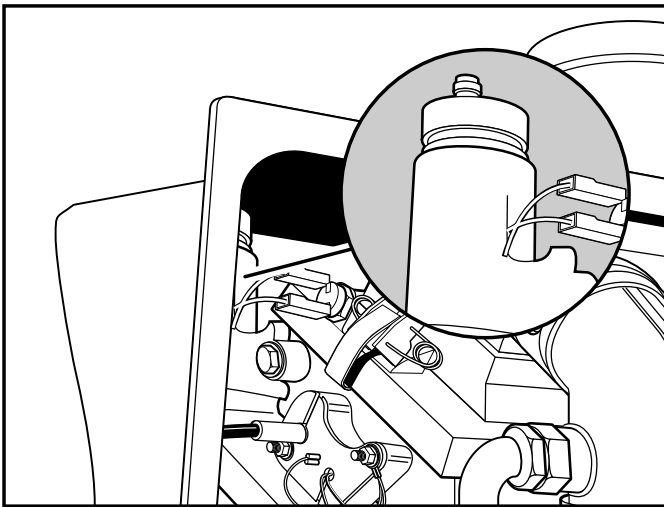

211084

Fig. 17.2 Schematic diagram of installation, with remote shunt pipe and differential pressure valve.

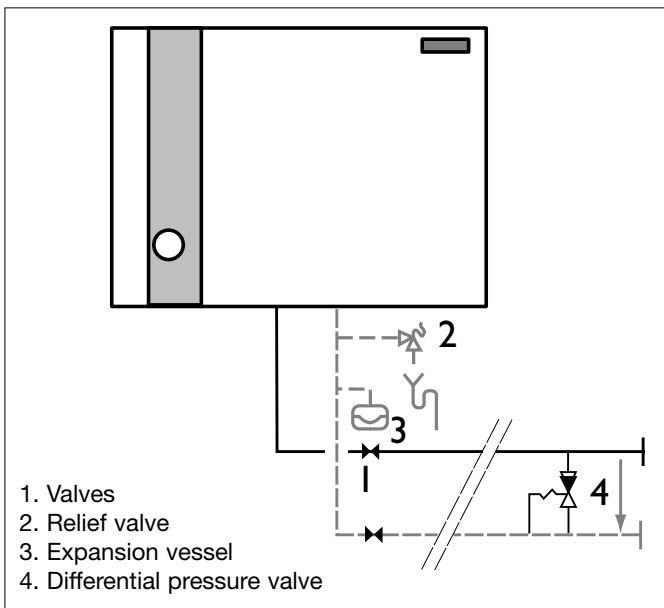

216034 UK

Central heating circuit

The connections for the return pipe and the flow pipe of the central heating circuit are located at the bottom right side of the unit. The return pipe has a blue mark, the supply pipe a red mark. It is recommended to connect the unit to the pipe system by means of valves.

If applicable select the size of the expansion vessel, depending on the central heating water temperature, the total water volume of the installation and the static water pressure. The boiler has been equipped with an automatic air-vent. This vent is located in the left top side wall of the heat exchanger. (Refer to Fig. 17.1).

A pressure safety device is necessary, too. The pressure safety device has to be installed in the flow pipe.

In installations at which all radiators have been provided with thermostatic radiator valves, you need to ensure that the water circulation through the unit is guaranteed. This can be done by means of a differential pressure valve, that is installed between the supply pipe and the return pipe at about 6 meters distance from the unit. The pipe diameter has to be at least 22 mm for an installed capacity of 22 and 30 kW and 28 mm for an installed capacity of 42 kW or over. (Refer to Fig 17.2).

The Ideal Maximiser is not suited for installations with a natural water circulation (gravity installations).

Important information:

Corrosion in the central heating system depends on:

- the water quality,
- not flushing old installations when installing a new boiler,
- intrusion of oxygen through leakages or open valves,
- diffusion in synthetic (floor) heating systems.

The changing temperature and pressure in the system can also accelerate the corrosion.

If the Ideal Maximiser is to be installed in an existing installation, the central heating water has to be checked in advance. If this water is contaminated, the whole installation has to be drained and flushed before the unit can be mounted and the system filled.

Do not use system additives. (refer to frame 5, page 6)

18 CONDENSATE DRAIN

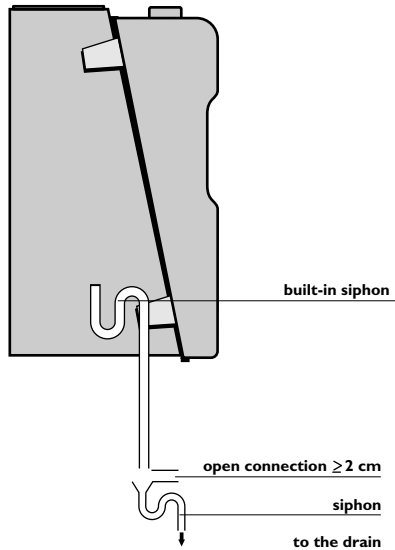

21105 UK

Note.

The drain connection is located at the bottom left of the casing.

The condensate drain provided on the boiler must be connected to a drainage point, preferably within the building.

The routing of the drain must be made to allow a minimum fall of 1 in 20 away from the boiler, throughout its length.

IMPORTANT.

Any external runs must be insulated.

In order to defer the onset of freezing of the condensate drain when the pipe is run externally the pipe should be run as far as possible within the building.

Excessive external pipe runs should be avoided in order to prevent possible freezing.

All pipework and fittings in the condensate drain system must be made of plastic. No other materials may be used.

The drain outlet on the boiler is standard 32 mm overflow pipe. This size must not be reduced in any part of its length.

The boiler condensate drain connection should be sealed to the tubing, using a suitable plastic tube adhesive.

The use of an open tundish is recommended to prevent condensate building up inside the boiler.

19 ELECTRICAL CONNECTIONS

WARNING. This appliance **MUST** be efficiently earthed.

A mains supply of 230 V ~ 50 Hz is required.

The supply wiring **MUST** be suitable for mains voltage. Wiring should be 3 core PVC insulated cable **NOT LESS** than 0.75 mm² (24 x 0.2 mm) and to BS. 6500, Table 16.

Wiring external to the boiler **MUST** be in accordance with the current I.E.E. Wiring Regulations and any local regulations.

The supply connection is intended to be made via a double pole switch, having a 3 mm (1/8") contact separation in both poles, serving only the boiler and system controls.

The fuse rating should be 3 A.

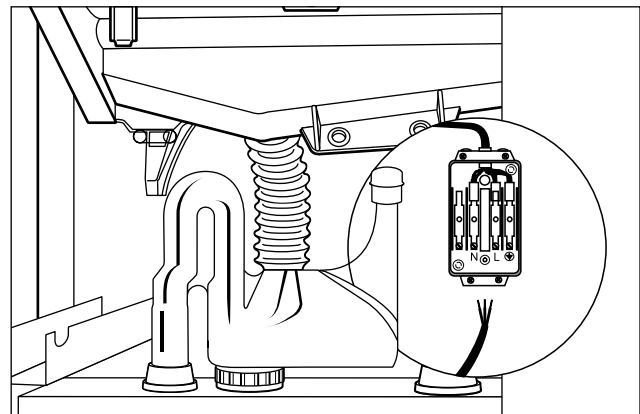

459139

20 EXTERNAL WIRING

N.B. All secondary controls, such as room thermostats, programmers etc., used with this boiler **MUST** be volt free or 24 volt. Do not connect mains voltage via the boiler secondary control connections.

External wiring **MUST** be in accordance with the current I.E.E. Wiring Regulations.

The wiring diagrams illustrated in Frames 22 to 23 cover the systems most likely to be used with this appliance.

For wiring external controls to the boiler, reference should be made to the systems wiring diagram supplied by the relevant manufacturer in conjunction with the wiring diagrams shown in Frames 22 to 23.

Difficulty in wiring should not arise, providing the following directions are observed:

1. It is advised that the appliance is wired with an unswitched (permanent) live supply.
2. External controls should **NOT** be wired in series with the boiler mains input. Controlling the mains input in this way prevents the internal pump from performing its over-run sequence and may cause damage to the heat exchanger.

3. Caradon Ideal Ltd. Recommend the use of the iRT30 programmable room thermostat or the MBC5 sequence controllers.
4. However, if alternative external timers/controllers are to be used, volt free contacts should be wired across terminals 1&2.
5. **DO NOT connect mains voltage across terminals 1&2.**
6. If no external controls are fitted, a link must be used to replace the factory fitted 'loop' across terminals 1 & 2.
6. Controls that override an on/off control, e.g. a frost thermostat, Must be wired in parallel with the controls to be overridden.
8. **SYSTEM DESIGNS FEATURING CONTROLS OR WIRING ARRANGEMENTS WHICH ALLOW THE BOILER TO FIRE WHEN THERE IS NO PUMPED CIRCULATION TAKING PLACE MUST NOT BE FITTED.**

Advice be obtained from the component manufacturers.

INSTALLATION

21 INTERNAL WIRING

A pictorial wiring diagram is shown.

1. Route the mains cable into the bottom of the casing.
2. If an on/off room thermostat is to be fitted remove plastic link across 1 & 2 and connect wires to terminals 1 & 2.

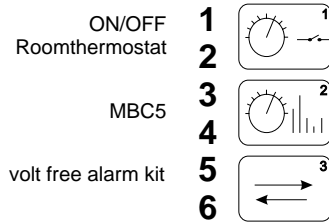

211090 UK / 211093 UK

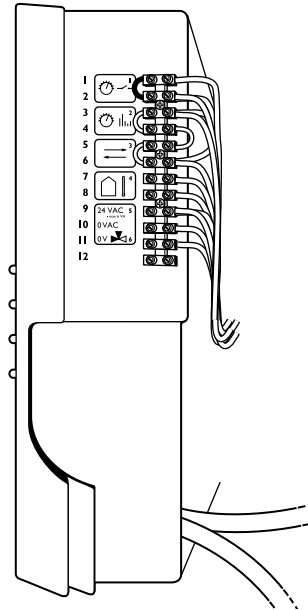

211292

22 PICTORIAL WIRING

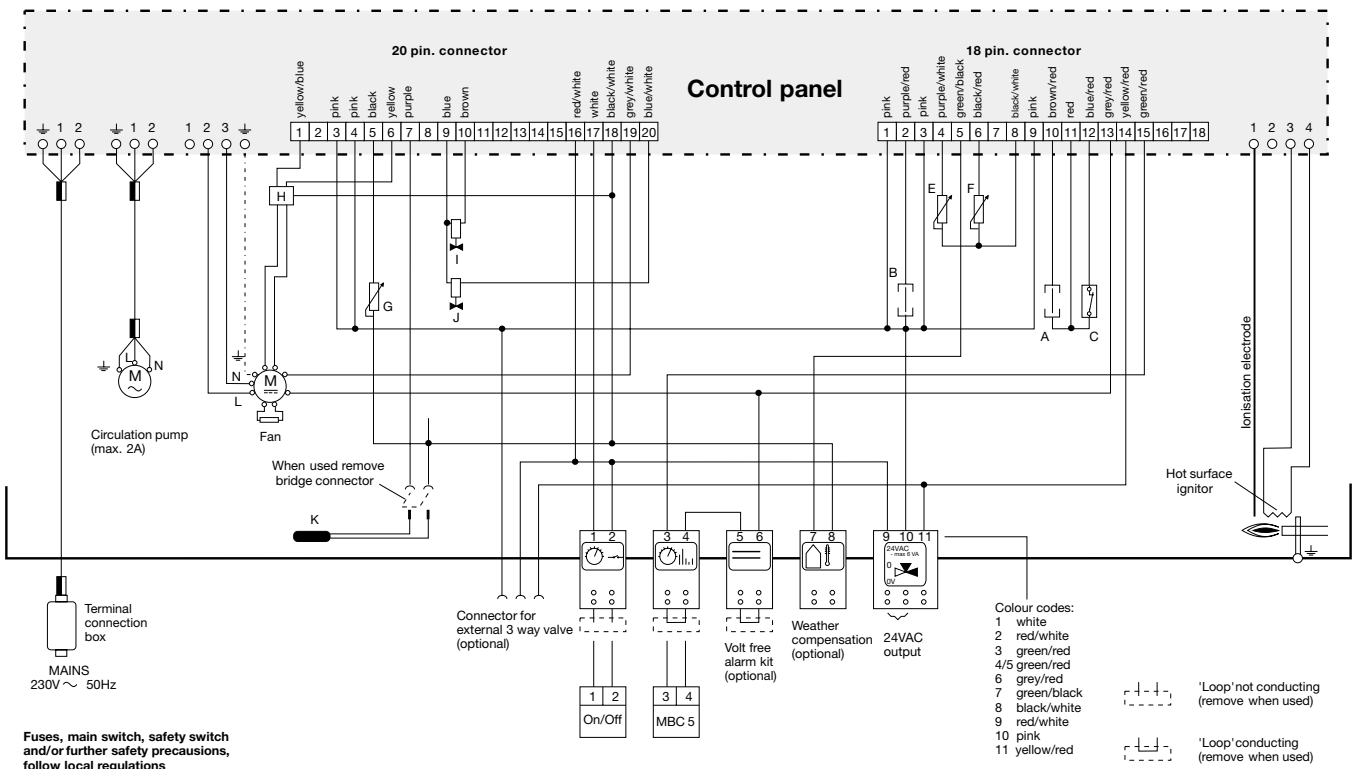

Fuses, main switch, safety switch and/or further safety precautions, follow local regulations

Note!

- 1) Only 1 external controller may be connected.
- 2) Only 1 controller. MBC5 may be connected.

- A Flue gas temperature limiter (optional)
 B Potential free connection (bridge connector)
 C Burner safety protection
 D Not present
 E Return sensor
 F Safety sensor
 G Supply sensor
 H Boiler identification module
 I ignition gas valve
 J main gas valve
 K hot water tank sensor kit

219053 [Caradon]

23 FROST PROTECTION

Central heating systems fitted wholly inside the building do not normally require frost protection as it acts as a storage heater.

The Maximiser SE boiler has built into its control system the facility to protect the boiler against freezing. The frost protection will be actioned when the boiler thermostat drops below 7 °C. This will result in the boiler switching on until its temperature raises to 17 °C.

If a frost protection thermostat is to be fitted, remove plastic link across 1 & 2 and connect wires to terminals 1 & 2. This must be a Normally Open thermostat!

24 PUMP OPERATION (INTERNAL)

The Maximiser SE is provided as standard with an internal circulation pump manufactured by Grundfos.

The pump has been preset and therefore should not be adjusted as this could have a detrimental effect on the operation of the boiler.

The control system built into the boiler provides the facility for pump overrun which can be adjusted between continuous or 4 minutes after the boiler has ceased firing. If the unit has not operated for long periods the control system will operate both the pump and the fan for 5 minutes once every 24 hours.

Pump overrun adjustment is shown in the diagram
 1 = 4 minutes
 2 = Continuous

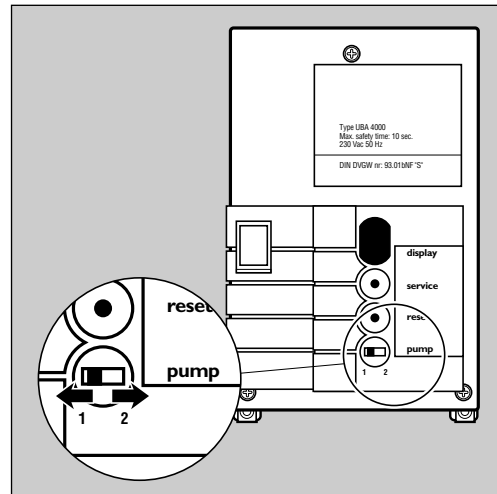

211079

25 COMMISSIONING AND TESTING

A. Electrical Installation

1. Checks to ensure electrical safety should be carried out by a competent person.
2. ALWAYS carry out the preliminary electrical system checks, i.e. earth continuity, polarity, resistance to earth and short circuit, using a suitable test meter.

WARNING. Whilst effecting the required gas soundness test and purging air from the gas installation, open all windows and doors, extinguish naked lights and DO NOT SMOKE

B. Gas Installation

1. The whole of the gas installation, including the meter, should be inspected and tested for soundness and purged in accordance with the recommendations of BS. 6891.
2. Purge air from the gas installation by loosening the gas cock union and purge until gas is smelt.
3. Retighten the union and test for gas soundness.

26 GAS CONNECTION

Refer to Frame 2 for details of the position of the gas connection.

A MINIMUM working gas pressure of 20 mbar (8" w.g.) must be available at the boiler inlet with the boiler firing. Refer to Frame 31 or 'Servicing' for details of the pressure test point position.

Extend a gas supply pipe NOT LESS THAN 15 mm O.D. to the boiler and connect to a gas service cock (not supplied), situated at the bottom left hand side of the boiler.

Ensure that the gas supply pipe does not foul the boiler casing.

Note. If the pipe run from the meter to the boiler is greater than 3 m (10') it is recommended that 22 or a 28 mm O.D. pipe is used.

A 1/2" BSP x 15 mm connector, pre-fitted with a short stub connection, should be screwed into the cock, using a suitable sealant.

IMPORTANT. The gas service cock may contain a non-metallic seal so must not be overheated when making capillary connections.

INSTALLATION

27 INITIAL LIGHTING

1. Check that the system has been filled and that the boiler is not air locked - air in the system could trip the overheat thermostat.
2. Check that all the drain cocks are closed and any valves in the flow and return are open.
3. Check that the GAS SERVICE COCK IS ON.
4. Fill the siphon beaker with water before putting the unit into operation (see frame 32 for siphon removal). Check the indication on the pressure gauge. If the pressure is less than 1 bar, the installation should be filled up first.
5. Switch the electricity supply ON and check that all external controls are calling for heat.
6. The gas control solenoid valve should open and ignition commence, continuing until the burner is established.
7. Test for gas soundness around ALL boiler gas components, using leak detection fluid.
8. Operate the boiler for 20 minutes to stabilise the burner temperature.
9. The boiler is preset at the factory, therefore no adjustments should be necessary. However, if problems are experienced refer to Frame 31.

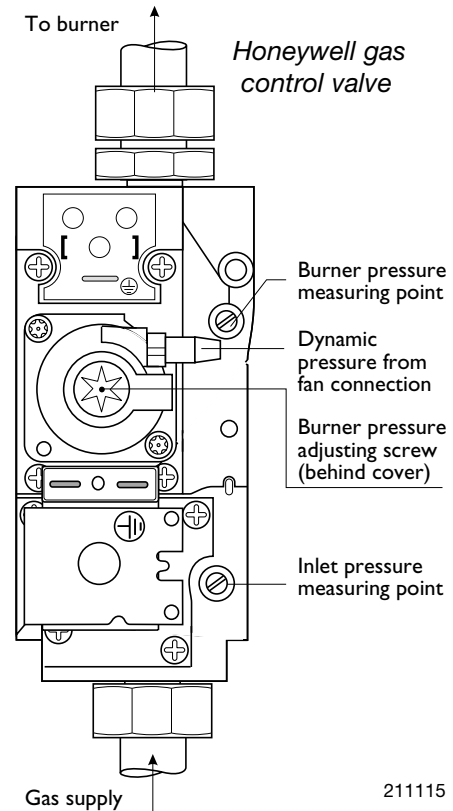

211115

28 GENERAL CHECKS

A number of adjustments can be carried out on the boiler. These adjustable potentiometers are located behind the control panel cover. Adjustment of these meters to the desired value will be dependant upon the type of installation.

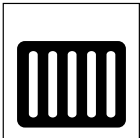

Supply temperature

1. Supply temperature
Using the upper trimming potentiometer, indicated with a radiator, to adjust the central heating water temperature. This temperature can be adjusted between 40 °C to 90 °C.

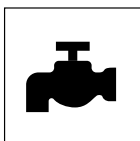

Hot water storage temperature

2. Storage temperature hot water
Only used when fitted with integral DHW calorifier.



Partial load

3. Partial load
Use the potentiometer to adjust the maximum power. The highest adjustment corresponds with a 100% capacity, the lowest adjustment corresponds with a 30% capacity (refer to table 1).

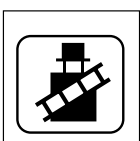

Test switch

You will also find a test switch on the control panel, indicated with a chimney sweep symbol. During normal operation this switch has to be in the "0"- position. For service purposes the test switch can be put in the upper position. The unit will then be heated at maximum power.

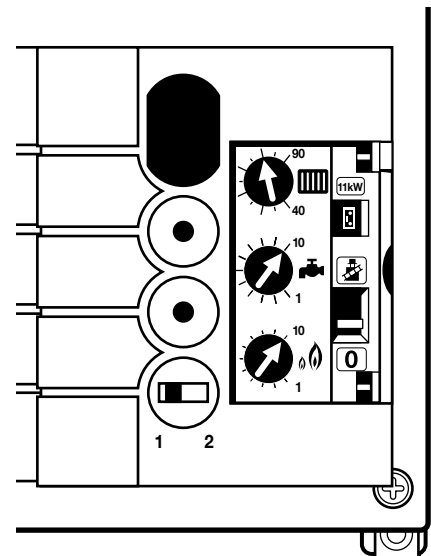

211076

499003 UK

29 ADJUSTMENT PARAMETERS

Table 5

Hot water tank temperature adjustment
(only in case of an external hot water tank)

Potentiometer adjustment	Water temperature in hot water tank (°C)
1	27
2	31
3	34
4	38
5	41
6	45
7	49
8	52
9	56
10	60

Table 6

Capacity (kW) partial load adjustment at 80/60°C

Potentiometer adjustment	kW	kW
	SE42	SE 65
1	12.6	18.0
2	15.6	22.5
3	18.7	26.6
4	21.7	31.3
5	24.8	35.9
6	27.8	40.6
7	30.9	45.4
8	33.9	50.2
9	37.0	55.1
10	40.0	60.0

30 GENERAL CHECKS

Make the following checks for correct operation

1. The correct operation of ANY programmer and all other system controls should be proved. Operate each control separately and check that the main burner or circulating pump, as the case may be, responds.
2. Water circulation system:
 - a. With the system HOT examine all water connections for soundness.
 - b. With the system still HOT, turn off the gas, water and electricity supplies to the boiler and drain down to complete the flushing process.
 - c. Refill and vent the system, clear all air locks and again check for water soundness.
 - d. Balance the system.
3. Check the condensate drain for leaks and check that it is discharging correctly
4. Finally set the controls to the User's requirements.
 - If an optional programmer kit is fitted then refer to the instructions supplied with the kit.

INSTALLATION

31 BOILER ADJUSTMENTS

Fig. 31.1

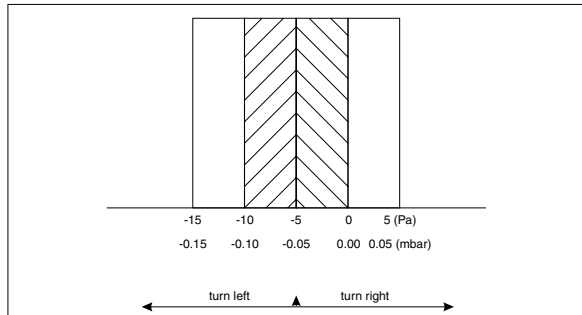
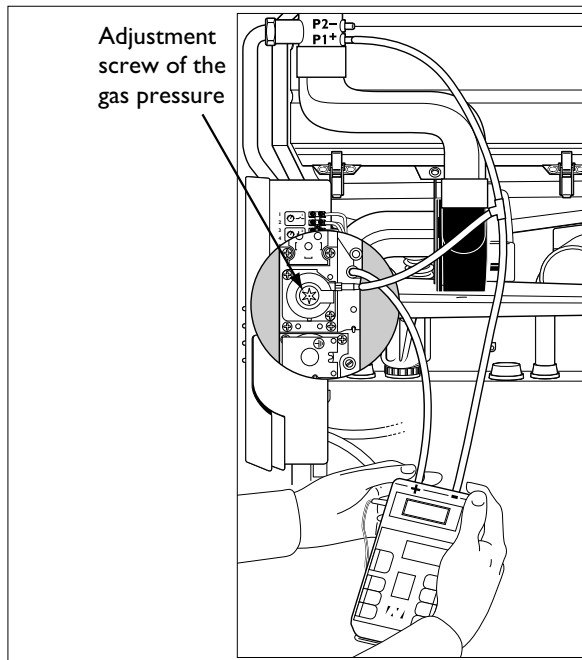
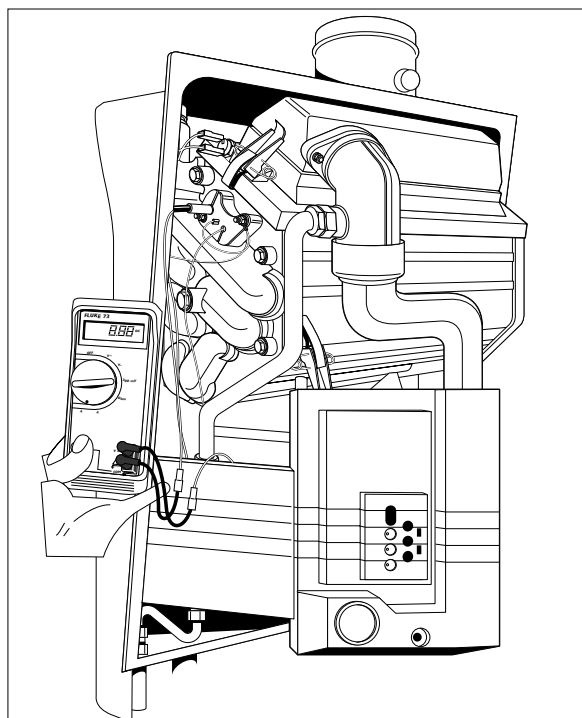

Fig. 31.2 Measuring the differential pressure P1



459136 [Eng]

Fig. 31.3 Measuring the ionization current



219048

General

The Maximiser constantly controls the gas/air mixture. In order to maintain the correct output and low emissions it is important to have the initial adjustment correct, thus avoiding high/low operation and/or bad emissions.

Although the boiler has been factory set, starting problems can be caused by a variation of the gas/air pressure ratio. The set value of the pressure difference between the gas pressure and the air pressure should be -5 Pa (-0.05 mbar) at low load. A tolerance of $\pm 5 \text{ Pa}$ is allowed on this value (see fig. 31.1).

To check the setting and make any adjustments proceed as follows.

- Disconnect the main electricity supply.
- Connect a hose from the -ve measuring point of the pressure gauge to the P1+ connection of the gas/air connection piece on the boiler. Insert a T-piece in the hose (see fig 31.2).
- Connect a hose from the T-piece to the 'Dynamic pressure from fan' connection on the gas valve (see frame 27).
- Connect a hose from the +ve measuring point of the pressure gauge to the burner pressure measuring point on the gas valve after opening the test point with a suitable screwdriver.
- Remove the cover from the control panel.
- Move the service switch to the upper position
- Re-connect the electricity supply. The boiler will now light.
- When the boiler is firing, press the service button for 5 seconds until the letter Y shows on the display.
- Turn the middle potentiometer to position 1 (low load = 30% constant).
- The Maximiser boiler will operate constantly and is now ready to be adjusted.

Measuring the differential pressure

The differential pressure should be -5 Pa (-0.05 mbar) with a tolerance of 5 Pa (0.05 mbar). Because of this the measured value should be between -10 and 0 Pa .

The differential pressure can be corrected by turning the adjustment screw of the gas pressure on the gas valve. By turning it to the right, the differential pressure will decrease.

Note: The adjustment screw is protected by a star-shaped cover on the Honeywell gas valve. This cover has to be removed, before an adjustment can be made (see frame 27).

The adjustment screw can be turned by means of a Torx-bit T40H.

Use the proper tools before making an adjustment

Note: If the hoses have been connected the opposite way round to the gas valve or the pressure gauge, the following abnormality will occur. By turning the adjustment screw of the gas pressure on the gas valve to the right, the differential pressure will increase.

After finishing the pressure measurements, the pressure measuring nipples have to be sealed properly. Turn the potentiometer to the desired setting. Set the test switch to the '0' position. Put the cover on the control box. Check the disconnected gas couplings for gas leakage.

Measuring the ionization current at full load

Before the ionization current can be measured, the plug connection in the ionization cable has to be disconnected. Measure the ionization current in series on the contacts of the two plugs. The ionization current should be at least $2 \mu\text{A}$ (Fig. 31.3).

32 SERVICING SCHEDULE

WARNING.

BEFORE SERVICING always turn OFF the gas supply at the gas service cock and switch OFF and DISCONNECT the electrical supply to the appliance.

To ensure the continued safe and efficient operation of the appliance it is recommended that it is checked at regular intervals and serviced as necessary. The frequency of servicing will depend upon the installation condition and usage but should be carried out at least annually.

It is the law any service work must be carried out by a CORGI registered installer.

- a. Light the boiler and carry out a pre-service check, noting any operational faults.
- b. Operate the boiler for at least 20 minutes. Check the gas consumption.
- c. Connect a suitable gas analyser to the sampling point on the flue collector. Refer to frame 6.
For correct operation the CO/CO₂ content of the flue gas should not be greater than 0.004 ratio. If this is the case and the gas input is within 95% of the nominal then no further action need be taken. If not the case, proceed to step (d).
- d. Clean the main burner.
- e. Clean the heat exchanger.
- f. Clean the main injectors.
- g. Check that the flue terminal is unobstructed and that the flue system is sealed correctly.
- h. If the appliance has been installed in a compartment, check that the ventilation areas are clear.

The servicing procedures are covered more fully in Frames 33 and 34 and **MUST** be carried out in sequence.

Note. In order to carry out either servicing or replacement of components, the boiler casing must removed. Refer to frame 8.

IMPORTANT. After completing the service or exchange of components always test for gas soundness and carry out functional checks as appropriate.

When the work is complete the casing **MUST** be correctly refitted and secured.

The boiler must **NOT** be operated if the casing is not fitted.

In order to determine the level of maintenance required the following checks can be carried out:

- 1. Measuring the differential pressure (refer to fig. 33.1).**
Put the test switch on the control panel in the upper position, the unit will now be operational at full power. Measure the differential pressure between the measuring points P1+ and P2- on the burner lid (refer to Fig. 32.1).
Insert a T-piece in the P1+ connection. Next, connect the T-piece to the fan dynamic pressure connection on the gas valve. Remove the screw before connecting the measuring hose to P2-. The screw and the seal should be kept. If the ΔP is more than about 550 Pa, major maintenance is not necessary.

Fig. 32.1 Measuring the differential pressure

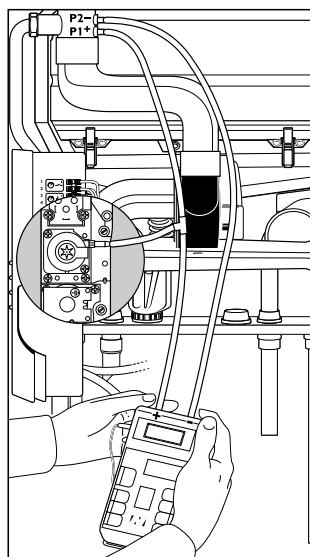

313013

SERVICING

32 SERVICING SCHEDULE (CONT)

Fig. 32.2

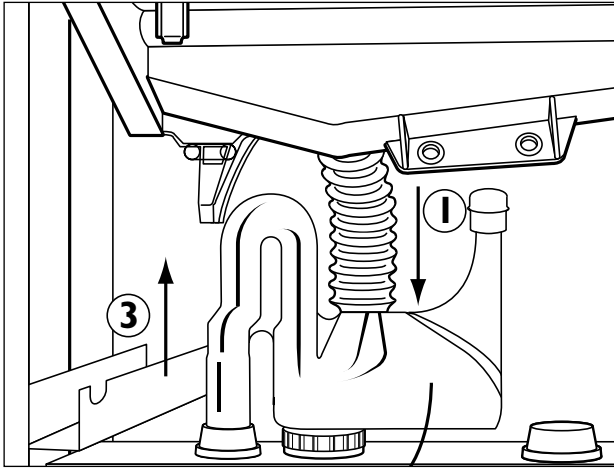

219039

Fig. 32.3 Inspecting the heat exchanger

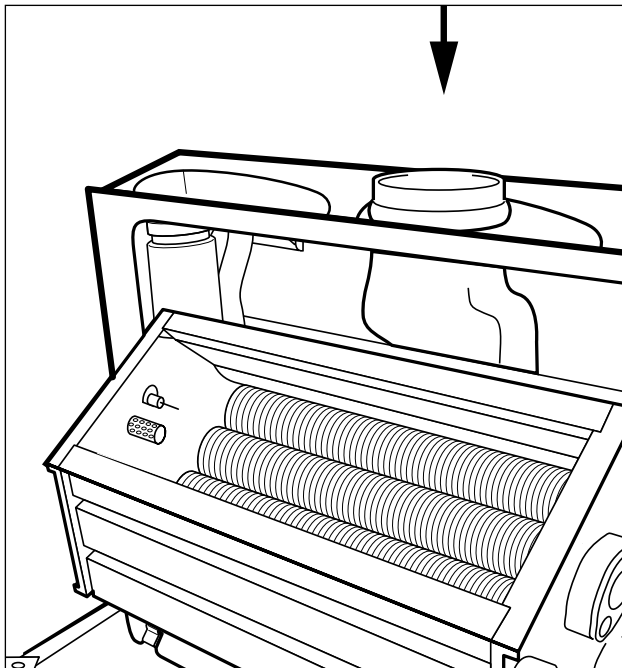

211111

2. Siphon inspection.

Inspecting the siphon of the lower access cover plate in the unit. Remove the siphon located under the lower access cover plate in the unit (refer to Fig. 32.2). The contents of the siphon will indicate whether or not aluminium oxide has been formed. If this is the case, major maintenance should be carried out.

3. Inspecting the heat exchanger.

Remove the burner and the lower access cover plate and inspect the heat exchanger (refer to Fig. 32.3). If the heat exchanger is polluted, major maintenance should be carried out.

Note: *The lower access cover plate has to be cleaned with a steel brush before remounting it. If the seal is dirty, it should be cleaned with a cloth or a soft brush.*

The servicing procedures are covered more fully in Frames 33 to 34 and **MUST** be carried out in sequence.

WARNING. Always turn off the gas supply at the gas service cock, and switch off and disconnect the electricity supply to the appliance before servicing.

IMPORTANT. After completing the servicing or exchange of components always test for gas soundness and carry out functional checks as appropriate.

SERVICING

33 MINOR MAINTENANCE

Fig. 33.1 Preparing the burner detachment

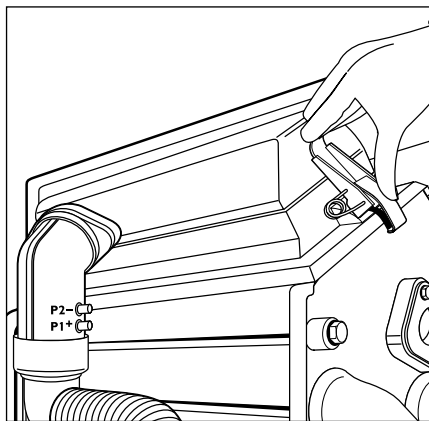

211214

Fig. 33.2 Detaching and cleaning the burner

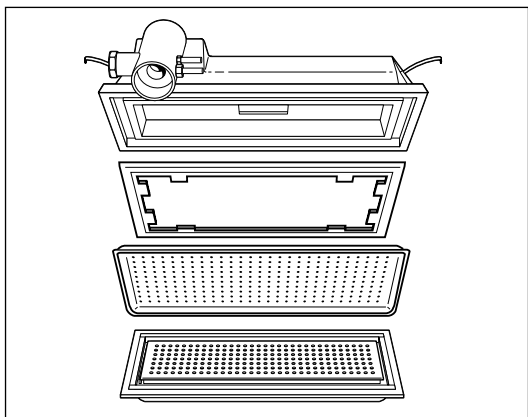

212014 C

Fig. 33.3 Removing the fan

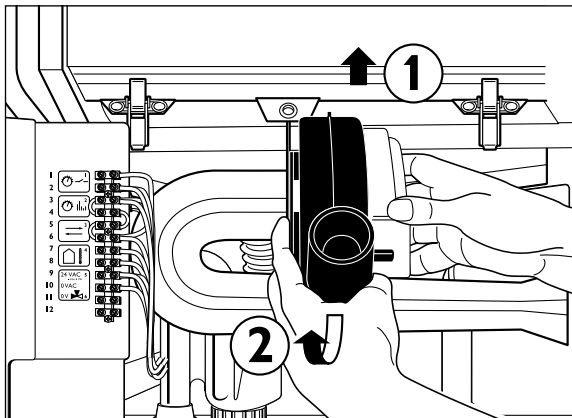

219055

Fig. 33.4 Removing the siphon

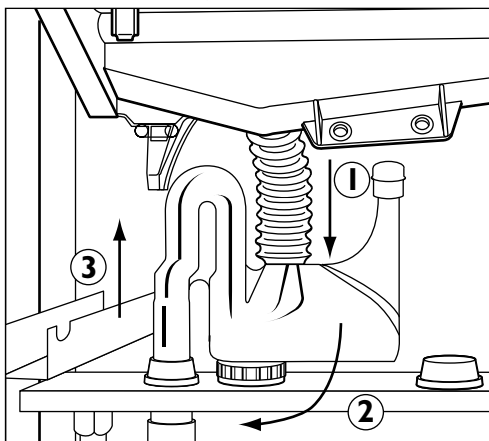

219146

Minor maintenance involves the following activities:

1. Isolate the electricity supply.
2. Successively remove or detach (refer to frame 6):
 - the jacket of the unit (refer to frame 8)
 - the gas pipe from the valve
 - the gas/air pressure pipe
 - the plugs of the burner safety thermostat
 - the air supply hose of the fan.

3. Loosen the two fasteners of the burner. Remove and inspect the burner. If necessary, clean the burner (refer to Fig. 33.2).

Note: the burner cover should be handled with care. Only clean the burner with compressed air or a smooth brush.

4. Inspect the heat exchanger. If the heat exchanger is polluted, major maintenance should be carried out. **Note: If the heat exchanger must be cleaned, the igniter has to be removed. The igniter is very fragile and should never be touched. The igniter is supplied with 120 V-AC. The mains supply MUST therefore always be isolated before removing the burner (dangerous voltage above 50 V-AC).**

5. After cleaning the burner, the silicone burner sealing gasket can be re-used, provided it shows no damage. If it is damaged it should be replaced. Reassemble the burner in reverse order.

6. Remove the fan by loosening it from the lower access cover plate (refer to Fig. 33.3). Inspect and clean the fan, if necessary. In order to remove the fan, disconnect the connecting hose to the burner, remove the green block, and pull the fan towards you.

7. Remove and clean the siphon (refer to Fig. 33.4).

8. After carrying out all the above activities, all parts have to be fitted and the unit put back into operation. The following control measurements and adjustments have to be made:

- Measure the gas/air differential pressure: refer to frame 31.
- Measure the ionisation current: refer to frame 31.

34 MAJOR MAINTENANCE

Fig. 34.1 Removing the lower access cover plate

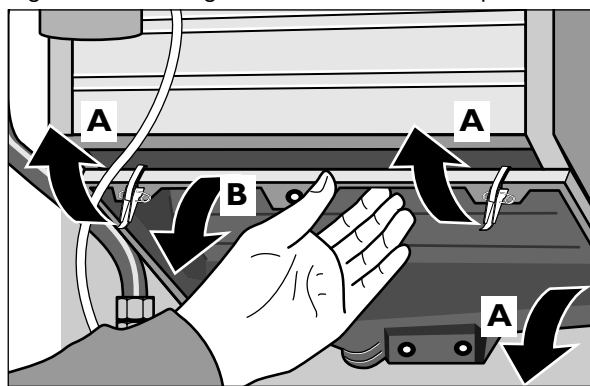

211230

Fig. 34.2 Removing the ionisation electrode

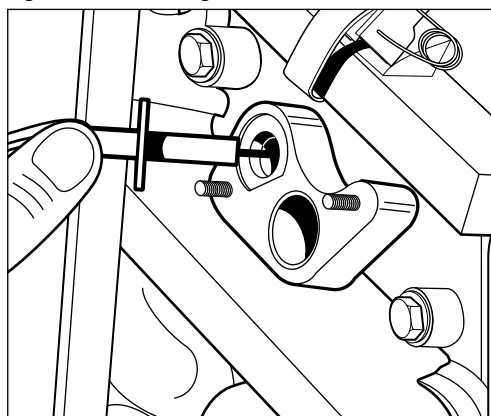

219044

Fig. 34.3 Removing the guide plate

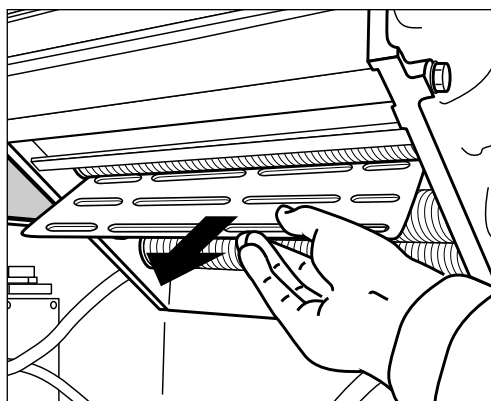

211228

Fig. 34.4 Removing the igniter

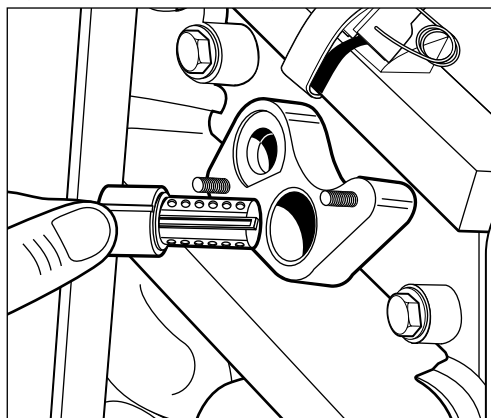

219045

Major maintenance includes all minor maintenance activities. However, major maintenance also includes complete cleaning of the heat exchanger at the combustion gas side: Isolate the electricity supply.

1. Successively remove or detach (refer to frame 6):
 - the jacket of the unit (refer to page 8)
 - the upper union connection on the gas pipe from the gas valve
 - the P1+ hose (control pipe to gas valve)
 - the plugs of the burner safety thermostat
 - the air supply hose of the fan.

2. Loosen the two fasteners of the burner. Remove and inspect the burner. If necessary, clean the burner (refer to frame 33).

Note: the burner cover should be handled with care. Only clean the burner with compressed air or a smooth brush.

4. Inspect the heat exchanger.

4a. Remove the lower access cover plate by detaching the quick-acting closures at the foot of the heat exchanger (refer to Fig. 34.1). Subsequently, clean the cover plate with a steel brush. Clean the gasket with a cloth or a soft brush.

Remove and check:

- the ionisation electrode Fig. 34.2
- the igniter Fig. 34.4 **Note: the igniter is very fragile**
- the guide plate Fig. 34.3

Never touch the igniter directly, it is supplied with 120 V-AC! (Dangerous voltage above 50 V-AC).

At this point, the heat exchanger can be cleaned.

4b. When the cleaning is completed, all parts have to be remounted in reverse order. Mount the guide plate first, mount the igniter next, etc. Make sure all gaskets are also checked.

Continue with activities 5 to 8 described in the minor maintenance procedure (frame 33).

35 replacement of components (REFER TO FRAME 43)

Casing Door (refer to fig. 43.1, key 7)

1. Open the casing door.
2. Carefully continue to hinge the door outwards until the three hinge points become disengaged from the main casing. Remove the door.
3. If necessary, replace the display panel (refer to fig.44.1, pos.12). Refit the door by positioning the hinge points into their sockets and carefully close the door to engage the hinges.

Casing Display Panel (refer to fig. 43.1, key 6)

1. Open the casing door.
2. From the inside of the door unclip display panel from the top and bottom clips nearest the door hinges and remove.
3. Fit new display panel in reverse order.

Casing Seal (refer to fig. 43.1, key 5)

1. Disconnect the electricity supply.
2. Remove the casing assembly and place on a safe working surface (refer to frame 8).
3. Pull the old seal from the casing assembly and discard.
4. Place the new seal in the groove of the casing and press into position taking care that the new seal is not stretched or twisted.
5. Refit the casing assembly to the boiler.

Casing Clamp (refer to fig. 43.1, key 4)

1. Carefully prize open the outer casing from the inner casing at both sides of the clamp.
2. Push the clamp forwards to remove and discard.
3. Fit the new clamp in reverse order.
4. Refit the casing assembly to the boiler.

Burner Thermostat (refer to fig. 43.9, key 56)

1. Disconnect the electricity supply.
2. Remove the casing assembly and place safely to one side.(refer to frame 8)
3. Remove the wires from the two terminals on the thermostat.
4. Unscrew the thermostat and discard.
5. Refit the new thermostat and re-assemble in reverse order.(polarity is not important)
6. Check the operation of the boiler.

Igniter (refer to fig. 43.4, key 35)

1. Follow steps 1-2 of Burner Thermostat replacement.
2. Remove the earth lead from the igniter tab.
3. Remove the two off M6 nuts holding the cover plate.
4. Remove the cover plate and gasket and place safely to one side.
5. Remove igniter and discard.
6. Fit new igniter and reassemble in reverse order.
7. Check the operation of the boiler.

Ionization Electrode (refer to fig. 43.4, key 36)

1. Follow steps 1-4 of Igniter replacement
2. Ensuring the Igniter remains in place, remove the Ionization Electrode, disconnect it's wiring at the connector provided and discard.
3. Reassemble in reverse order taking care not to damage the Igniter.(Very fragile)
4. Check the operation of the boiler.

Fan (refer to fig. 43.6, key 63)

1. Follow steps 1-2 of Burner Thermostat replacement.
2. Swing the control panel away from the fan.
3. Unplug the two electrical connectors from the front of the fan by squeezing the retainers and pulling forwards.
4. If fitted, remove the retaining block from the top fitting point of the fan.
5. Remove the air hose to the heat exchanger by pushing it upward to clear the fan body.
6. Pull fan assembly forwards to clear the rear location points, lower the fan body and push back to clear the front fixing point.
7. Remove the fan assembly and place to one side.
8. Remove three off M6 bolts retaining the Fan Air Inlet Pipe; remove the pipe and bracket. Retain the sealing gasket.
9. Fit the new fan and reassemble in reverse order.
10. Check the operation of the boiler.

Siphon (refer to fig. 33.4 and fig. 43.5, key 41)

1. Follow steps 1-2 of Burner Thermostat replacement.
2. Disconnect the condensate outlet pipe from the siphon lower connection.
3. Disengage the top connection of the siphon from the lower access cover by pulling the siphon body downwards.
4. Fit the new siphon, fill the siphon (see frame 27, para 4) and reassemble in reverse order.
5. Check the operation of the boiler.

Flow/Return/Safety Sensors

(refer to fig. 43.3, key 25 and fig. 43.4, key 39)

1. Follow steps 1-2 of Burner Thermostat replacement.
2. Where possible isolate the boiler from the heating system.
3. Drain the system water from the heat exchanger.
4. Disconnect the sensor at the connector supplied.
5. Unscrew the sensor from the heat exchanger and discard.
6. Fit the new sensor ensuring the 'O' ring is correctly in place and re-connect the wiring.
(Note! The flow sensor is connected to the wiring having the red sleeve attached. If in doubt consult frame 22)
7. Reassemble in reverse order.
8. Refill the system and check the operation of the boiler.

Pump (refer to fig. 43.8, key 89)

1. Follow steps 1-3 of Sensor replacement.
2. Disconnect the electrical leads from the pump.
3. Undo both union connections on the pump and withdraw the pump.
4. Ensure the pipe sealing faces are clean of gasket material, fit the new pump and reassemble in reverse order using new gaskets.(provided)
5. Refill the system and check the operation of the boiler.

Air Purger Valve (refer to fig. 43.3, key 21)

1. Follow steps 1-3 of Sensor replacement.
2. Remove the plastic moulded cover from the top of the back panel.
3. Unscrew and remove the valve retaining nut.
4. With care, withdraw the valve assembly upward through the hole in the back panel.
5. Reassemble in reverse order ensuring the 'O' ring seal is seated correctly on the valve assembly and the moulded cover replaced in the back panel.
6. Refill the system and check the operation of the boiler.

35 replacement of components (REFER TO FRAME 43)

Gas Valve (refer to fig. 43.7, key 72)

1. Follow steps 1-2 of Burner Thermostat replacement.
2. Isolate the gas supply at the nearest gas cock to the boiler.
3. Remove the gas valve outlet pipe by unscrewing the two union nuts holding it to the valve and injector.
4. Remove the gas/air pressure pipe and the electrical connections to the gas valve.
5. Unscrew the union nut under the gas valve and withdraw the valve upward.
6. Unscrew the connectors from the old valve and refit them to the replacement valve using new 'O' rings.(provided)
7. Reassemble in reverse order and set the valve as described in frame 31.
8. Reconnect the gas supply and check the operation of the boiler.

Gas Injector (refer to fig. 43.9, key 57)

1. Follow steps 1-3 of Gas Valve replacement.
2. Unscrew the injector and discard.
3. Fit new injector ensuring the size is correct and the 'O' ring seal is in place.
4. Reassemble in reverse order.
5. Reconnect the gas supply and check the operation of the boiler.

Air Restrictor (refer to fig. 43.9, key 59).

1. Follow steps 1-2 of Burner Thermostat replacement.
2. Swing the control panel away from the fan.
3. Remove the air hose to the heat exchanger by pushing it upward to clear the fan body and then downward to disconnect from the air/gas connecting piece.
4. Remove the air restrictor from the air/gas connecting piece.
5. Fit new restrictor and reassemble in reverse order ensuring the tabs of the restrictor locate into the holes in the air/gas connecting piece.
6. Check the operation of the boiler.

Burner Gasket (refer to fig. 43.9, key 50)

1. Follow steps 1-3 of Gas Valve replacement.
2. Remove the gas/air pressure pipe from the air/gas connecting piece.
3. Remove the air hose to the heat exchanger by pushing it upward to clear the fan body and then downward to disconnect from the air/gas connecting piece.
4. Disconnect the electrical connections to the burner thermostat.
5. Spring open the retaining clips at either end of the burner cover.
6. Remove the burner cover and place to one side.
7. Remove old gasket and discard.
8. Fit new gasket and reassemble in reverse order.
9. Check the operation of the boiler.

Burner Plaque Assembly (refer to fig. 43.9, key 52)

1. Follow steps 1-6 of Burner Gasket replacement.
2. Remove gasket and diffuser plate.
3. Remove plaque assembly and discard.
4. Fit new plaque assembly and reassemble in reverse order.
5. Check the operation of the boiler.

Lower Access Cover Seal (refer to fig. 43.3, key 28)

1. Follow steps 1-7 of Fan replacement.
2. Disconnect siphon from lower access cover plate. (see fig. 33.4)

3. Spring open the upper and lower retaining clips of the lower access cover plate and pull downwards to remove.
4. Remove the damaged seal from the groove in the cover plate and replace with the new seal ensuring it is not stretched or twisted.
5. Reassemble in reverse order and check operation of the boiler.

Heat Exchanger Guide Plate (refer to fig. 43.3, key 31)

1. Follow steps 1-3 of Lower Access Cover Seal replacement.
2. Remove guide plate from heat exchanger and discard.(see fig 43.3)
3. Fit new guide plate and reassemble in reverse order.
4. Check the operation of the boiler.

Sightglass (refer to fig. 43.3, key 22)

1. Follow steps 1-2 of Burner Thermostat replacement.
2. Remove the M6 screws retaining the sightglass assembly.
3. Remove the old sightglass and gaskets and discard.
4. Fit the new sightglass using the new gaskets provided.
5. Reassemble in reverse order and check operation of the boiler.

Main Switch (refer to fig. 43.2, key 105)

1. Follow steps 1-2 of Burner Thermostat replacement.
2. From behind the control panel, push the black tab to disengage the main switch.
3. From the front of the control panel, remove the switch from its electrical connections.
4. Fit the new switch and push the assembly back into the control panel.
5. Reassemble in reverse order and check the operation of the boiler.

Temperature/Pressure Gauge (refer to fig. 43.2, key 104)

1. Follow steps 1-2 of Burner Thermostat replacement.
2. De-route the temperature and pressure sensing capillaries from the flow pipe to the control panel.
3. From behind the control panel, unscrew the clamp nut and remove the clamp.
4. Remove the gauge from the front of the control panel and discard.
5. Fit the new gauge and reassemble in reverse order.
6. Check the operation of the boiler.

UBA or Control panel (refer to fig. 43.2, key 99)

1. Follow steps 1-2 of Burner Thermostat replacement.
2. Remove all electrical connections from the rear of the UBA.
3. Remove the main switch from the UBA (see Main Switch replacement).
4. From the front of the control panel remove upper and lower fixing screws and remove the UBA.
5. Fit the new UBA and fix with screws.
6. Cut rectangular hole in fascia to accept the main switch.
7. Refit main switch and replace all electrical connections.
8. Reassemble in reverse order and check the operation of the boiler.

35 replacement of components (REFER TO FRAME 43) (CONT)

Heat Exchanger (refer to fig. 43.3, key 19)

1. Disconnect the electricity supply.
2. Where possible isolate the boiler from the heating system.
3. Drain the system water from the heat exchanger.
4. Isolate the gas supply at the nearest gas cock to the boiler.

Remove the components listed below by following the instructions for their removal previously stated in these instructions.

- * Casing complete
- * Igniter
- * Ionization Electrode
- * Fan
- * Flow/Return/Safety Sensors
- * Pump
- * Burner Plaque Assembly
- * Lower Access Cover
- * Heat Exchanger Guide Plate

5. Disconnect the flue system from the boiler and remove the adapter plate fixed to the back panel.
6. Remove the clip holding the heat exchanger to the flow pipe.
7. Lift the heat exchanger from its hooks in the back panel and remove to a safe working surface.
8. Remove the fixing screws holding the flue outlet pipe to the heat exchanger and remove the pipe.
9. Refit the flue pipe to the new heat exchanger and secure with the existing fixings.
10. Refit the heat exchanger to the back panel securing it on the hooks provided.
11. Reassemble all components in reverse order.
12. Refill the system, reconnect the electricity and gas supplies and check the operation of the boiler.

FAULT FINDING

36 CONTROL PANEL DISPLAY

Fig. 36.1 Display and service code

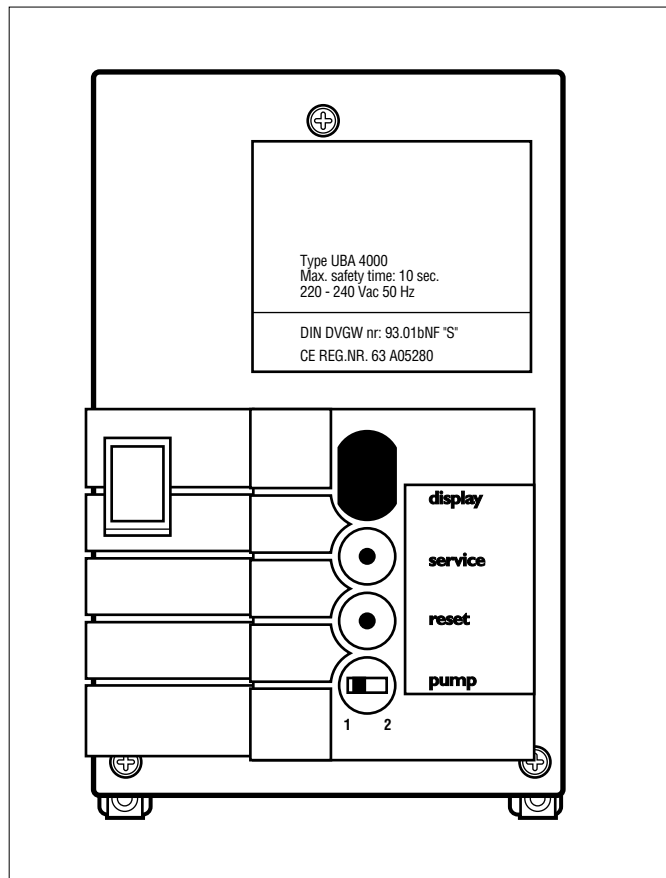

211077

Operating functions

General explanation display and service codes

The current operating condition of the unit is indicated by a display code and a LED, located on the control panel. By pressing the service button, a second code will appear. The combination of both codes gives detailed information about the operating condition of the unit.

The indicated display code corresponds with the operating functions described below:

display code	operating function
0	Stand-by
-.	Central heating operation
=.	Hot water
1	FGD/burner thermostat
2	Water circuit
4	Water temperature
5	Communication
6	Ionisation
7	Mains voltage
8	Gas circuit
9	System
E	Control system

During operation of the Maximiser SE condensing boiler the status of the appliance can be determined by the display.

1. Normal operation.

The display will remain constant. The unit either on stand by or in operation. The meaning of the code can be determined from the information in frame 36.

2. Fault condition.

The display will flash on and off. The unit will be inoperative and the display will provide codes which should be noted down and compared with the listings in frames 37 to 41.

37 FAULT FINDING

During normal operation (no fault having occurred) one of the following codes with the corresponding service code, will be

indicated on the display panel of the Maximiser SE condensing boiler.

display code	service code	unit operating condition
P		Starting up the Control panel sequence
r		Restart of the Control panel sequence after a reset
c		Control panel sequence checks the unit data when starting up
d		Control panel sequence reads the unit data
0	A	Anti fast-cycle program in operation
0	H	Unit is stand-by; no heat required
0	L	Unit is in ignition phase
0	U	15 seconds ventilation phase before or after operation of the unit
0	Y	Water temperature higher than adjusted, unit is waiting
-.	H	Unit is in operation for central heating
2	F	This code can appear if the unit adjusts itself to the small amount of water in the installation.
=.	H	Unit is in operation for hot water

38 FUSE SPECIFICATION

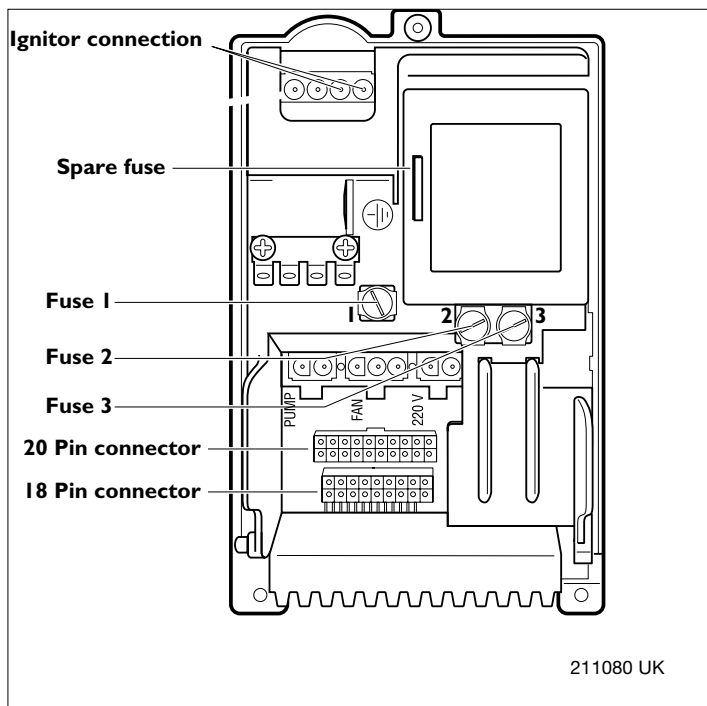

Glass fuse position

F1 fuse = igniter, 1.25 A slow, 250 V,

F2 fuse = burner thermostat and control panel, 1.25 A slow, 250 V,

F3 fuse = three-way valve and control panel, 1.25 A slow, 250 V,

211080 UK

39 FAULT DIAGNOSIS

By combining the display and service codes that are shown with the unit and/or installation behaviour, the cause of the malfunction can be found. Normally, the operating code is indicated on the display. By pressing the "Service" button, the service code will appear. In the following table the most

important combinations of codes and boiler behaviour are shown. The numbers listed in the "causes" column refer to frame 41. This table shows you how to find the cause of the malfunction and how to solve the malfunction.

FAULT FINDING

40 FAULT FINDING - CODES			
Display code	Service code	Unit and/or installation behaviour	Causes
0 or =.	H	The central heating installation is not heated, but the hot water tank (if present) is.	1
-.	A	The central heating installation is overheated; the hot water tank is not heated.	1
-.	Y	Unit is constantly fired for the central heating and does not modulate in reverse direction. The central heating installation is overheated or not sufficiently heated; the hot water tank is not heated. Unit is constantly operative for the central heating, at the capacity adjusted with the hot water potentiometer.	1
0 or -.	H	The central heating installation is correctly heated, but the hot water tank (if present) is not.	3
-.	H	The central heating installation is not sufficiently heated, the hot water tank (if present) is correctly heated. On the central heating side the unit can only be fired at low power.	12,17,18,20
=.	H	Demand of large quantities of hot water from the tank causes a decrease in temperature or the hot water flow is too small.	18,43
=.	H	The central heating installation is overheated, the hot water tank (if present) is not heated.	5
=.	H	The central heating installation gets overheated as soon as the hot water tank requires heat.	6
0 or -.	H	The central heating installation is overheated, the hot water tank (if present) is correctly heated.	2
0	Y	The unit switches off at the central heating side or feeds back power on the supply sensor. The central heating installation is not heated, the hot water tank (if present) is overheated.	4
0	Y	The unit is controlled with the return sensor. Neither the central heating installation nor the hot water tank (if present) are heated.	14
0	Y	The central heating installation is not sufficiently heated. The central heating water temperature is higher than the set value.	9
0	A	Unit in anti fast-cycle time.	7
1	C	Connection for flue gas thermostat not closed.	44
2	C	Safety sensor of the heat exchanger is overheated.	10/13/15/16
2	F	The difference in heat between the safety sensor and the supply sensor is too large or the supply and return sensor have been interchanged.	10/13/14/15/16
2	P	Temperature of safety sensor is rising too fast.	12/13/42
2	U	Temperature difference between the supply sensor and return sensor too large.	10/15/20
4	A	Temperature supply sensor too high (> 101 °C).	14/15/16
4	C	Fuse F2 blown or temperature of burner thermostat too high or supply temperature too high.	22/21
4	F	Temperature safety sensor above 101 °C.	13/15/16
4	L	Safety sensor short-circuited.	8/23
4	P	Safety sensor not connected.	8/24
4	U	Supply sensor short-circuited.	8/23
4	Y	Supply sensor not connected.	8/24
5	A	Control panel locked.	32
5	Y	Control panel locked.	32
6	A	No ionisation after ignition phase, defective igniter.	25
6	A	No ionisation after ignition phase, fan is not rotating.	19/35
6	A	No ionisation after ignition phase, igniter and fan are functioning.	26/27/28/29/33
6	C	Ionisation occurs when heat is no longer required, the gas valve does not close.	34
6	H	The ionisation (the flame) directly extinguishes after ignition.	26/28/29/33
6	L	The ionisation (the flame) extinguishes during operation of the unit.	26/28/29/32
7	A	Defective control panel.	39
<p>Display code = normally visible Service code = visible after pressing the service code button</p>			

40 FAULT FINDING - CODES (CONT)			
Display code	Service code	Unit and/or installation behaviour	Causes
7	C	Mains supply failure during locking error or reset button released too soon.	30/32
7	F	Defective control panel or blown F3 fuse.	31/39
7	H	Defective control panel.	39
7	L	Defective control panel.	39
8	L	Defective cable connection.	33/36
9	A	Defective control panel.	39
9	C	Control panel not able to detect BIM.	37
9	F	Failure regarding to control panel reference temperature.	41
9	H	Internal failure control panel.	41
9	L	Improper electrical connection of gas control combination or defective control panel.	38/39
9	P	Internal failure control panel or defective ModuLine.	39
9	U	Control panel not able to read BIM.	37
E	A	Defective control panel.	39
E	C	Defective control panel.	39
E	F	Defective control panel.	39
E	H	Defective control panel.	39
E	P	Control panel and BIM not compatible.	37/39
E	L	Defective control panel.	39
No display		No mains supply or defective control panel.	39/40
<p>Display code = normally visible Service code = visible after pressing the service code button</p>			

41 FAULT FINDING - CAUSES	
Malfunction causes and remedies	
<p>The table shown below gives the possible cause of the malfunction described in frame 40. The table also provides instructions of how to remedy the malfunction.</p>	
Cause No.	Cause description
1	The room thermostat is not properly connected; ensure a proper connection of the poles!
2	The room thermostat does not switch off. Defective thermostat or wiring.
3	The hot water tank sensor is short-circuited or defective.
4	The hot water tank sensor is disconnected: loose contact or wire cut.
5	The three-way valve does not revolve: loose contact in cable connections or in valve connector.
6	A leakage in the three-way valve has occurred because of contamination and/or wear or the three-way valve is not properly connected (at the central heating side).
7	The room thermostat is incorrectly set (anticipation resistance) or there is a loose contact in the room thermostat (on/off thermostat) or in the connecting wires.
8	Sensor is defective or not connected.
9	The central heating potentiometer on the control panel is set at an insufficient value (in case of an on/off control) or the IRT (Intelligent Room Thermostat) is incorrectly set (mod. thermostat).

FAULT FINDING

41 FAULT FINDING - CAUSES (CONT)

Malfunction causes and remedies

The table shown below gives the possible cause of the malfunction described in frame 40. The table also provides instructions of how to remedy the malfunction.

Cause No.	Cause description
10	Too high resistance in the central heating circuit, e.g. because of blocked thermostatic radiator valves or because of blockage by dirt.
11	The test switch on the control panel is switched on; put it back in off position.
12	Too few radiators are open or the differential pressure switch is not properly adjusted.
13	Defective safety sensor.
14	Defective/polluted supply sensor.
15	The pump is dead; loose contact in the connecting wires or the plug is incorrectly mounted in the control panel. Pump stuck or defective.
16	Water level is too low in the central heating system because of a leakage or because of air in the installation. Check the pressure gauge, eventually fill up to 2 bar and open the air separator one full turn (provided that it was closed).
17	The 11 kW jumper has been removed from the control panel or the partial load potentiometer is set at an insufficient value. If the fan only operates at low speed, the fan or control panel is defect.
18	Too much resistance or dirt in the air circuit; check the air supply/combustion gas discharge system, the burner, and the heat exchanger.
19	The fan is not functioning properly; check the connectors and the fuse of the transformer and check the voltage on the control panel connector.
20	Return sensor is defective or not properly connected.
21	Burner thermostat is open or not connected; check the thermostat for the switching point 107°C. Check the burner cover for defects, it is possible that the flame will extend to the rear-side of the burner cover. Check the sealing between the mixing chamber and the heat exchanger and check the connection of the burner housing to the heat exchanger.
22	The fuse F2 in the control panel is blown, caused by a short-circuit in the gas valve-circuit. Check the electrical connection of the gas valve for a proper functioning.
23	Disconnect the connector of the sensor and press "reset". When the same fault remains, short-circuiting in the cable loom has occurred or the control panel is defect, otherwise the sensor is defect.
24	Sensor defect or improper contacts and connections.
25	The connecting wires of the igniter do not make contact or the igniter is defective or the fuse F1 is defective. Control panel should supply 120 V to connector.
26	Improper gas/air ratio. Check the air restriction and the gas injector for the correct diameter, mounting, and pollution.
27	The first and/or second gas valve does not open, check for a 24 V supply during the ignition phase. Check the resistance of the burner thermostat (unit electrically disconnected) maximum resistance of 3Ω.
28	The burner is supplied with too little gas or air is present in the gas pipe; check the pre-pressure. If the control pipe is not blocked, the gas/air ΔP should be checked at minimum and maximum load.
29	Check the connection of the ionisation pin, use the pin to measure the ionisation current in series (this current should amount to at least 2 μAC).
30	Check the mains supply during operation.
31	Short-circuiting in the 24 V circuit (three-way valve or connector); check for a short-circuit and replace the F3 fuse in the control panel.
32	Press "reset" until "r" appears on the display.
33	Gas inlet-pressure too low; check the inlet-pressure during operation at maximum load. Inlet-pressure should amount to at least 20 mbar (25 mbar -17%).
34	Gas valves do not close; check the voltage on the gas valve. If a voltage is measured on both the gas valves (> 20 V), the control panel should be replaced. When ionisation occurs while the unit is not operational, the ionisation circuit should be checked. If the control panel and the ionisation function properly, the gas valve has to be replaced.

41 FAULT FINDING - CAUSES (CONT)

Malfunction causes and remedies

The table shown below gives the possible cause of the malfunction described in frame 40. The table also provides instructions of how to remedy the malfunction.

Cause No.	Cause description
35	BIM is defective or not properly connected, when started, the fan will rotate for a moment and then stops.
36	Gas pressure detector (if present) is defective or the wires have not been properly connected.
37	BIM is defective or not properly connected (contact Ideal Care Technical helpline).
38	Check the electrical connections of the gas valve.
39	Check the ModuLine room thermostat. If the thermostat functions properly, the control panel is defective. Replace the control panel.
40	Check the mains supply.
41	Replace the control panel if the malfunction remains after a reset or if the malfunction has occurred before at this control panel.
42	The hot water tank is too small for this unit power (external hot water tank).
43	The flow limiter is not properly adjusted.
44	Electrical connection in cable loom (red / red-brown) disconnected. Flue gas thermostat (option) is activated or is defective.

42 SHORT LIST OF PARTS

The following are parts commonly required as replacements, due to damage or expendability. Their failure or absence is likely to affect the safety and/or performance of this appliance.

The full list is held by **Caradon Ideal** distributors and merchants.

When ordering spares please quote:

1. Boiler model.
2. Description
3. Quantity.

Key No.	G.C. No.	Description	Quantity	Product No.
1	E58-941	Casing	1	075627
3	E58-954	Casing clamp left side	2	075606
4	E58-952	Casing clamp right side	2	075600
5	E58-956	Casing seal	1	075607
6	E58-942	Casing display	1	075628
7	E58-940	Casing door	1	075626
25	E59-021	Sensor NTC 10 kΩ incl. o-ring 075363	2	075560
28	E59-041	Lower Access Cover Seal (SE 42)	1	075608
-	E59-195	Lower Access Cover Seal (SE 65)	1	075730
30	E59-044	Mounting clip, lower access cover/burner housing	1	075616
35	E59-018	Igniter	1	075558
36	E59-020	Ionisation Electrode	1	075559
39	E59-033	Safety sensor NTC 10 kΩ incl. o-ring 075363	1	075586
41	E58-962	Syphon incl. seal 075604	1	075574
50	E59-008	Burner sealing gasket (SE42)	1	075610
-	E59-215	Burner sealing gasket (SE65)	1	075721
52	E59-000	Burner Plaque Assembly (SE42)	1	075571
-	E59-705	Burner Plaque Assembly (SE65)	1	075720
56	E59-005	Burner thermostat 107°C	1	075618
63	E59-058	Fan (SE 42)	1	075585
-	E59-722	Fan (SE 65)	1	170838
72	E58-998	Gas valve incl. 2x conn. nipple 075579, 2x o-ring 075553 (SE42)	1	075580
73	E59-737	Gas valve incl. 2x conn. nipple 075579, 2x o-ring 075553 (SE65)	1	075718
89	E58-993	Pump UP 25-55 incl. 2x gasket 075552	1	075620
99	E59-010	Control panel excluding on/off switch	1	075561
104	E59-016	Temperature/pressure guage + capillary RD52	1	075623
105	E59-012	Mains switch	1	075631

43 Casing / Control panel

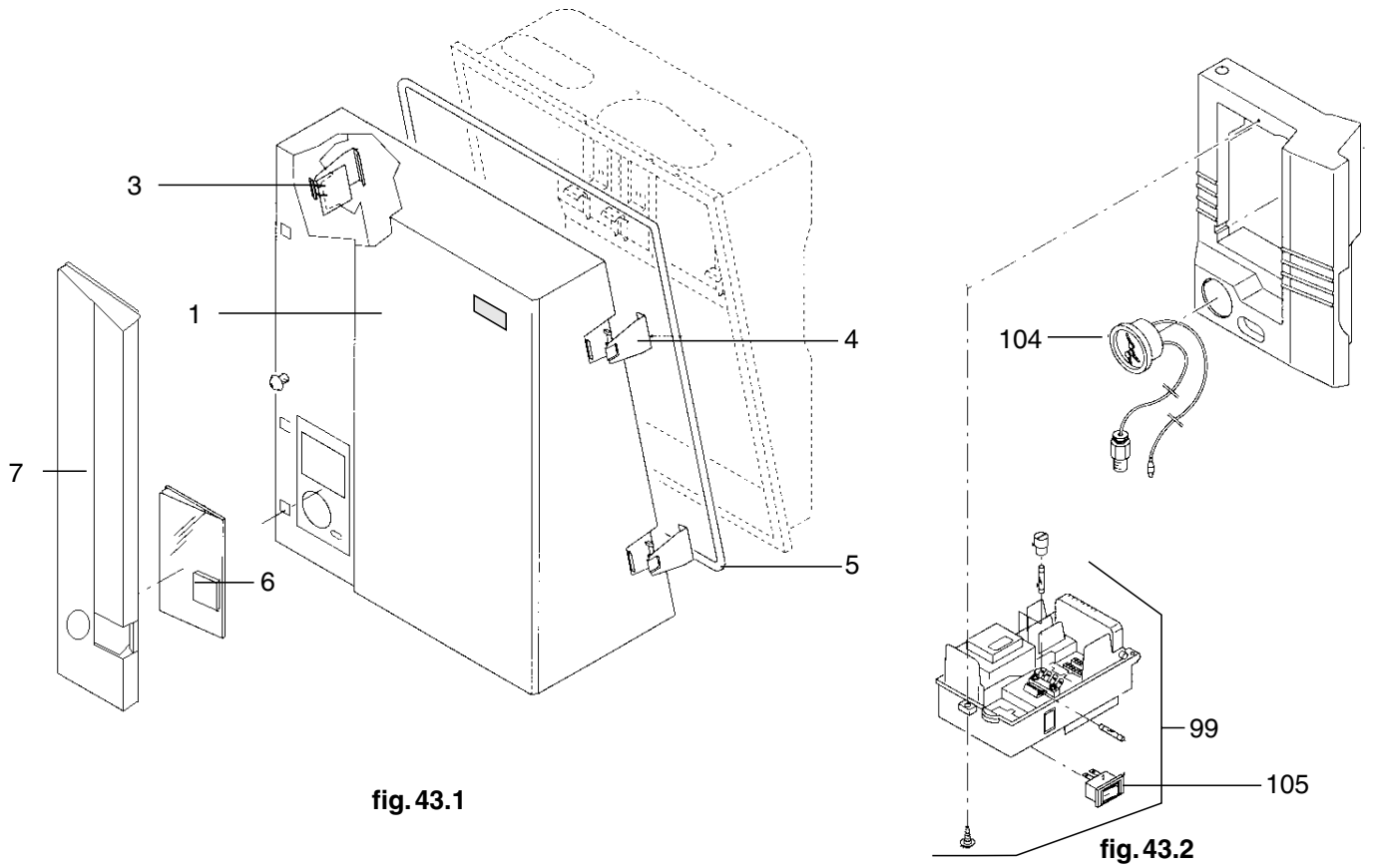

fig. 43.1

fig. 43.2

43 Heat exchanger

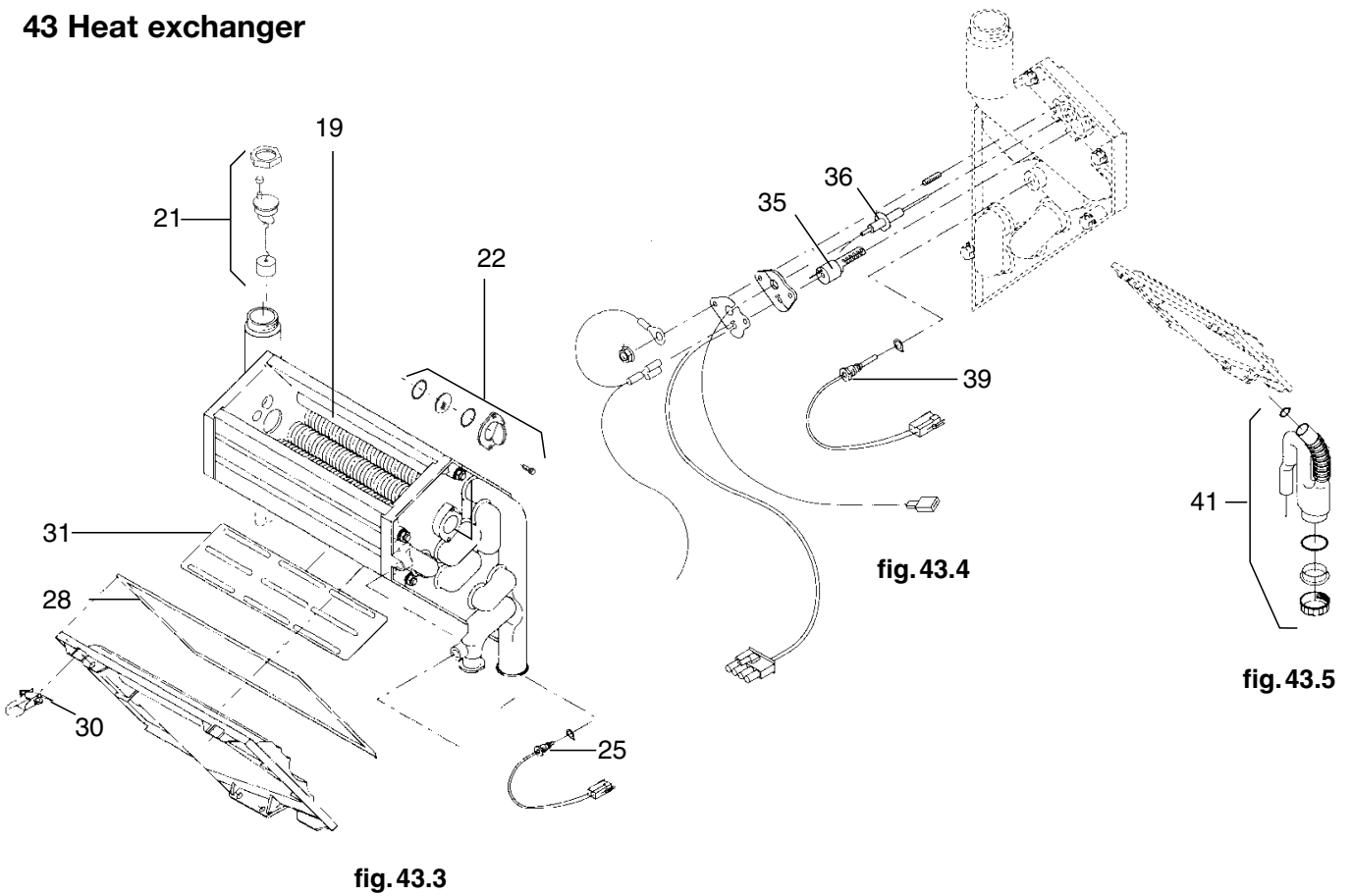
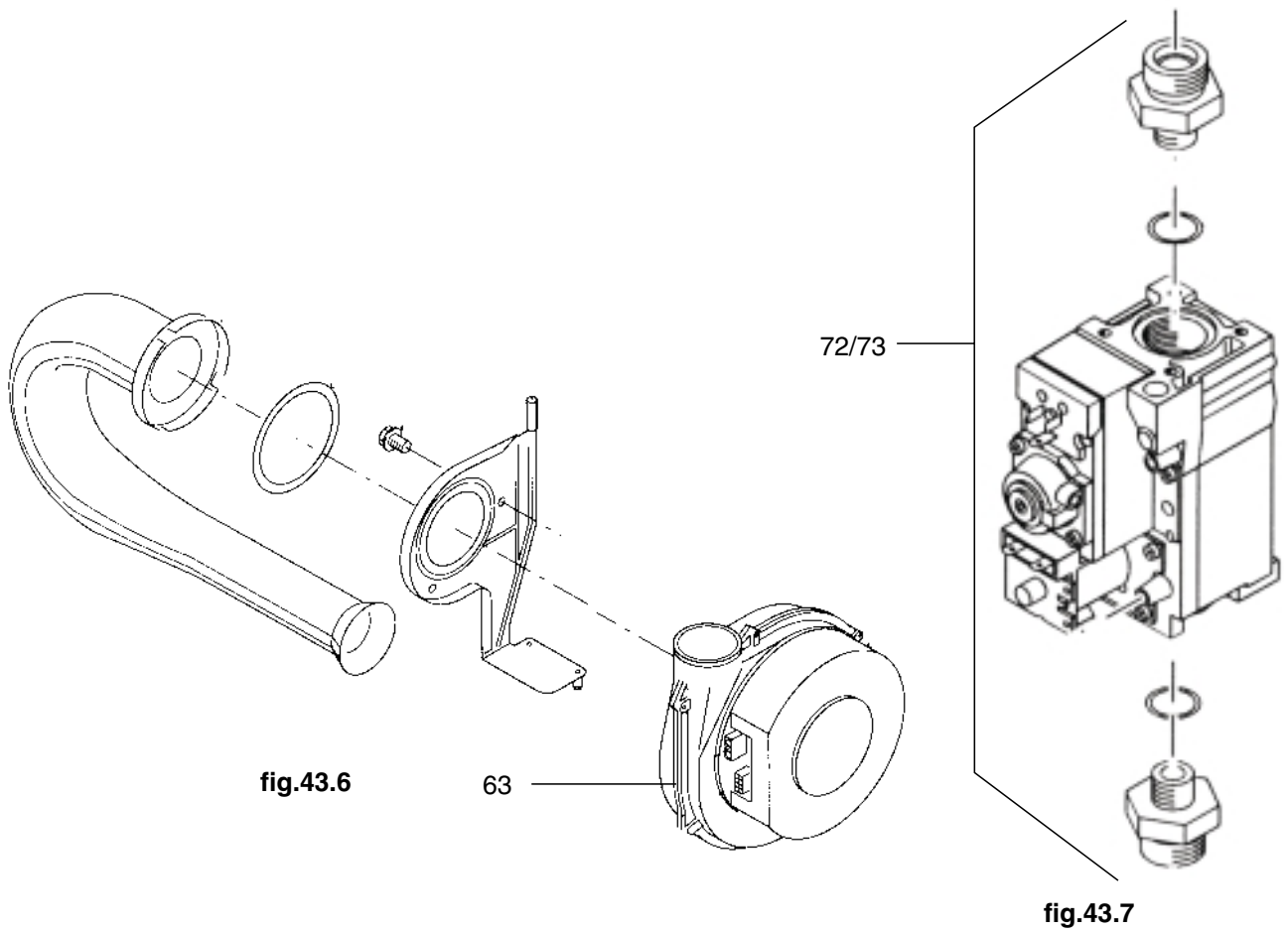

fig. 43.3

fig. 43.4

fig. 43.5

43 Fan / Gas control



43 Pump / Burner

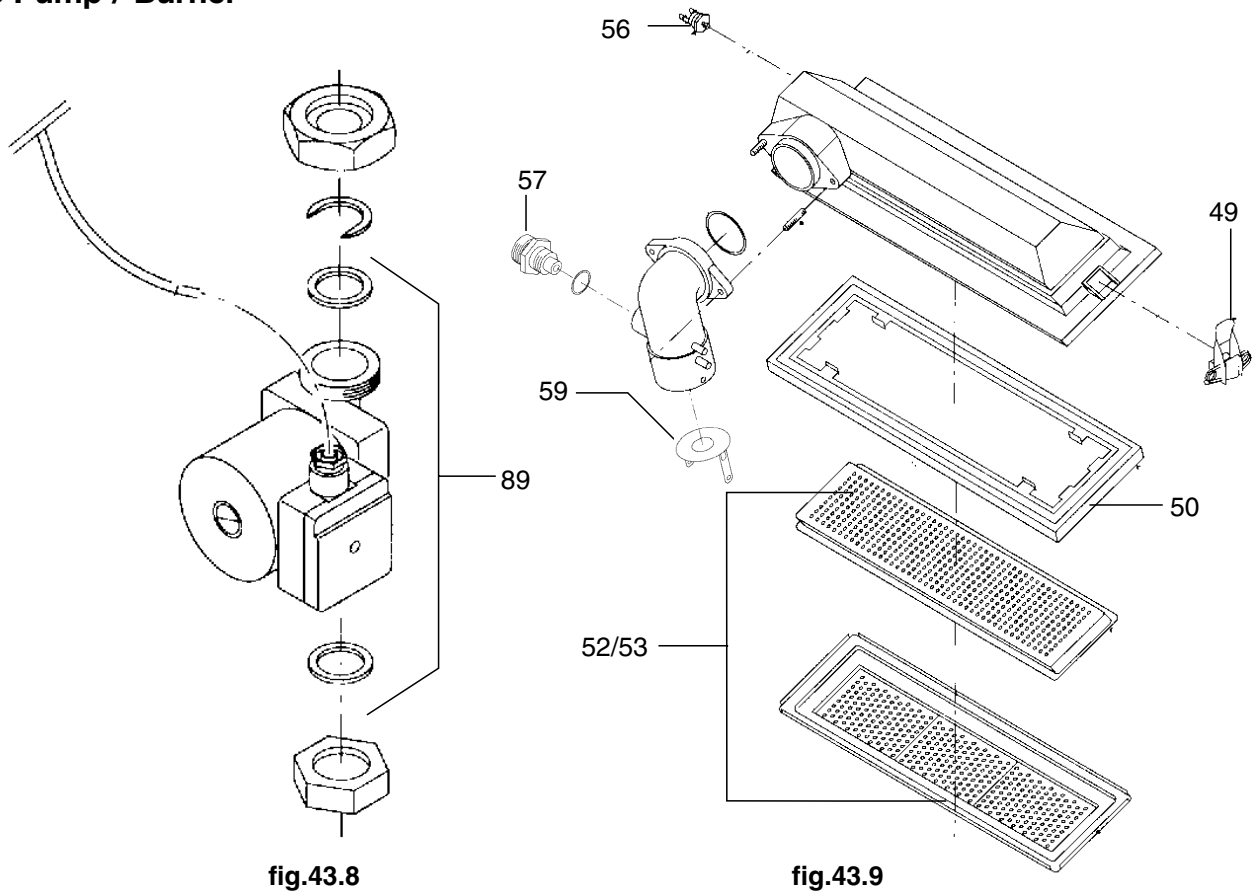

Technical Training

The Caradon Plumbing Solutions Technical Training Centre offers a series of first class training courses for domestic, commercial and industrial heating installers, engineers and system specifiers. For details of courses please ring:

.....01482 498432

PO Box 103
National Avenue
Kingston upon Hull
HU5 4JN
Telephone 01482 492251
Facsimile 01482 448858

Registration No. London 322137
Registered Office
National Avenue
Kingston upon Hull
HU5 4JN

A subsidiary of Caradon plc

Ideal Care Helpline: 01482 498603

Caradon Plumbing Solutions

pursues a policy of continuing improvement in the design and performance of its products. The right is therefore reserved to vary specification without notice.

152556 AO



819015

705.460A 3233 10-2000

Caradon 
Plumbing Solutions

819043