



CONVERSION KIT NATURAL GAS TO PROPANE

**IMAX XTRA 2
80 120 160 200 240**

When replacing any part on this appliance, use only spare parts that you can be assured conform to the safety and performance specification that we require. Do not use reconditioned or copy parts that have not been clearly authorised by Ideal Heating.

For the very latest copy of literature for specification and maintenance practices visit our website idealheating.com where you can download the relevant information in PDF format.



INTRODUCTION

The kits can be applied to the boilers as per the table below.

NOTE: Boilers that have CAT. II_{2H3P} included on the boiler data badge can be converted from natural gas to propane and vice versa using a model specific conversion kit.

Boilers that show CAT. I on the data badge cannot be converted.

kW (NG)	Product No.
Imax Xtra 2 80	225464
Imax Xtra 2 120	225465
Imax Xtra 2 160	225466
Imax Xtra 2 200	225467
Imax Xtra 2 240	225468

NOTE: Screen displays shown in this manual are correct at date of issue. Software updates installed after the date of issue may result in minor changes to screen displays.

Current Gas Safety (Installation & Use) Regulations or rules in force MUST be adhered to. It is law that all gas appliances are installed and serviced by a Gas Safe Registered Installer or in IE a competent person, in accordance with the regulations. Failure to install appliances correctly could lead to prosecution. It is in your own interest, and that of safety, to ensure the law is complied with.

WARNING

ALWAYS TURN OFF THE GAS SUPPLY AT THE GAS SERVICE COCK, AND SWITCH OFF AND DISCONNECT THE ELECTRICITY SUPPLY TO THE APPLIANCE AND ANY EXTERNAL CONTROLS BEFORE SERVICING OR REPLACING COMPONENTS.

KIT CONTENTS

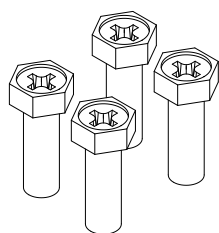

A

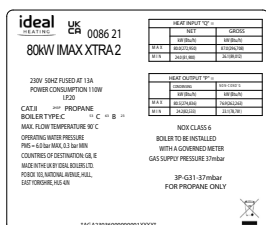

B

80 kW shown

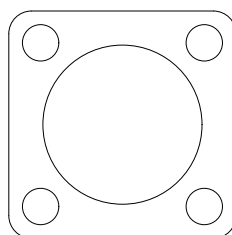

C

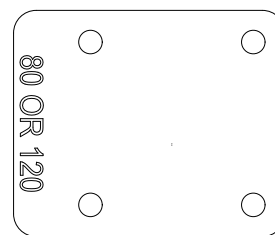

D

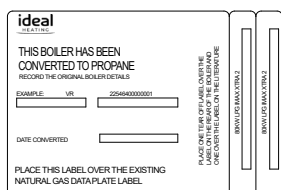

E

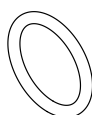

F

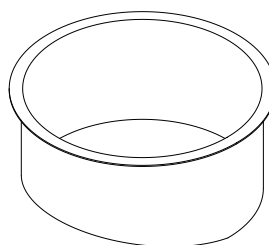

G

200 kW only

LEGEND

- A. 4 off - M5 x15 mm bolts
- B. Self adhesive propane data plate
- C. Orifice plate seal
- D. Orifice plate (see table)
- E. Overlay label
- F. O-ring
- G. Flue Adaptor (200 kW only)

80 kW	9 mm
120 kW	9 mm
160 kW	10 mm
200 kW	11.5 mm
240 kW	12 mm

SAFETY

It is the law that any service work must be carried out by a Suitably qualified Gas Safe Registered Engineer. In IE service work must be carried out by a competent person.

WARNING

ALWAYS TURN OFF THE GAS SUPPLY AT THE GAS SERVICE COCK, AND SWITCH OFF AND DISCONNECT THE ELECTRICITY SUPPLY TO THE APPLIANCE AND ANY EXTERNAL CONTROLS BEFORE SERVICING OR REPLACING COMPONENTS.

IMPORTANT

After completing the servicing or replacement of components always:

- Test for gas soundness.
- Check the water system is correctly filled and free of air. Air in the boiler could cause damage to the heat exchanger.
- With the system hot examine all water connections for soundness.
- Check the gas rate and measure the combustion CO/CO₂ content. The CO/CO₂ ratio of the flue gas should not be greater than 0.004 ratio & the CO should not exceed 350ppm.
- Carry out functional checks as appropriate.

CASING REMOVAL AND ACCESS

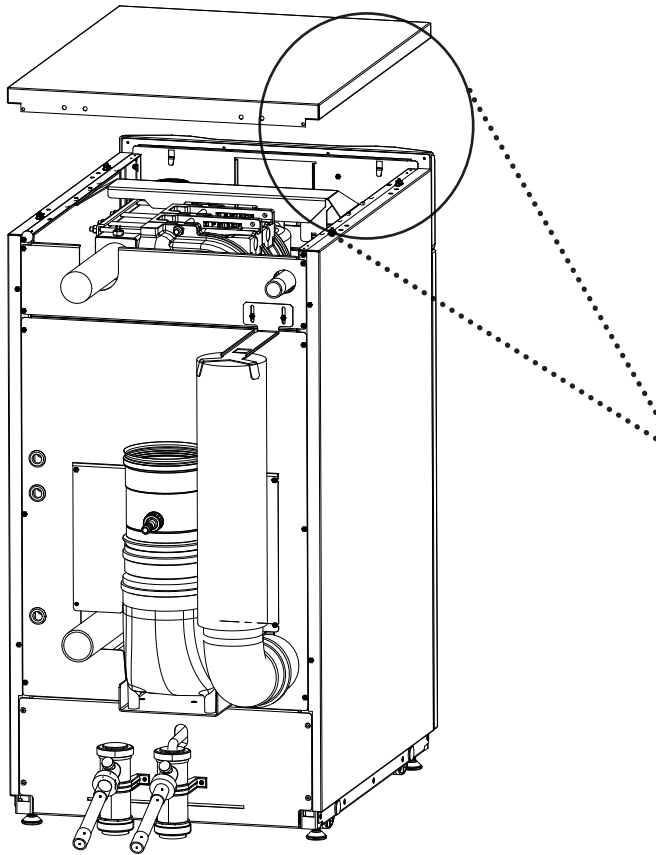

Top Panel

1. Remove the two bolts at the rear of the top panel. Lift up from side panel retention studs and remove.

Control Pod

2. Remove the bolt at the rear of the control pod. Disconnect the electrical harnesses from the rear. Lift the pod up and remove.

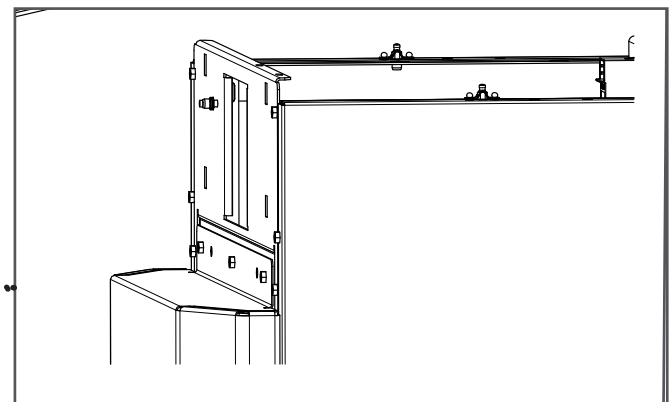
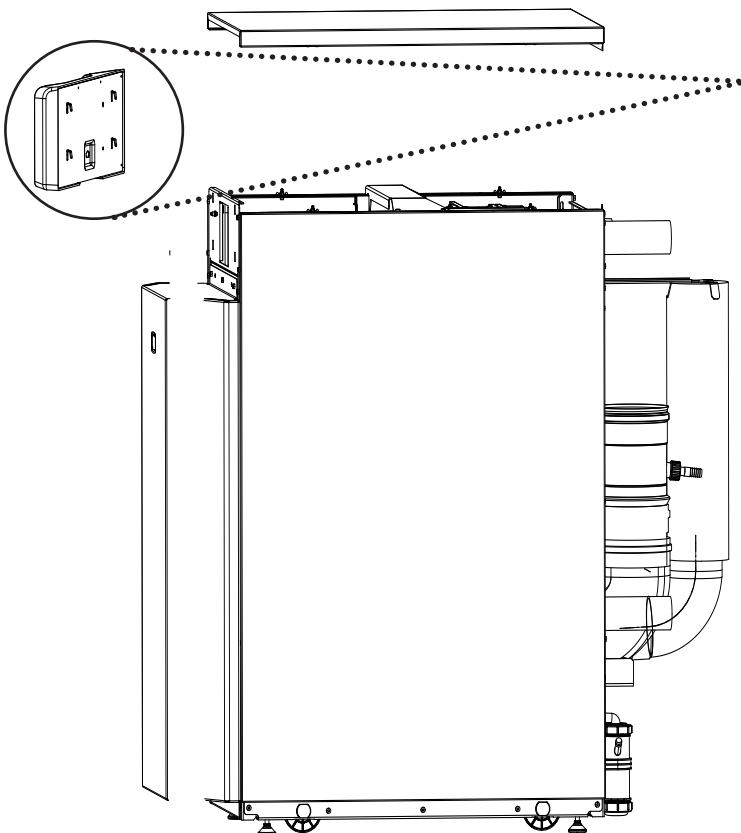
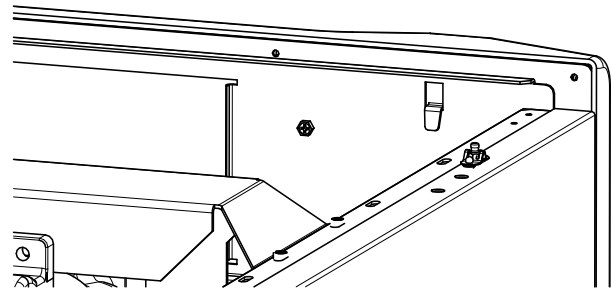

Front Panel

3. Remove the 3 bolts along the top of the front panel. The bolts are visible when the control pod is removed. Pull the panel forwards at the top, lift out of bottom slot and remove.

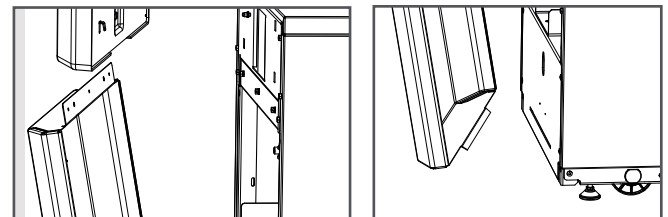

Side Panels

4. On the side panel, undo the two screws at the rear and two at the front. Lift from the frame and remove.

INSTALLING THE ORIFICE PLATE

1. Whilst supporting the gas valve, remove the four bolts securing the gas valve to the venturi.
3. The orifice plate should be orientated so that the etching on the plate is facing the venturi and is visible. See views below for correct orientation.

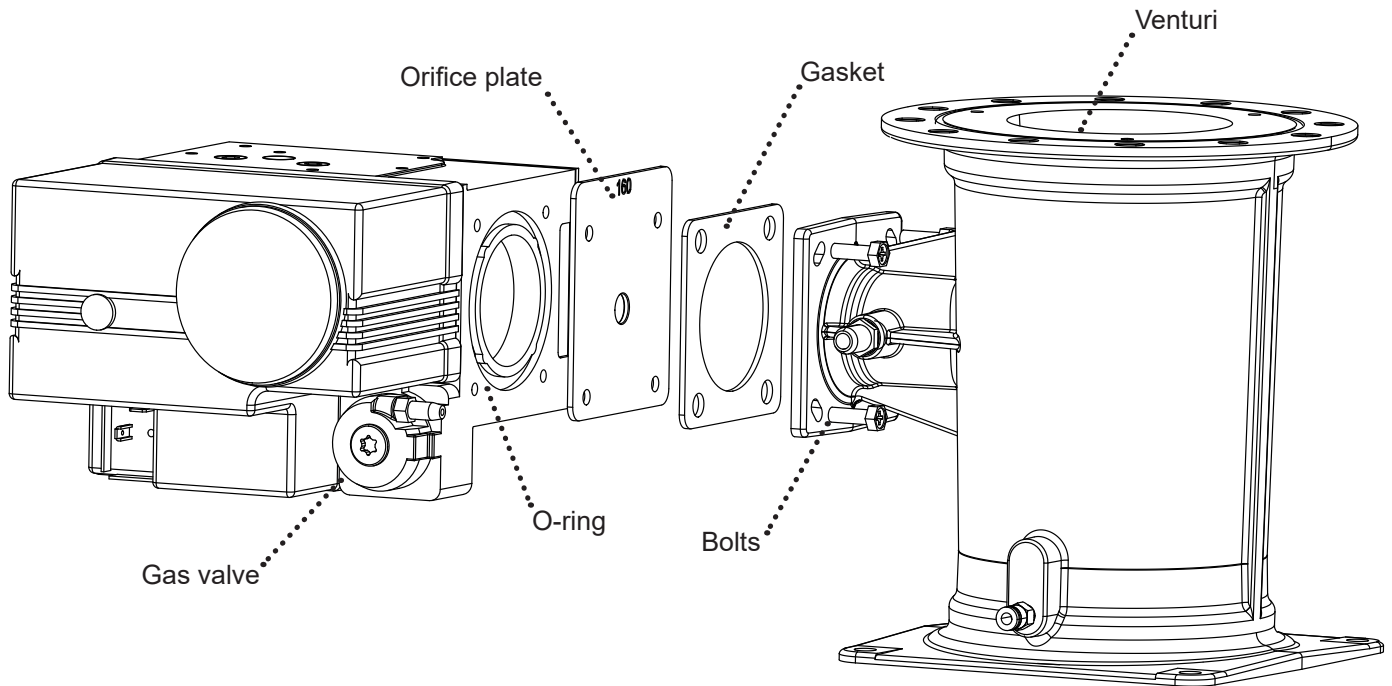

2. Insert the gasket and orifice plate in the order as shown in the exploded view above. Replace the existing O-ring on the gas valve side with the new O-ring supplied in the conversion kit and ensure it is secure.
4. Replace the four bolts that have been removed with the four new M5 x 15mm bolts supplied in the conversion kit. Ensure an even tightening sequence of the bolts.

Orientation of Orifice Plate

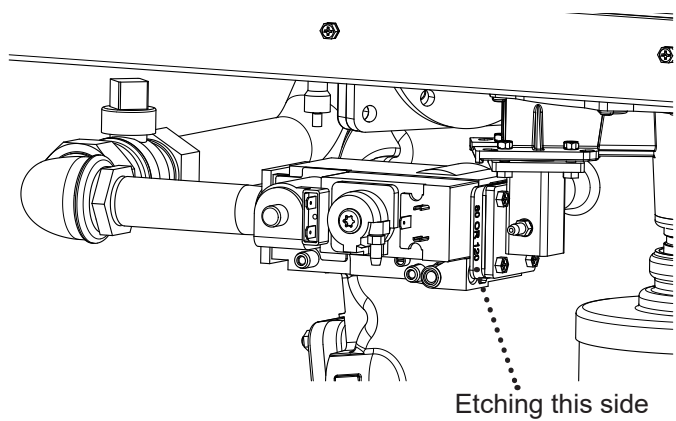

MODELS: 80 kW & 120 kW

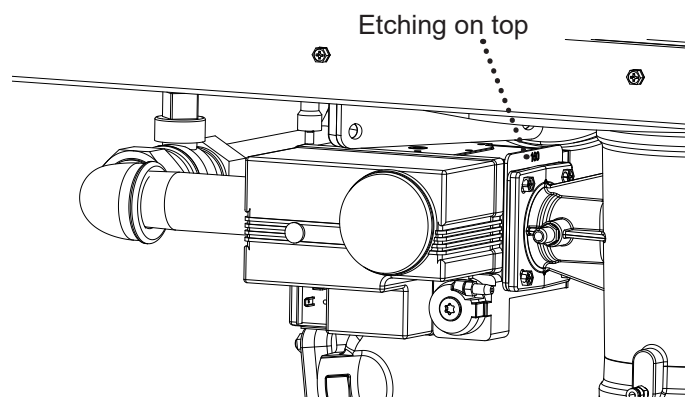

MODELS: 160 kW, 200 kW & 240 kW

INSTALLING THE FLUE ADAPTOR (200 kW BOILER ONLY)

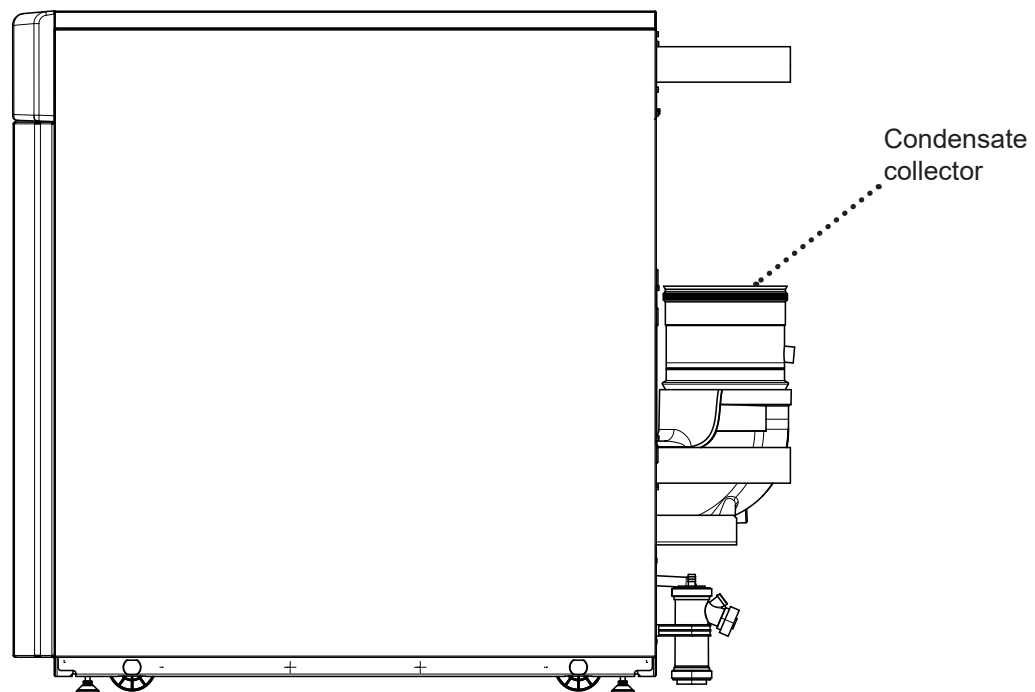

1. Remove the existing flue condensate collector from its location in the boiler flue outlet as shown in the image above.
2. Once the condensate collector has been removed, insert the flue adaptor into the flue outlet ensuring that it is pushed past the lip seal inside the flue outlet and sits on top of the supports that are part of the casting.
3. The flue adaptor has a cutaway which needs to be orientated to the rear of the boiler for clearance against the elbow of the flue outlet as shown in the image below.
4. Ensure that the lip seal is in place within the groove on the flue outlet and adjust where necessary before reinstalling the flue condensate collector.

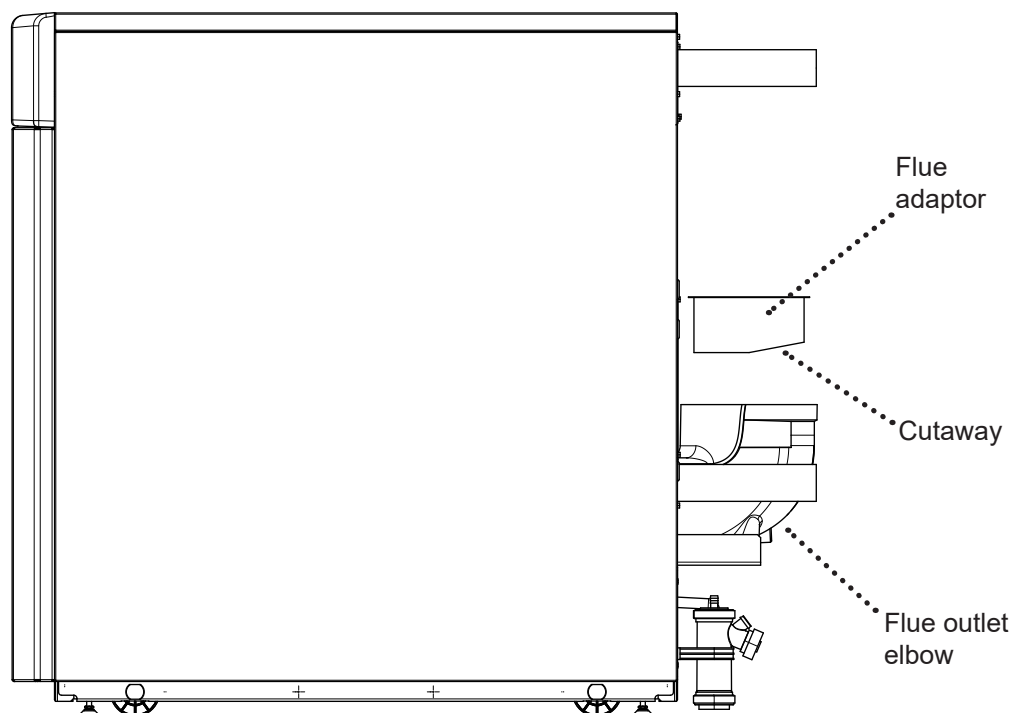

LOADING THE PROPANE PARAMETERS

Steps to follow for boiler with no initial configuration

This is when the Imax boiler has been installed into a facility with the LPG i.e. the Imax will be run on LPG immediately following initial commission.

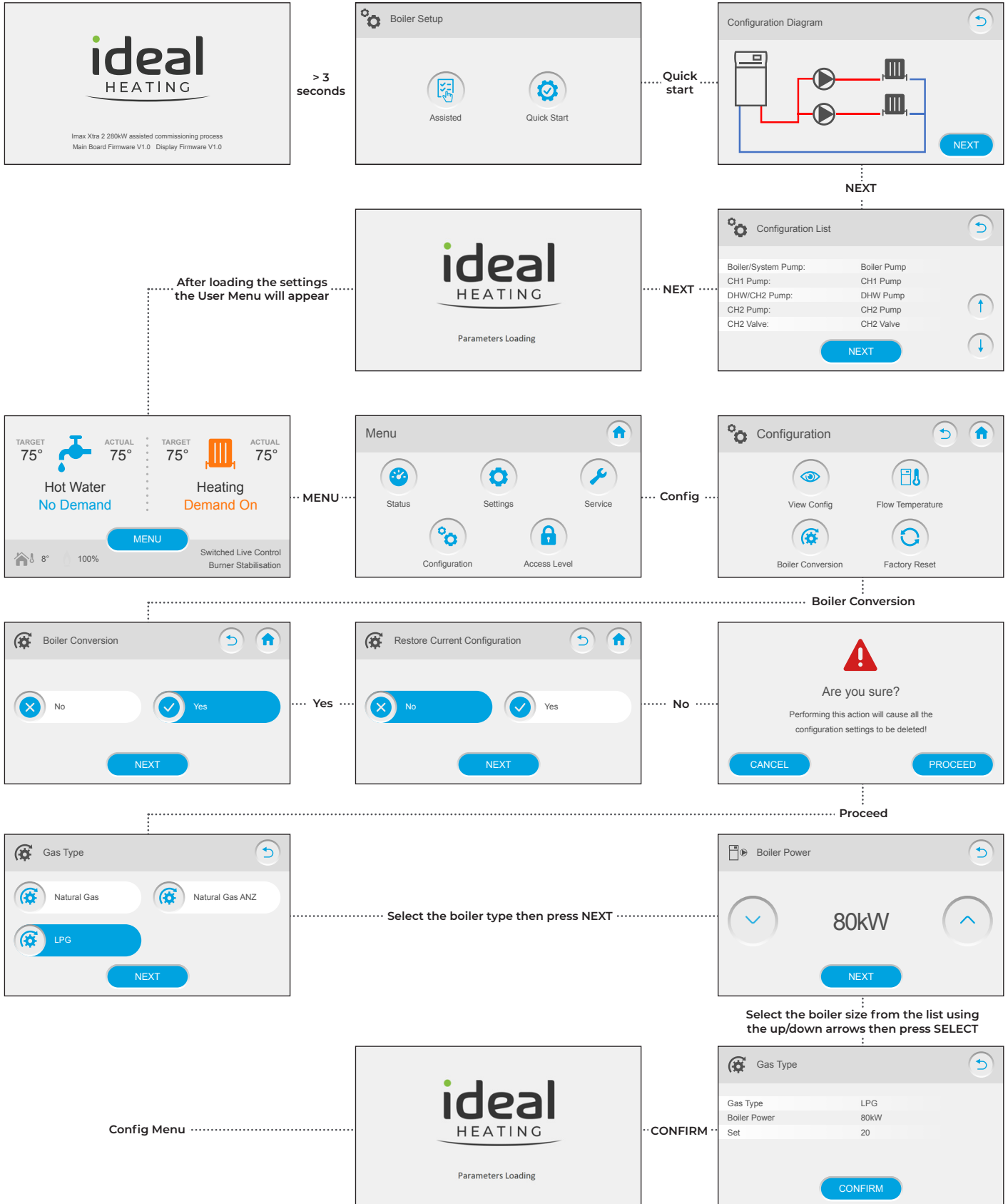

Steps to follow for boiler that has been previously configured

This is when the lmax boiler has been installed and configured i.e. converted from a configured NG boiler to a LPG boiler.

1. Refer to safety section.
2. Enter service mode using access code 529. Please refer to the Installation & Servicing manual for further information on this.
3. Follow the steps below to upload the parameters for propane.

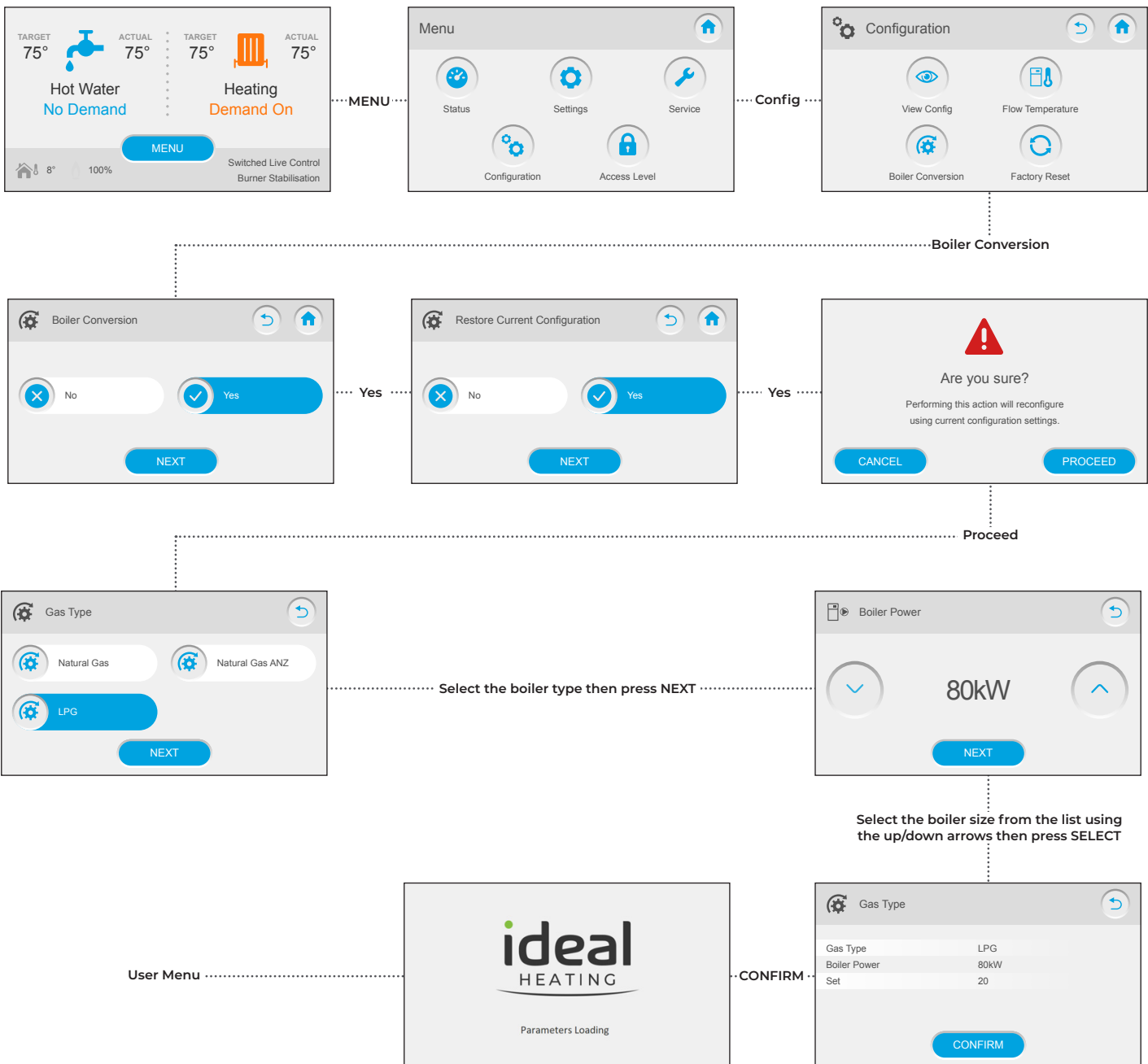

GAS VALVE ADJUSTMENT

Maximum rate adjustment

1. Switch the boiler on and set the boiler into service mode maximum which will last for 10 mins but can be exited earlier.
2. To ensure the boiler operates at maximum rate without modulating, set the fan speed to maximum following the steps in the gas valve adjustment diagram on the next page.
3. Using the maximum rate adjustment screw adjust the valve until the CO2 valve measures 10.8% (Note:- clockwise reduces the CO2).

If this does not measure $10.8\% \pm 0.2\%$ repeat steps 3 to 5 above. Press the Home button to return to the Home screen. Seal the adjustment screw with tamper proof paint and replace caps where applicable.

Minimum rate adjustment

4. To ensure the boiler operates at minimum rate without modulating, set the fan speed to minimum following the steps in the gas valve adjustment diagram on the next page.
5. Using the minimum rate adjustment screw adjust the valve until the CO2 valve measures 10.0% (Note:- Anticlockwise reduces the CO2).
6. Reset the boiler back to maximum rate and measure the CO2.

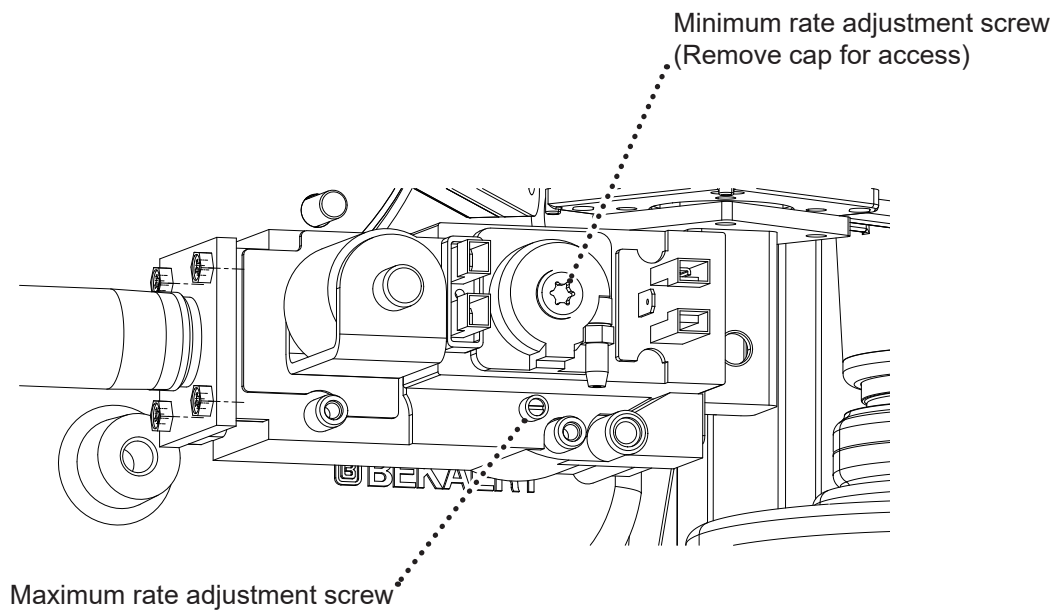

MODELS: 80 kW & 120 kW

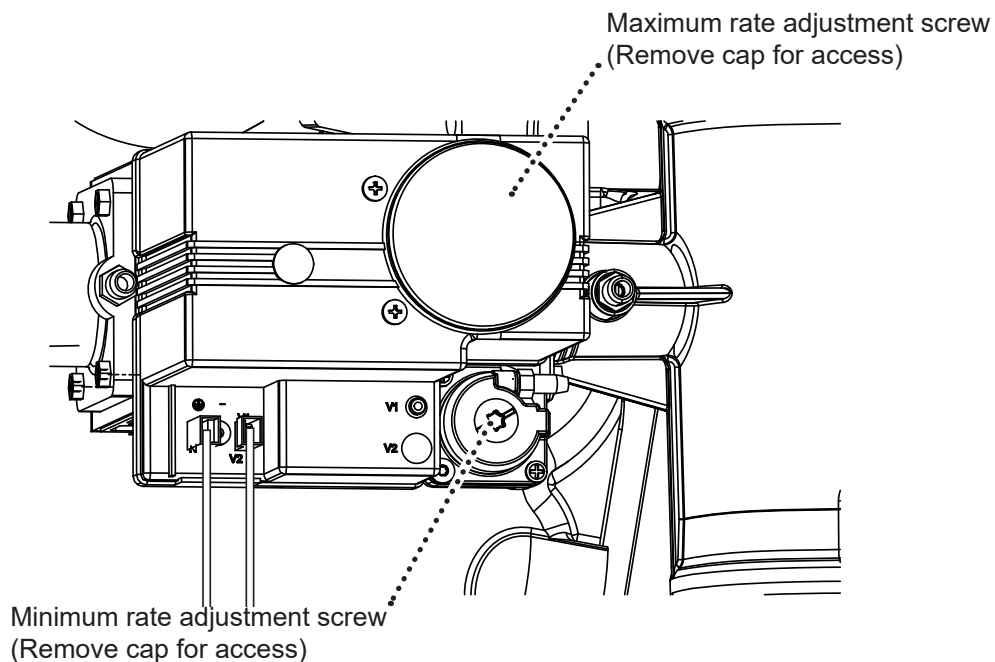

MODELS: 160 kW, 200 kW & 240 kW

ACCESSING SERVICE MODE FOR GAS VALVE ADJUSTMENT

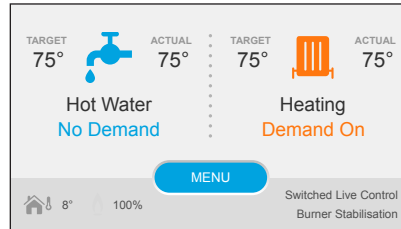

Press MENU

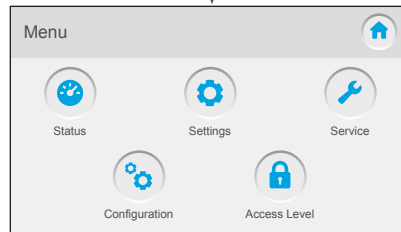

Press Service

To set the boiler to run at Maximum Rate for 10 Minutes press Maximum Rate

To set the boiler to run at Minimum Rate for 10 Minutes press Minimum Rate

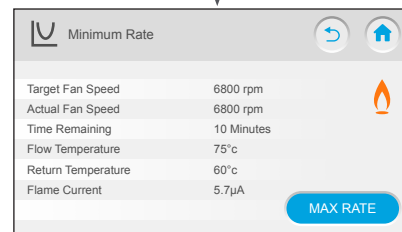
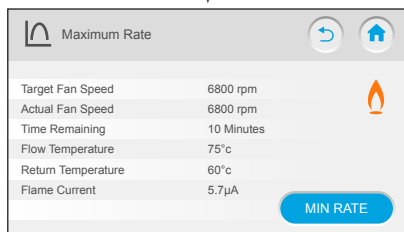

The boiler will run at Maximum Rate for 10 minutes unless the system load is insufficient

The boiler will run at Minimum Rate for 10 minutes unless the system load is insufficient

The boiler will automatically move back to normal operation after 10 minutes

The boiler will automatically move back to normal operation after 10 minutes

To move directly to Minimum Rate press MIN RATE

To move directly to Maximum Rate press MAX RATE

PROPANE DATA LABEL AND OVERLAY

1. Ensure that the boiler has had the correct orifice plate fitted and the parameters have been updated for Propane.
2. The boiler front panel will need to have been removed to expose the location where the labels are to be affixed.
3. Record the date the boiler is being converted to Propane onto the Overlay label that is provided in the kit.
4. Record the original boiler serial number (located on the Natural Gas Data Label) onto the Overlay label and the two tear off strips.
5. Once all details have been recorded, adhere one of the two tear off strips over the existing label at the rear of the boiler and the other one over the existing label on the cover of the installation manual.
6. Adhere the Overlay label over the existing Natural Gas data label located at the front of the boiler as shown below.
7. Adhere the Propane data plate label that is provided in the kit next to the Overlay label as shown below.

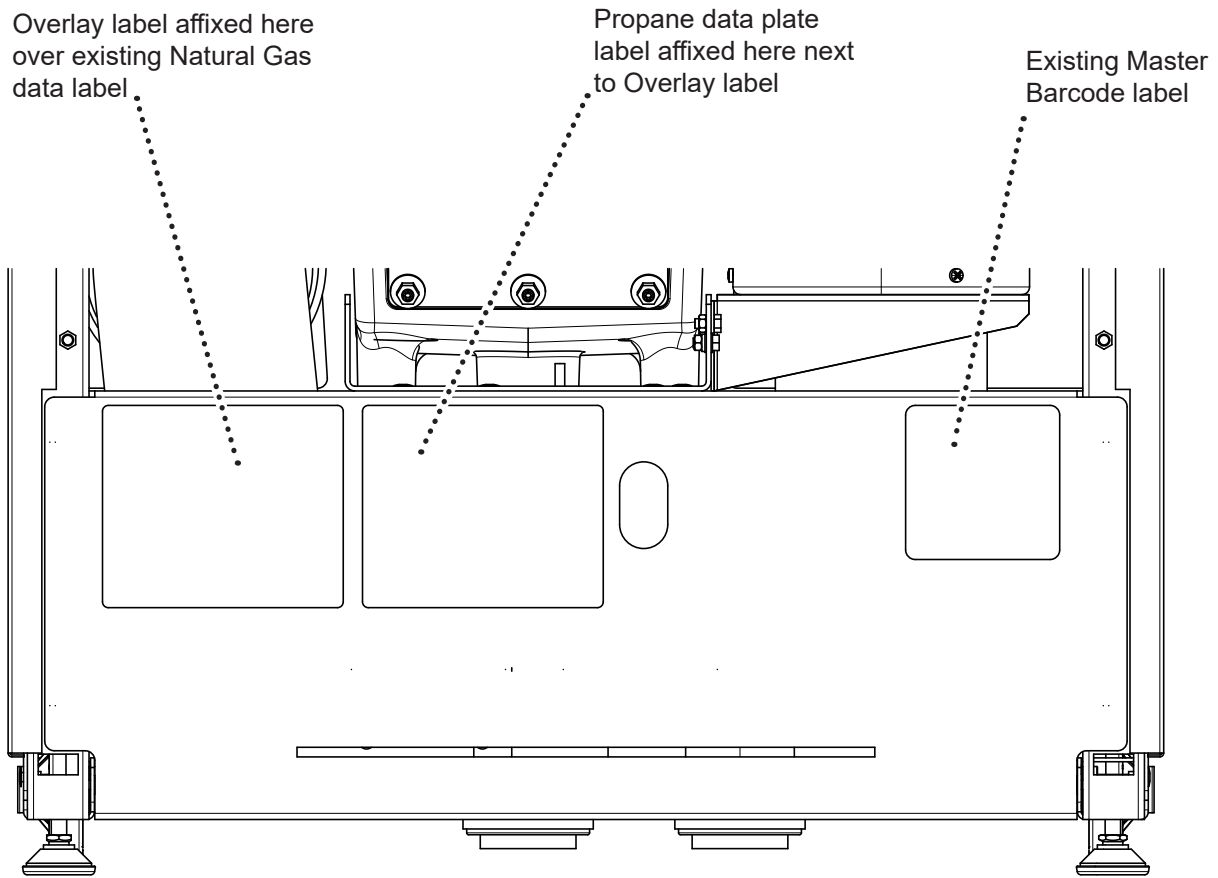

Typical view looking at the front of all boilers (front panel removed)



WEEE DIRECTIVE 2012/19/EU
Waste Electrical and Electronic Equipment Directive

- At the end of the product life, dispose of the packaging and product in a corresponding recycle centre.
- Do not dispose of the unit with the usual domestic refuse.
- Do not burn the product.
- Remove the batteries.
- Dispose of the batteries according to the local statutory requirements and not with the usual domestic refuse.



FM 59915
Manufactured under
an ISO 9001
registered quality
management system

At Ideal Heating we take our environmental impact seriously, therefore when installing any Ideal Heating product please make sure to dispose of any previous appliance in an environmentally conscious manner. Households can contact their local authority to find out how. See <https://www.gov.uk/managing-your-waste-an-overview> for guidance on how to efficiently recycle your business waste.

Technical Training

Our Expert Academy offer a range of training options designed and delivered by our experts in heating. For details please contact:
expert-academy.co.uk

Ideal Boilers Ltd., pursues a policy of continuing improvement in the design and performance of its products. The right is therefore reserved to vary specification without notice.

Ideal is a trademark of Ideal Boilers.

Registered Office

Ideal Boilers Ltd., National Avenue, Hull, East Yorkshire, HU5 4JB

Tel 01482 492251 Fax 01482 448858

Registration No. London 322 137

Ideal Commercial Technical Helpline: 01482 498376

Ideal Parts: 01482 498665

idealheating.com

ideal
HEATING