

BRAZED PLATE HEAT EXCHANGER

750kW



Compact design



Separates system
water from the boiler



Low maintenance
and self-cleaning



Used with Ideal
Heating Cascade kits

BRAZED PLATE HEAT EXCHANGER 750kW

TECHNICAL SPECIFICATIONS

750kW is the nominal capacity of the plate heat exchanger applying the operating conditions shown below. Please contact Ideal Heating to confirm the expected performance if the operating conditions differ from those shown.

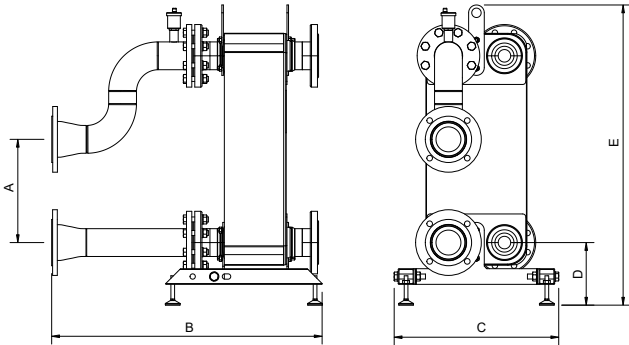

DIMENSIONS

	DIM A	DIM B	DIM C	DIM D	DIM E
DN100	330	830	520	200	959
DN150	330	872	520	200	960

	UNITS	HOT SIDE	COLD SIDE
Mass flow rate	kg/s	8.98	8.98
Inlet temperature	°C	80	50
Outlet temperature	°C	60	70
Pressure drop	kPa	14.5	20.2
Heat exchanged	kW	750	
Heat transfer area	m ²	17.6	
Flow configuration		Countercurrent	
Number of plates / thickness		72 / 0.3mm	
Number of passes		1	1
Pressure vessel code		PED	
Design pressure at 90.00 Celsius	Bar	19	19
Design pressure at 225.0 Celsius	Bar	15	15
Design temperature	°C	-196.0 / 225.0	
Overall length x width x height	mm	365 x 324 x 959	
Volume	L	22.9	14.6
Net weight, empty / operating	kg	66.1 / 103	

STANDARD MATERIALS

Cover plates	Stainless steel
Connections	Stainless steel
Plates	Stainless steel
Brazing	Copper

PLEASE NOTE:

The plate heat exchangers are to be used for system separation only. They must not be used for the direct production of domestic hot water.

They should not be used for direct heating of swimming pool water where the chlorinated pool water would pass directly through the plate heat exchanger.

CONNECTIONS

FRAME & HEADER

Evomax 2	DN50	DN65	DN80	DN100	DN150
Standard Height Cascade				✓	
Low Height Cascade					

Imax Xtra 2	DN50	DN65	DN80	DN100	DN150
Cascade				✓	✓

SYSTEM

DN80

FLANGED

PN25