

BRAZED PLATE HEAT EXCHANGER

450kW

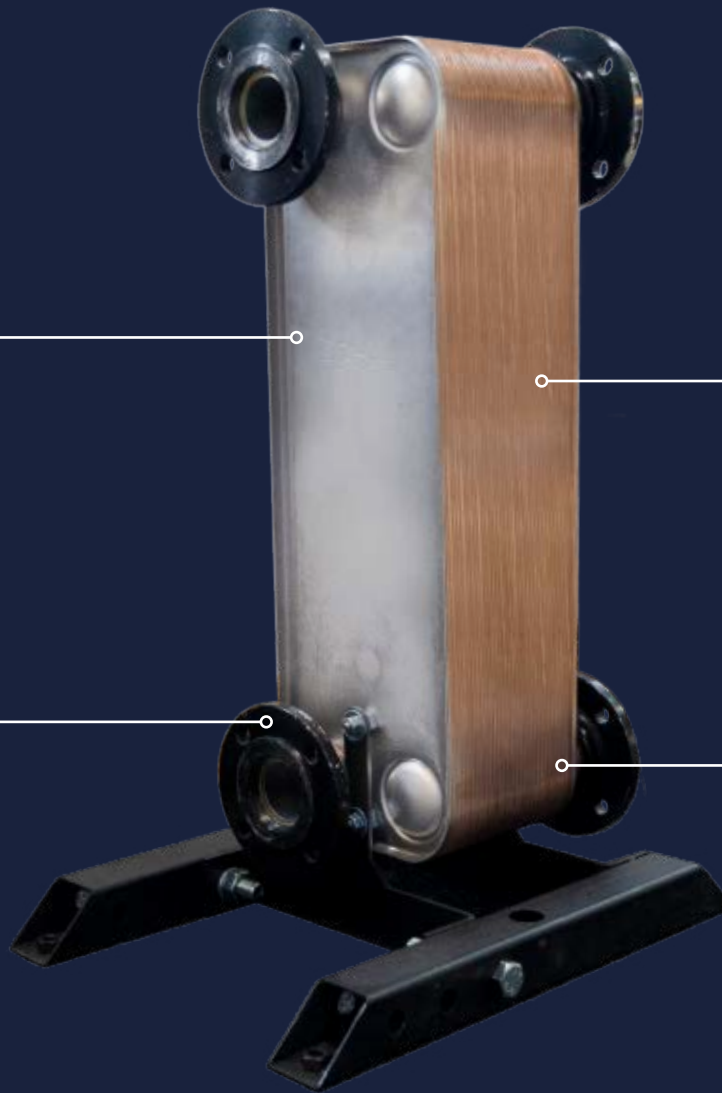

Compact design



Separates system
water from the boiler



Low maintenance
and self-cleaning



Used with Ideal
Heating Cascade kits

BRAZED PLATE HEAT EXCHANGER 450kW

TECHNICAL SPECIFICATIONS

450kW is the nominal capacity of the plate heat exchanger applying the operating conditions shown below. Please contact Ideal Heating to confirm the expected performance if the operating conditions differ from those shown.

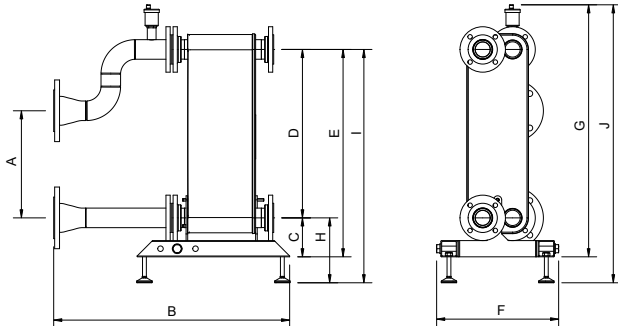

DIMENSIONS

	DIM A	DIM B	DIM C	DIM D	DIM E	DIM F	DIM G	DIM H	DIM I	DIM J
DN80	330	727	120	519	639	376	777	200	719	857
DN100	330	739	120	519	639	376	777	200	719	857

	UNITS	HOT SIDE	COLD SIDE
Mass flow rate	kg/s	5.39	5.39
Inlet temperature	°C	80	50
Outlet temperature	°C	60	70
Pressure drop	kPa	12.9	13.5
Heat exchanged	kW	450	
Heat transfer area	m ²	8.3	
Flow configuration		Countercurrent	
Number of plates / thickness		76 / 0.3mm	
Number of passes		1	1
Pressure vessel code		PED	
Design pressure at 90.00 Celsius	Bar	30	30
Design pressure at 225.0 Celsius	Bar	25	25
Design temperature	°C	-196.0 / 225.0	
Overall length x width x height	mm	293 x 191 x 616	
Volume	L	8.0	7.8
Net weight, empty / operating	kg	32.8 / 48.2	

STANDARD MATERIALS

Cover plates	Stainless steel
Connections	Stainless steel
Plates	Stainless steel
Brazing	Copper

PLEASE NOTE:

The plate heat exchangers are to be used for system separation only. They must not be used for the direct production of domestic hot water.

They should not be used for direct heating of swimming pool water where the chlorinated pool water would pass directly through the plate heat exchanger.

CONNECTIONS

FRAME & HEADER

Evomax 2	DN50	DN65	DN80	DN100
Standard Height Cascade			✓	✓
Low Height Cascade			✓	✓

Imax Xtra 2

	DN50	DN65	DN80	DN100
Cascade			✓	✓

SYSTEM

DN50

FLANGED

PN6

GET A QUOTE     

idealheating.com | 0844 543 6060 | commercial@idealheating.com

EXPERTS IN
HEATING