

ECOMOD CO2Q NATURAL REFRIGERANT HEAT PUMP

95kW



Suitable for commercial properties



High temp up to 70°C



Ultra-low GWP



Quiet noise level as low as 72 dB(A)**



Highly efficient: COP up to 3.4***

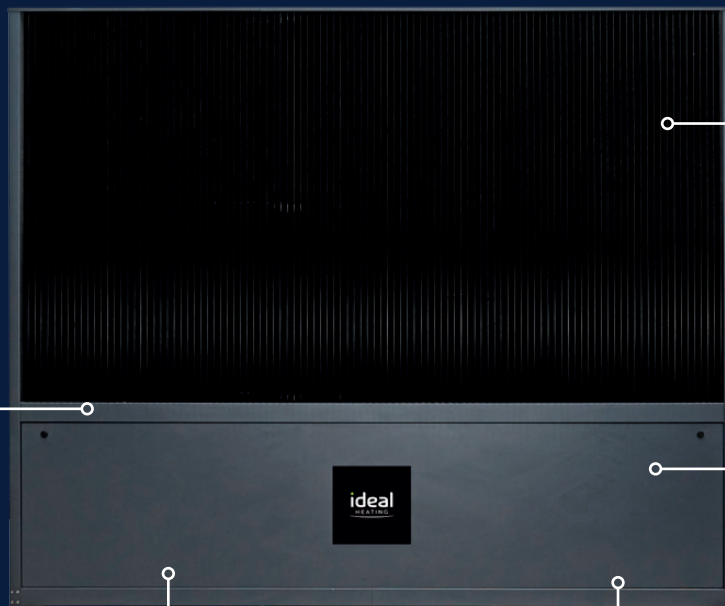

Features and benefits



ECOMOD CO2Q HEAT PUMP 95kW

- Made in the UK
- Monobloc air source heat pump
- Single unit with the refrigeration cycle contained within the outdoor unit
- Inverter controlled compressor to accurately match the heat demand
- Ultra-low GWP of 1 due to the use of R744 (CO2) natural refrigerant
- Highly efficient with coefficient of performance (COP) rating up to 3.4
- Quiet noise level as low as 72dB(A)**
- Suited to larger installations - can be installed in cascade or in back-back arrangement to achieve higher output
- 2 year parts only warranty*
- Combine with Ideal industry leading boilers for a hybrid heating system



We are committed to delivering the highest level of customer service. With more than 100 years' experience in the heating industry, we know how important confidence and trust are to our customers.

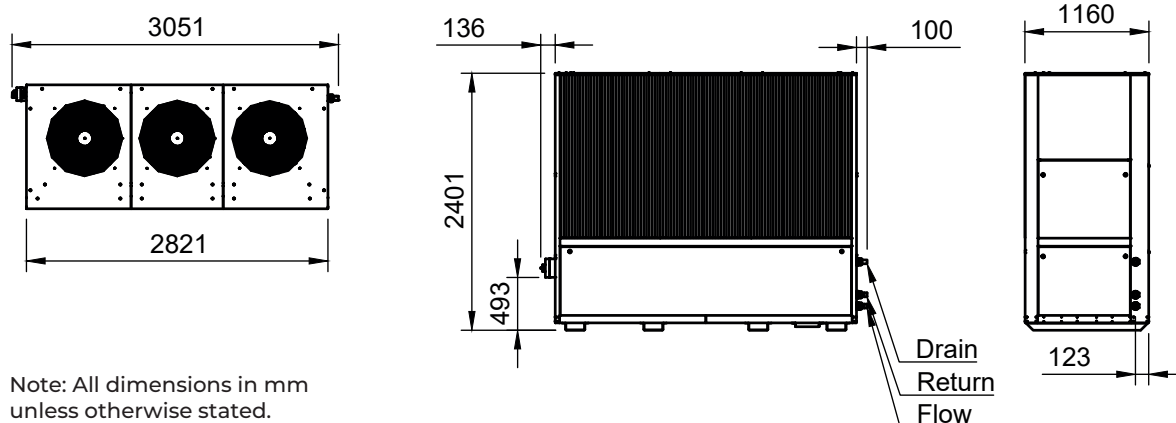

Note: All dimensions in mm unless otherwise stated.

Installation clearances (mm):

FRONT	REAR	LEFT	RIGHT
1000	0	1000	1000

Note: Designed to sit back to wall or in back to back arrangement.

ECOMOD CO2Q HEAT PUMP 95kW

TECHNICAL SPECIFICATIONS



GENERAL

		95kW
Heat Pump Space Heating [55°C]	ErP rating	N/A
	COP	3
Heat Pump Space Heating [65°C]	ErP rating	N/A
	COP***	3.4
Heating (A7/W65)	Capacity (kW)	95
	Power Input (kW)	25
	SCOP	3.5
Maximum Flow Temp	°C	70
Air Temperature Range	Min/Max (°C)	-15 / no max
Sound Data Outdoor Unit	Power Level dB(A)**	72
	Pressure Level at 10m dB(A)#	40
Pipework Connection Sizes	Heating Flow (mm)	35
	Heating Return (mm)	35
Dimensions Outdoor Unit	Width (mm)	3051
	Depth (mm)	1160
	Height (mm)	2401
Weight	kg	1365
	Electrical Supply (v)	400
Electrical Data	Phase	Three
	Max Running Current (Amp)	67.55
	Fuse Rating (Amp)	80
Refrigerant Charge	CO2 (kg)	6.5
GWP (Global Warming Potential)		1

ACCESSORIES AND OPTIONS

	Included	Optional
Master controller		✓
DHW controller		✓
Flexible hoses		✓
Burst disc pressure relief kit		✓
Exogel antifreeze kit		✓
Anti-corrosion Blygold coating available for installations near the sea		✓

Terms and conditions apply.

* 2 year parts only warranty. ** Sound power established in general accordance with BS EN ISO 3740: 2019 with a survey grade accuracy (sR0) = 4 dB. # Sound pressure level at 10m determined in accordance with Annex D of BS EN ISO 13487(TC): 2019. *** Efficiency Coefficient of Performance (COP) rated at EN14825 test conditions Air 7°C / Water 65°C.

ECOMOD CO2 & CO2Q models all represent the output at Air 7°C & Water 65°C.

Every effort has been taken to ensure the details are accurate. Ideal Heating does not, however, guarantee the accuracy or completeness of any information nor does it accept liability for any errors or omissions in the information. Ideal Heating reserves the right to make changes and improvements which may necessitate alteration to product specification without prior notice.



Sales:

03330 040 393

Calls cost no more than calls to geographic numbers (01 or 02) and will be included in any inclusive minutes you have with your telephone service provider.

Technical Help:

01482 498376

Ideal Heating, PO Box 103, National Avenue,
Kingston upon Hull, East Yorkshire, HU5 4JN

commercial@idealheating.com

idealheating.com |    