

ideal
HEATING

EVOMOD

1000kW



NOx Class 6



Floor Standing



ErP
Compliant



BIM



Features & specification

Available in 250, 500, 750 and 1000kW modules, the Evomod will achieve an output up to 1MW from a single unit solution together with a minimum footprint that enables the product to be installed where space is limited. Each module provides a maximum of 250kW heat output and will modulate down through a sophisticated control system.

- **Free Commissioning**
- 5 year heat exchanger warranty*
- Modules up to 3 high stacking
- Stainless steel heat exchanger
- Built in module diagnostics, sequencing and remote indication
- Single flue outlet, system, gas and electrical connections
- Up to 20:1 turndown: 1MW boiler can modulate down to just 46.7kW
- Easy access for servicing
- Minimum footprint with easy site handling and standard doorway access allowing simplified plant replacement
- NOx <40mg/kWh (Class 5)
- 2 year parts and labour warranty
- Up to 108.5% net efficiency (fully condensing)
- Single boiler control for all module options
- ErP compliant (250kW)
- Building Regulation Part L2 compliant (500 - 1000kW)
- MCPD compliant (1000kW)



BOILER ASSEMBLY

EXPLODED VIEW (500kW MODEL SHOWN)

KEY

1. Fan
2. Gas Valve
3. Venturi
4. Mains Connection Box
5. Heat exchanger
6. Thermistor (flow)
7. Thermistor (return)
8. Condensate Blockage Pressure Switch
9. Flue Sampling Point
10. Water Pressure Switch

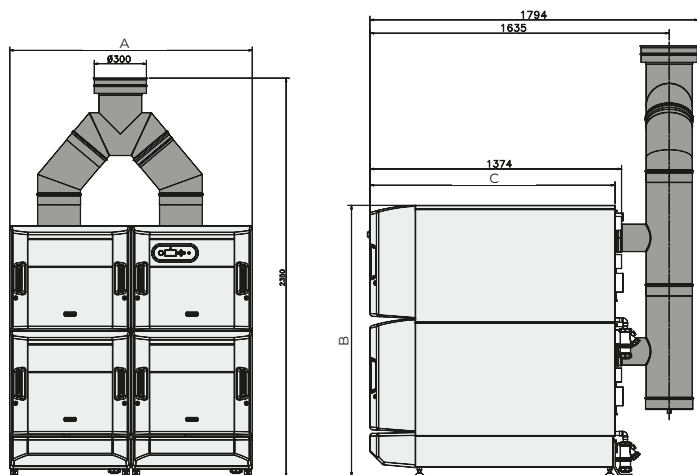

BOILER	DIM A	DIM B	DIM C
1000	1428	1480	1339

DIMENSIONS & CLEARANCES

The following minimum clearances must be maintained for operation and servicing:

- ↑ TOP: 300mm
- ↔ SIDES: LH 400mm
RH 450mm
- FRONT: 600mm
- ↓ REAR: 750mm

EVOMOD 1000kW

TECHNICAL SPECIFICATIONS

GENERAL

Dry Weight	KG	845
Boiler Dimensions	mm	1480 (H) x 1428 (W) x 1339 (D)
Boiler Clearances	mm	Front: 600 Left Side: 400 Right Side: 450 Rear: 750 Top: 300
Seasonal Efficiency	%	95.9
Min / Max Gas Pressure (Nat Gas)	mbar	17 - 20

BURNER PRE MIX

Fuel	(Type G20)	Natural Gas
Fuel Consumption	m ³ /h	100.8
Flame Protection		Ionisation
Ignition		Spark
Boiler Output (Mean 70°C) Min / Max	kW	46.7 - 930
Boiler Output (Mean 40°C) Max	kW	51.4 - 1010
Boiler Input (Gross cv)	kW	1056.4
Gas Inlet Size		2"
NOx Emissions at 0% O ₂	mg/kWh	39.7
NOx Rating		Class 5

HYDRAULICS

Hydraulic Resistance (20°C ΔT)	mbar	410
Nominal Flow Rate (20°C ΔT)	l/s	12.0
Min Flow Rate (20°C ΔT) (MAX MOD)	l/s	2.4
Min Flow Temperature	°C	30
Max Flow Temperature	°C	80
Min Working Pressure	bar	1
Max Working Pressure	bar	6
Max Static Head Of Water	metres	61
Condensate Connection	mm	4 x 21.5
High Limit Set Point	°C	105 flow, 95 return
Flow & Return Size		5" PN16
Water Content	litres	59.2

FLUE/AIR INLET

Flue Size	mm	300
Flue Gas Volume	m ³ /h	1566
Flue Gas Temperature 80/60 (Nat Gas)	°C	80
Max Flue Resistance	Pa	105

ELECTRICAL

Electrical Supply		230/240V 50Hz 1 Ph
Current	A	6.14
Power Consumption	W	1350
Modulating Input	V/dc	0-10V
Fuse Rating	A	4 x 5 Internal
Controls Voltage	V	230 or 0 - 10
Insulation Class IP		IP20

CONTROL OPERATION

On/Off 0-10V DC	Yes
OpenTherm	No
High Limit Protection	Yes
Low Water Protection	Yes
Volt Free Common Alarm	Yes
Boiler Run Indication	Yes

OPTIONAL EXTRAS

Water and Gas Header Assembly package	Yes
Water and Gas Header c/w Valves package	Yes
Water Connection Kit (250 only)	Yes
Air Inlet Collar	Yes

*5 year heat exchanger warranty subject to terms and conditions. 2 year parts and labour warranty as standard. Free Commissioning Offer available subject to terms and conditions. Terms & conditions at idealheating.com

GET A QUOTE     

idealheating.com | 01482 492251 | commercial@idealheating.com

welcome to our ideology

EVOMOD 1000kW

SUGGESTED ENGINEERING SPECIFICATION

The Suggested Engineering Specification is wording designed for specifiers to copy and paste into their specifications to ensure inclusion of Ideal Commercial boilers.

OVERVIEW

The boilers must be fully automatically controlled, floor standing, fanned, super-efficient condensing appliances utilising a stainless steel heat exchanger and be suitable for connection to fully pumped open vented or sealed water systems. The boilers must be modular in design with each module capable of delivering 250kW.

CONTROLS

The condensing boilers must have connectivity for common types of BMS integration including 0-10v and volt free connections. The boiler must be fully modulating with a 5:1 turndown ratio per 250kW module and include control features enabling set point adjustment, heating circuit control of one constant temperature and one DHW circuit or 2 constant temperature circuits, and safety lock out parameters including fault diagnosis for both boiler and external components such as sensors or pumps.

Boiler capabilities must include, with the use of external components, frost protection, weather or room compensation and system pump control.

FLUE

The condensing boilers must be suitable for use with a room sealed flue or open flue applications including C13, C33 and B23 classifications. The flue outlet and air inlet must be situated at the rear of the boiler.

HYDRAULIC

The condensing boiler must be suitable for connection to fully pumped open vented or sealed water systems. All hydraulic connections including flow return and condensate drain must be located on the rear of the boiler. Hydraulic connections must be uniform across the modules available in the range to ensure ease of installation and maintenance. The boiler must have a maximum operating pressure of 6 bar and be suitable for heating and indirect hot water systems.

Please note that the above information is correct at time of publication. Ideal Heating has a policy of continuous development and therefore reserves the right to alter specifications without prior notification.

DIMENSIONS

The condensing boiler must fit within maximum permitted floor space of 0.95m² (when installed 1 module wide) or 1.91m² (when installed 2 modules wide).

MOUNTING

The condensing boilers will be floor standing.

EFFICIENCY

The condensing boilers are capable of high seasonal efficiencies with a minimum requirement of 95.9% and low NOx emissions no greater than 39.7mg/kWh.

APPROVALS

The boilers must be tested by BSI and conform to EN656, EN13856 and EN15417 for use with Natural Gas. Boilers are certified to meet the requirements of the EC Gas Appliance Directive, Boiler Efficiency Directive, EMC and Low Voltage Directive. The manufacturer must be ISO 9001 accredited

SPECIFICATION

The boiler will be capable of flow rates for common systems using 20°C temperature differentials

SOURCING

The condensing boiler must be manufactured or finally assembled in the United Kingdom.

WARRANTY

The boiler must be available with a 2 year warranty.