

LOGIC HEAT INTERFACE UNITS (HIUs)

DESIGN GUIDE



WE HAVE IT **COVERED.**

idealcommercialboilers.com

ideal
COMMERCIAL



Ideal Commercial Boilers is the UK's market leader of high efficiency commercial heating solutions.

Operating from its Hull manufacturing plant and offices since 1906, Ideal Commercial Boilers is one of the few true British manufacturers left in the heating industry.

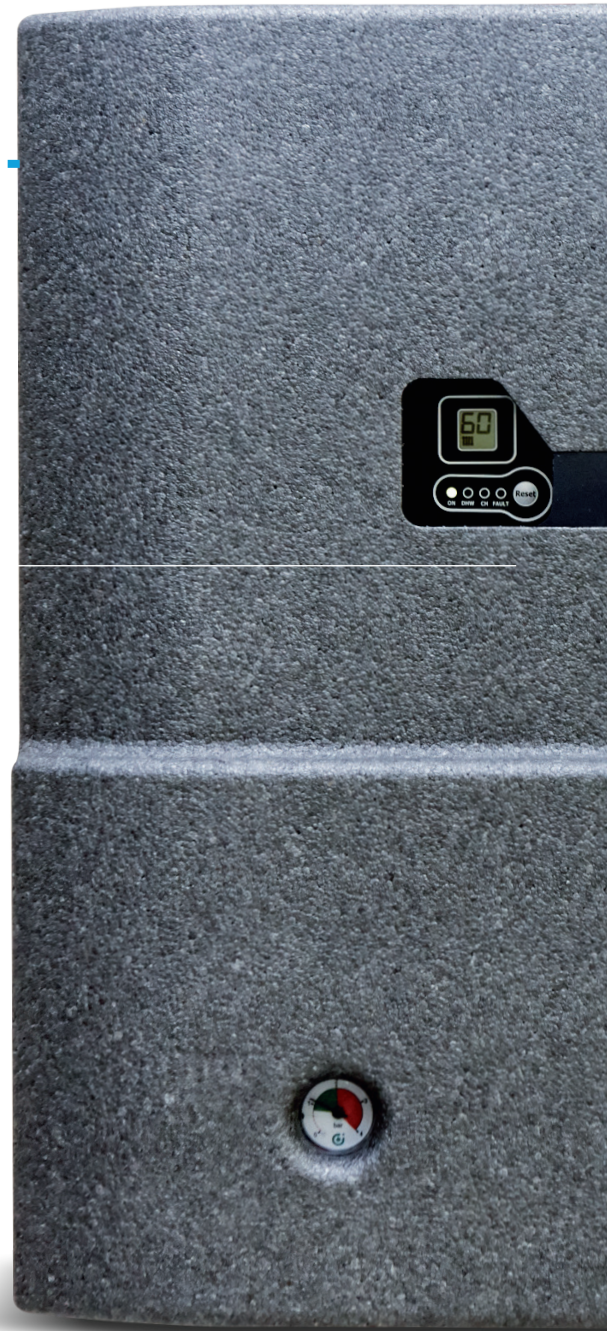



4	HIU Introduction
6-7	Logic HIU Indirect
8-9	Logic HIU Direct
10-14	Features and Benefits of the Ideal Logic HIUs
15	Typical System
16-18	Typical System Components
19	Diversity Factor
20-21	Effect of Diversity Factors
22-23	Commissioning and Checks
24-25	Notes
26-27	Ideal Training & Support

LOGIC HIU

INTRODUCTION

2 YEAR
WARRANTY

This guide explains how to design and commission heating systems for apartment buildings and district heating schemes incorporating Ideal Logic Heat Interface Units (HIUs).

Ideal Logic HIUs incorporate one or two plate heat exchangers to transfer heat from a central boiler plant to individual heating and hot water systems within apartments.

Ideal HIUs incorporate an internal electronic control unit which ensures not only maximum efficiency, improved reaction time and control but also provides other additional features.

Modulating valves control the supply of hot water to both the space heating and domestic hot water within the apartment.

The thermally insulated casings minimise heat loss from the unit.

Maximum energy saving from the HIUs can only be achieved if the system is designed correctly and HIUs are selected to match DHW and heating requirements.

To ensure maximum efficiency, reliability and performance the system must be designed and commissioned in accordance with CIBSE.



TYPICAL SYSTEM

The Ideal Heat Interface Units are heat energy transfer units. Designed for use in conjunction with centralised boilers, district heating or central energy systems. The function is to efficiently transfer heat from the plant room to the individual dwelling's central heating (CH) and domestic hot water (DHW) systems.

BENEFITS

THE BENEFITS OF IDEAL LOGIC HIUs ARE:

- Compact design requiring a minimum amount of space
- Minimal routine maintenance since they do not require regular servicing or maintenance
- All the Logic HIUs incorporate a spacer piece which can be easily removed and a heat meter fitted inside the unit. This allows the energy used by each individual apartment to be recorded and charged accordingly
- Fast acting control valves adjust to changes in the primary system pressure and secondary demands

THE LOGIC HIU RANGE HAS TWO METER OPTIONS AVAILABLE:

- CF ECHO II
- CF ULTRAMAXX V

Depending upon the meter chosen the energy used can be monitored and recorded allowing for billing and data recording via a suitable MBUS or similar network.

ABOUT HIU

- A central boiler plant room or energy centre in a communal or district heating system can be more efficient than individual boilers or hot water cylinders improving the SAP rating of the building depending on the fuel chosen.

This provides benefits in achieving target ratings under the Code for Sustainable Homes requirements

- Central boiler plant or energy centres facilitate the simpler introduction of low carbon technology to the benefit of all tenants. This can include combined heat and power, solar heating or biomass boilers
- An Ideal HIU maximises the energy efficiency of the central boiler plant by enabling the return water from the primary system to have a lower temperature. A low return water temperature is important to the efficiency of gas fired condensing boilers, combined heat and power units, solar panels and ground source heat pumps
- Part L typically recommends that the return water temperature from a communal heating scheme should not exceed 40°C for hot water systems and 50°C for radiator systems



SAP RATING

SAP has been adopted by the Government as part of the UK's national standard for calculating the energy performance of buildings.

Every new building has to have an SAP rating. It provides a simple means of reliably estimating the energy efficiency.

SAP ratings are expressed on a scale of 1 to 100, the higher the number the more energy efficient the building.

- The Legionella bacteria can multiply in stored or stagnant water between 25 to 45°C. Below 20°C the bacteria can survive but are dormant and above 60°C most die within 2 minutes
- The Ideal Logic HIUs provide instantaneous hot water minimising the risk of Legionella bacteria multiplying since there is no stored hot water
- All Ideal HIUs are supplied with a lockable fully insulated cover, manufactured from EPP which fully insulates the unit and a sliding window allows the tenant access to the heat meter if fitted
- This insulated cover minimises heat loss from the HIU, resulting in lower energy use and prevents overheating of the cupboard space where the HIU is located, ensuring as much heat is delivered to the apartment is useful heat and heat loss from the Logic HIU is a minimum

IDEAL LOGIC HIUs

The Direct and Indirect Logic HIUs are outlined on the following pages but for more detailed information on each unit please refer to the individual product specification sheet.

LOGIC HIU

INDIRECT



LOGIC HIU 75 INDIRECT



LOGIC HIU 50 INDIRECT

The twin plate design hydraulically separates the domestic water from the space heating supplied directly from the central boiler plant.

The on-board electronic control unit ensures maximum efficiency and control but crucially also enables additional important features.

The standard unit can be set to hold a stable heating flow temperature, to suit the installation (radiators, UFH for example), but crucially, can also be set to vary the heating flow temperature automatically depending on the temperature of the heating return water.

This allows the unit to automatically compensate for changes due to external influences, such as outside temperature etc. thereby ensuring that the unit and the system operate at maximum efficiency.

OPERATION

HEATING

The temperature setting operates on the principle of set point regulation and can be fixed within application limits.

Heating Set Point - 25 to 75°C
25 to 50°C (underfloor operation)

DOMESTIC HOT WATER - DHW

The DHW function takes priority over the heating function controlled by the DHW priority flow switch (component 10).

Set Point - DHW temperature 42 to 60°C.

2 YEAR
WARRANTY

UIN	PRODUCT NAME	METERING OPTIONS
211094	Logic HIU Indirect 50	HIU only, meter not included
211347	Logic HIU Indirect 50	Factory fitted, CF Echo 11 Mbus 1
211351	Logic HIU Indirect 50	Factory fitted, CF Ultramaxx V Mbus PS
211093	Logic HIU Indirect 75	HIU only, meter not included
211346	Logic HIU Indirect 75	Factory fitted, CF Echo 11 Mbus 1
211350	Logic HIU Indirect 75	Factory fitted, CF Ultramaxx V Mbus PS

COMPONENTS

- | | |
|---|---|
| 1 Primary isolation valve | 14 Heating flow temperature sensor |
| 2 Drain cock | 15 Temperature control stat |
| 3 Heat meter pipe piece - Replaced by heat meter when fitted | 16 Strainer (heating circuit) |
| 4 Primary filter and heat meter probe pocket | 17 Pump safety bypass and DP switch |
| 5 Heating circuit on/off valve | 18 Pump |
| 7 Modulating primary control valve (DHW) | 19 Expansion vessel |
| 8 Plate heat exchanger (DHW) | 20 Safety relief valve - 3 bar |
| 9 DHW temperature sensor | 21 Heating return temperature sensor |
| 10 DHW flow switch | 22 Pressure gauge |
| 11 Electronic control unit | 23 Filling loop isolation valve |
| 12 Room controller (not supplied) | 24 Filling loop double check valve |
| 13 Plate heat exchanger (space heating) | 25 Filling loop |

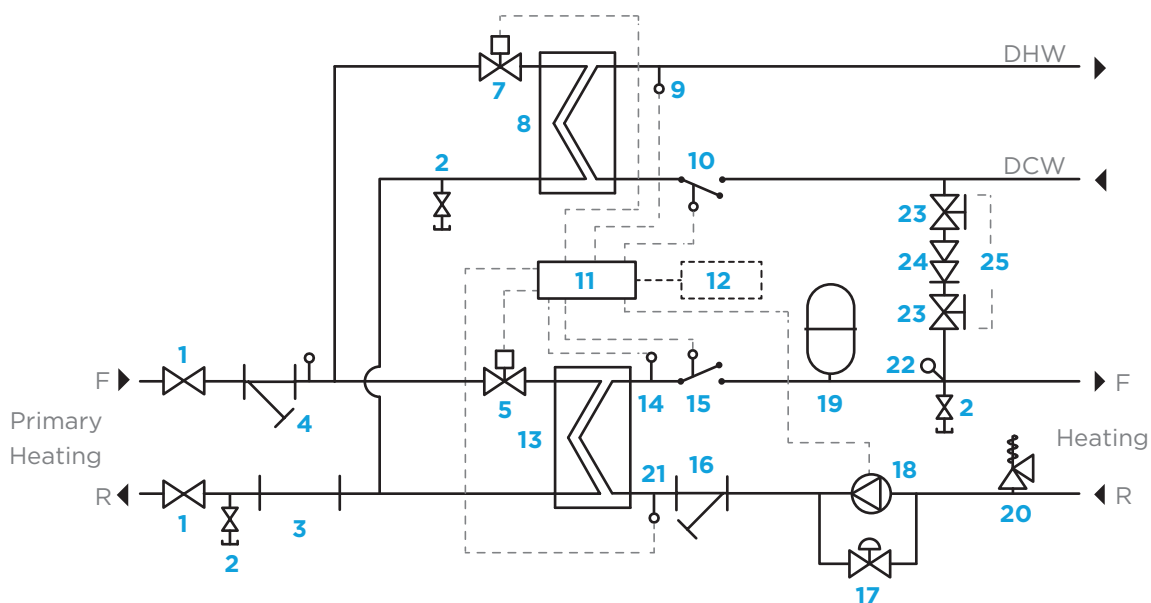

LOGIC HIU

DIRECT



LOGIC HIU 50 DIRECT
MEDIUM TEMPERATURE (MT)



LOGIC HIU 50 DIRECT
HIGH TEMPERATURE (HT)

The single plate design hydraulically separates the domestic water with the space heating supplied directly from the central boiler plant.

The on-board electronic control unit ensures maximum efficiency and control but crucially also enables additional important features.

The Direct unit is available in two versions - High temperature and Medium temperature with compensated heating.

The Logic HIU 50 MT come, as standard, with a pump & bypass loop in case of complete radiator TRV shutdown.

The Logic HIU 50 HT has no heating pump and relies on the central plant circulation pump to provide flow to the radiators and therefore will require a system bypass if TRV's are fitted on all radiators.

OPERATION

HEATING

The temperature setting operates on the principle of set point regulation and can be fixed within application limits.

Logic HIU 50 MT (211095) 45 to 65°C

Logic HIU 50 HT(211096) 50 to 85°C

DOMESTIC HOT WATER - DHW

The DHW function takes priority over the heating function controlled by the DHW priority flow switch (component 10).

Set Point - DHW temperature 42 to 60°C.

2 YEAR
WARRANTY

UIN	PRODUCT NAME	METERING OPTIONS
211095	Logic HIU Direct MT	HIU only, meter not included
211348	Logic HIU Direct MT	Factory fitted, CF Echo 11 MbBus 1
211352	Logic HIU Direct MT	Factory fitted, CF Ultramaxx V MBus PS
211096	Logic HIU Direct HT	HIU only, meter not included
211349	Logic HIU Direct HT	Factory fitted, CF Echo 11 MbBus 1
211353	Logic HIU Direct HT	Factory fitted, CF Ultramaxx V MBus PS

COMPONENTS

- 1 Primary isolation valve
- 2 Drain cock
- 3 Heat meter spacer pipe - replaced by heat meter when fitted
- 4 Primary filter and heat meter probe pocket
- 5 Heating circuit on/off valve
- 6 Differential pressure control valve (DPCV)
- 7 Modulating primary control valve (DHW)
- 8 Plate heat exchanger (DHW)
- 9 DHW temperature sensor
- 10 DHW flow switch
- 11 Electronic control unit
- 12 Room controller (not supplied)
- 14 Heating flow temperature sensor
- 15 Temperature control stat
- 17 Pump safety bypass and DP switch
- 18 Pump
- 26 Modulating heating control valve

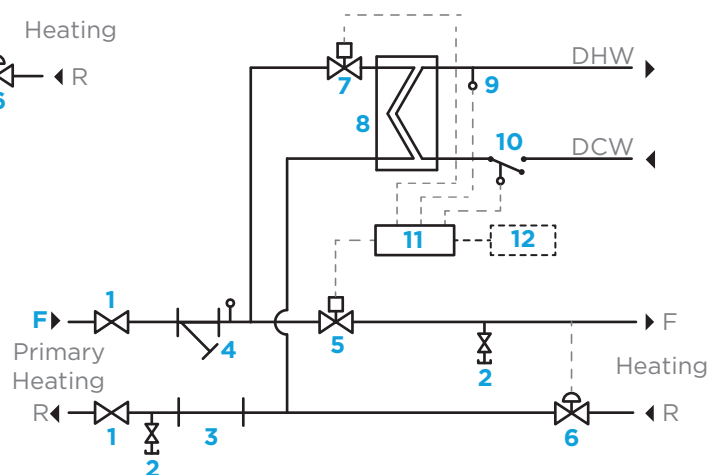
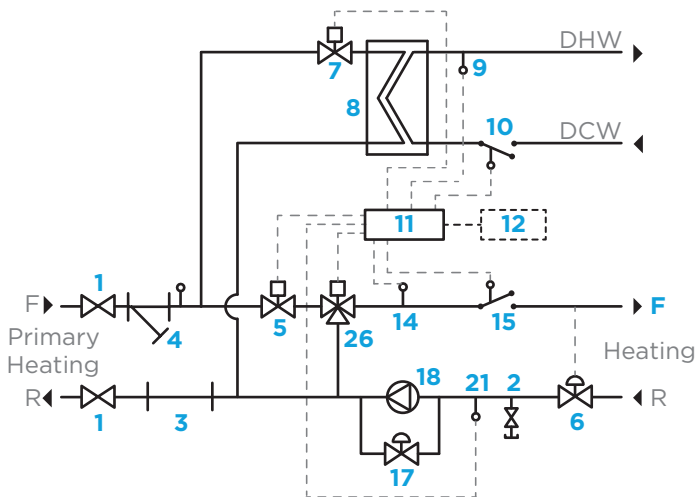

FEATURES AND BENEFITS OF THE IDEAL LOGIC HIUs

CONTROL UNIT

Both the domestic water exchanger and the heating exchanger (if fitted) are controlled by electronic valves.

The electronic valves are controlled by an integral control unit that monitors a number of sensors within the HIU. The electronic control valves respond extremely quickly to changes in primary system pressures and to changes in demand within the apartment.

PRE-SET DOMESTIC HOT WATER & HEATING TEMPERATURES

The pre-set domestic hot water and heating temperatures are very accurately controlled reducing energy wastage and ensuring an accurate and stable DHW temperature at the hot water outlet.

CONTROL UNIT PROGRAMS

Information from the integral sensors is interpreted by the control unit and 'instructions' are sent to the control valves.

The various measurement points within the Logic HIU provide the control unit with valuable information about the current demand and state of the secondary circuits.

The control unit can then run various 'programs' based on this information to ensure that the Logic HIU operates at the highest efficiency.

COMPENSATED HEATING TEMPERATURES (NOT LOGIC HIU 50 DIRECT HT)

When running in this mode, the Logic HIU constantly measures the heating circuits return temperature.

If this temperature starts to rise as say the room/building becomes satisfied or due to solar gain for example, the Logic HIU will automatically start to reduce the flow temperature out to the heat emitters.

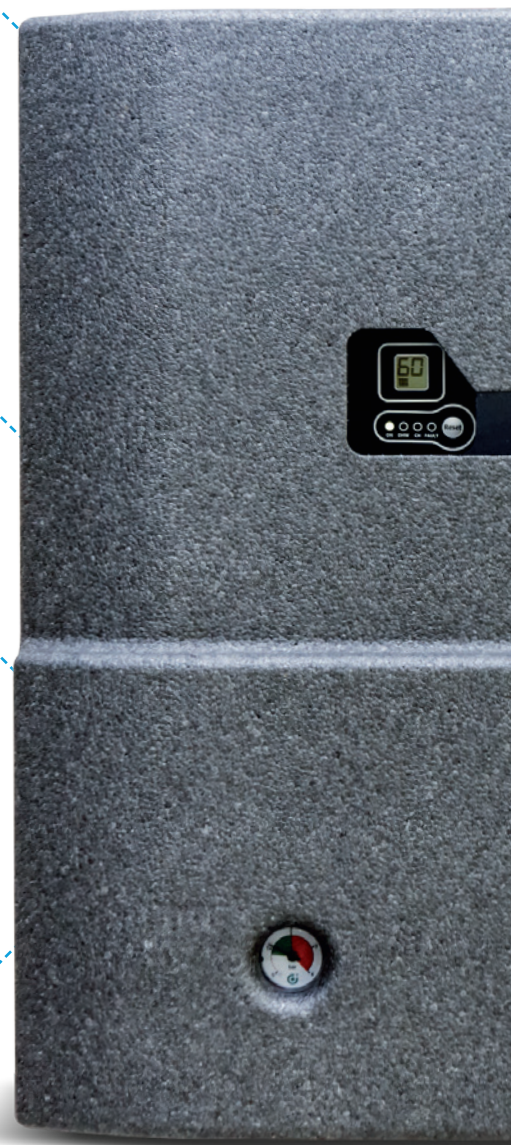

DOMESTIC HOT WATER PRIORITY

Ideal HIUs are set to give 100% domestic hot water priority which is the typical requirement for HIUs. The priority of the Logic range can be set within the controller to deliver a mix of heating and DHW if required, such as 90/10,80/20 etc. thereby ensuring that rooms do not go cold during periods of long hot water demand, such as running baths etc. Giving the designer more flexibility with the specification.

This can be very important on luxury apartments with multiple bathrooms, higher than average tenant numbers or when DHW storage cylinders are utilised. (Ideal Thermstore cylinders).

ELECTRONIC CONTROL VALVES

Utilising electronic control valves also allows the HIU to be made smaller and lighter.

Firstly, the valves are far smaller than most mechanical valves. Secondly it's now possible to 'wire in' multi functions for each valve.

Unlike conventional HIU systems, the electronic valve in the Ideal Logic HIU can provide both on off control and pressure control functions, controlling the primary flow through the plates and acting as the on/off valve for the tenant's room controller. In addition, as this valve is pressure independent, then a separate DPCV is no longer required.

CONSTANTLY MONITORED DOMESTIC HEAT EXCHANGER

Most HIUs have a primary 'trickle' bypass to ensure that the HIU is warm and ready to produce DHW quickly when required. With conventional HIUs this bypass is open all the time, 24 hours a day, 365 days a year resulting in wasted energy use. This could contribute to overheating of communal areas.

The Ideal Logic HIU, constantly monitors the temperature of the domestic hot water plate heat exchanger. If the temperature drops below a pre-set value, the bypass will open, bring the plate up to temperature then close, only opening again should the plate drop below the preset limit. The result is a dramatic reduction in wasted energy, reduction of scale formation and comfort for the end user.

HEATING CIRCUIT PRESSURE SENSOR

The secondary heating circuit is fitted with a pressure sensor that feeds back information to the controller. If the system pressure drops to 0.4bar, this will be detected by the HIU and the unit will automatically cut the power to the integral Grundfos pump and display a heating error (4) and warning LED fault light on the front display.



PUMP ANTI-SEIZE FEATURE

During the summer months or if the tenant is away on holiday, an apartments heating system might not be used for many weeks. It's possible in these situations that pumps can seize. The anti-seize feature activates

every 24 hours when the system is not used. The HIU will run the pump for 5 seconds ensuring that it stays in optimum condition.

AUTOMATIC FLOOR DRYING CYCLE (UNDERFLOOR)

The Direct and Indirect range have a built in automatic floor drying cycle.

It's important with under-floor heating at the time of construction that the floor slab dries out slowly to reduce the possibility of cracking.

When the under-floor heating drying cycle is selected, this holds the secondary heating temperature at 25°C and then automatically, but slowly, increases the heating temperature over 240 hours up to 40°C, ensuring a consistent and gradual drying of the floor slab.

PUMP BYPASS & DIFFERENTIAL PRESSURE SWITCH

The majority of conventional HIUs require the installer to fit an 'open' radiator or a separate, valve controlled bypass, on the apartments heating circuit.

This is to ensure that the HIU pump doesn't pump against a closed 'head', should all the radiator TRV's close down. Fitting an external bypass involves more work and cost, or potentially over-heating a room, if the open radiator is the chosen option.

The Ideal Logic HIU solves both of these problems by including a pump bypass and differential pressure switch inside the unit.

Every radiator can then have a TRV and if they all close down, the pump is protected by the internal bypass.

TAMPER PROOF INSULATED COVER

All Ideal Logic HIUs have an anti tamper insulated cover ensuring minimal heat losses from the unit.

To prevent the tenant opening or removing the cover and touching hot pipes or changing the units settings, the cover is fixed in place. However, it's important that the tenant can see how much energy they have

used and to facilitate this, the Ideal Logic HIU has two important features.

The cover of the Logic HIU has an integral window that slides up revealing the energy meter's display window. Alternatively, the display part of the meter can be removed from the body of the meter and installed outside of the HIU.

LIGHTWEIGHT & COMPACT

The design of the Logic HIU incorporating electronic control has reduced the requirement for additional mechanical controls, resulting in reduced weight and size.

The Indirect (twin plate) HIU for example weighs from just 19kg, compared to more than 30kg for a comparable competitors unit.

LCD DIGITAL INDICATOR

The control unit of the HIU has an integral LCD window with a digital display, making the set-up of the unit quick and easy.

With conventional HIUs, setting the temperature of the domestic hot water involves multiple trips back and forth from the HIU to the hot water outlet, constantly adjusting a valve until the water meets the required temperature.

With all the Logic HIU models, the temperature of the DHW can be set digitally via the display. Simply set the temperature required at the unit and it's done!

It's exactly the same for the required heating temperature.

BENEFITS OF LOW RETURN TEMPERATURES

This is a key aspect to system efficiency that has been recognised by building regulations and in particular the Domestic Building Compliance Guide (HM Government - a support document for Part L) that stipulates the recommended return temperatures of communal systems.

The guide details the maximum recommended return temperatures for the various system types.

It states that the primary return temperature should be less than 40°C for both instantaneous systems and stored systems domestic water systems.

With an instantaneous system, when on domestic water load, the return temperature will be between 20 and 35°C (depending on manufacturers equipment used) and therefore well below this maximum figure.

RETURN WATER TEMPERATURE

The return temperature has significant effect on system sizing and efficiency.

When sizing the primary pipework and the energy centre, the flow rates and or kW's required are calculated based on the following equation.

$$l_s = \frac{kW}{4.2 * \Delta T}$$

The larger the ΔT (i.e. the difference between flow and return temperatures), the smaller the required flow rate.

Therefore a typical instantaneous system will have an 80°C primary flow and a return of 27.5°C (using an average between the manufacturers), giving a very large ΔT of 52.5°C. Subsequently, the buffer vessels are smaller, as are the pumps and the primary pipework.

CONDENSING BOILERS.

This low return temperature also has a major effect on performance of the condensing boilers in the plant room and any renewable energy sources integrated within.

Condensing boilers need to condense to be efficient. To be able to condense, they need a low return temperature.

However, the lower the return temperature, the more the boiler will condense and the more efficiently it will run.

If the return temperature is higher than 50°C, then no gain can be had from any installed solar system or heat pump.

COMBINED HEAT & POWER UNITS (CHP)

CHP units are installed to produce heat and electricity. They also benefit from low return temperatures.

Electricity is more expensive than gas and has the greater carbon footprint. The electricity supplied from power stations is generally around 38% efficient by the time it arrives at the building. It therefore makes sense to address the electricity demand within a building with CHP.

One of the reasons CHP's can be very efficient is that the resultant heat produced as a by-product of electricity production can be utilised in the building for the LTHW system.

If the CHP is unable to dispose of its heat into the building system, it will switch off and stop electricity production even if there is a high electrical demand within the building.

One of the ways to counter this is to use a heat sink allowing the engine to release its heat to atmosphere so that it can continue to run.

The low return temperature from the instantaneous heat interface unit will allow the CHP to get rid of its heat easier and more reliably, maximising its run time and therefore allowing for longer periods of electricity production and greater performance.

COMPARISON BETWEEN STORED & INSTANTANEOUS HOT WATER

There are advantages and disadvantages to both instantaneous hot water generation and the storage of domestic hot water. This does not mean that the systems are similar or that there's no real benefit of one over the other.

Instantaneous hot water generation, in the large majority of instances, results in a more efficient system overall, providing the system is installed correctly and commissioned accordingly.

Whenever domestic water is stored, a potential Legionella risk is inherent. To combat this risk, the stored water needs to be kept above 60°C to kill off the bacteria.

60°C is a far higher temperature than that required at the terminal outlets (taps, showers, basins, baths etc.).

Therefore, even though the actual required temperature of the DHW is circa 45 to 48°C, additional energy needs to be taken from the primary system and the energy centre to lift the domestic water from the required 48°C, to above 60°C.

This is simply wasted energy that would not be used if instantaneous domestic water generation is utilised.

On an additional note, the subsequent high temperature of the stored domestic water now also requires the installation of thermostatic mixing valves at the terminal units to ensure that the tenants cannot be scalded from this 'overheated' domestic water.

Storing the domestic hot water, just in case it may be required, also results in greater heat losses.

TYPICAL SYSTEM

The schematic opposite shows a typical system with central boiler plant, roof mounted solar thermal collectors, buffer storage and Ideal Logic HIUs.

BSRIA GUIDE

BSRIA Guide BG 12/2011 'Energy Efficient Pumping Systems' gives advice on the design of variable flow systems.

TYPICAL SYSTEM

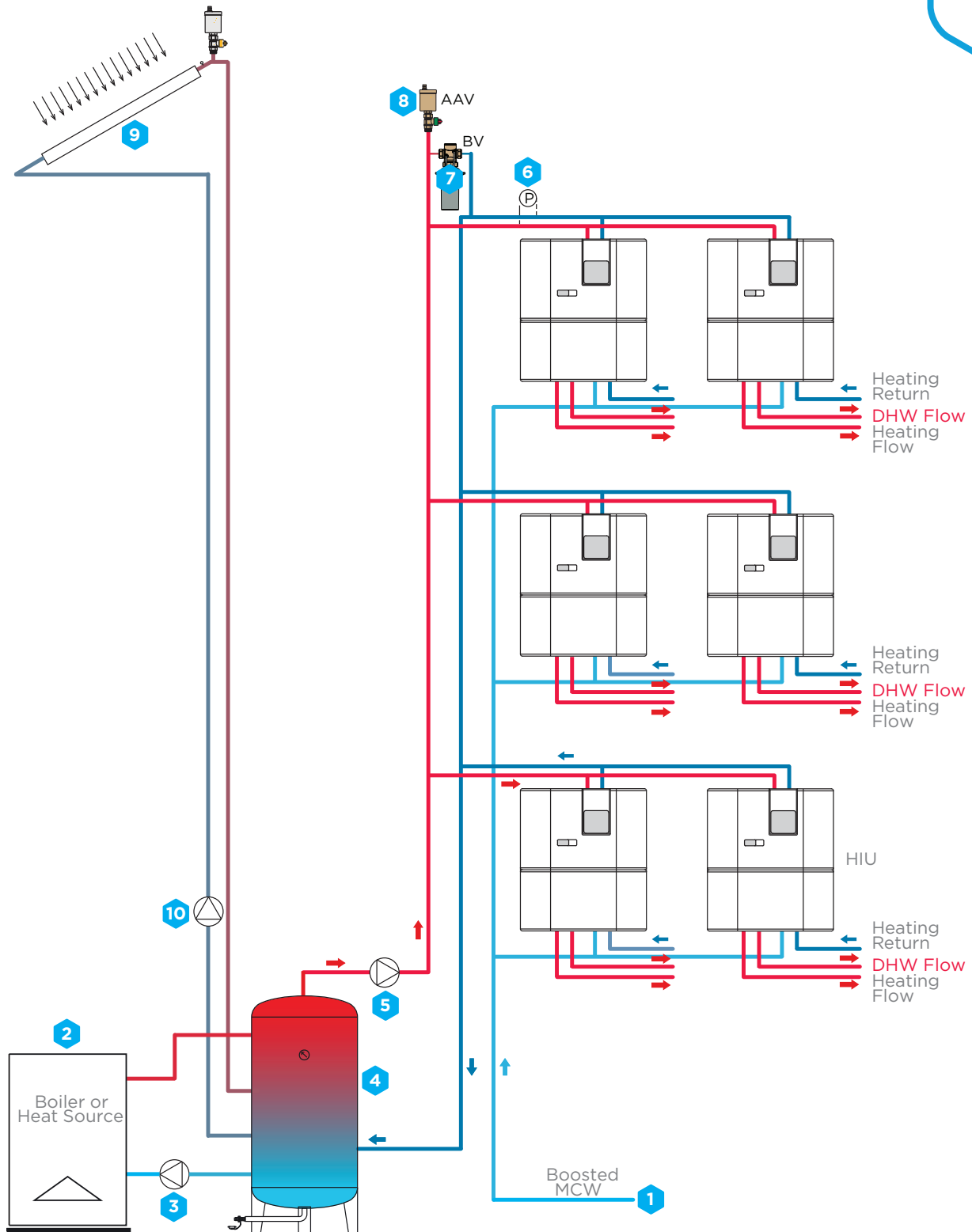

COMPONENTS LIST (SEE PAGES 16-17 FOR DETAILS)

- | | | | |
|---|------------------------------|----|-------------------------|
| 1 | Mains cold water supply | 7 | Bypass |
| 2 | Boiler | 8 | Automatic air vent |
| 3 | Shunt pump | 9 | Solar thermal collector |
| 4 | Buffer tank | 10 | Solar pump station |
| 5 | Primary pump | | |
| 6 | Differential pressure sensor | | |

TYPICAL SYSTEM COMPONENTS

1. MAINS COLD WATER SUPPLY

A minimum mains cold water supply of 0.5 bar is required for the Ideal Logic HIUs. Hot water outlets such as thermostatic showers or outlets fitted with thermostatic mixing valves may require higher pressures to operate correctly.

In tall multi-floor buildings the required cold water pressure will be achieved by a boosted main water supply with pressure reducing valves set to the required pressure on each floor branch.

2. BOILER

Boilers today must be as efficient as possible to reduce carbon emissions to a minimum.

Solar heating or heat pumps can improve the overall efficiency and reduce the size of the boiler required.

Typical boilers are gas condensing boilers, multi stage boilers, a combined heat and power (CHP) unit or a biomass boiler. Low carbon heat sources such as solar heating, heat pumps or CHP units are more efficient when operated with low return water temperatures.

The correct design and sizing of the space heating emitters whether radiator or underfloor heating can help to reduce the return water temperature as much as possible. If domestic hot water is drawn off for baths and showers this will cause a large drop in the heating water return temperature.

3. SHUNT PUMP

The pump on the primary circuit used to circulate water between the boiler and buffer tank is a constant speed constant flow pump.

The purpose of the shunt pump is to ensure that the boiler(s) always have sufficient water flow when in operation, and are therefore not at risk of overheating.

The flow rate in the primary circuit must not be less than the total flow in all secondary circuits fed from the buffer tank.

4. BUFFER TANK

A suitably sized calorifier or buffer tank can provide a thermal store of hot water enabling smaller sized boilers to be run for longer period to combine solar heating and reduce the number of stops and starts of the boiler.

The buffer tank must be designed to achieve stratification of the water, usually by a tall tank design which allows constant temperatures within the tank.

If renewables are not included the return water can be directed back to the boiler bypassing the thermal store.

The buffer tank serves as an energy store, providing for short term, high load demands for hot water.

Without this store of hot water, the boiler may be unable to react with sufficient speed to the heating load imposed by temporary high demand for hot water.

A buffer tank may not be required on large projects, since the distribution pipework can act as a buffer volume of hot water and accommodate large load changes in domestic hot water use. However, in most cases a buffer vessel improves system performance.

Individual hot water storage cylinders in each apartment perform a similar function of having a store of domestic hot water readily available and an equalisation in the demand for heat.

To effectively integrate renewable energy sources, the buffer tank should be an elongated vertical cylinder with primary and secondary flow pipes located near the top of the tank, whilst primary and secondary return pipes are located near the bottom.

The boiler should be controlled so as to maintain the specified heating water flow temperature at a point two thirds of the way down the height of the buffer tank. This creates an adequate store of water for heating during period of high demand, whilst allowing space for cooler return water at the base of the tank.

Since the buffer tank or apartment storage cylinder does not contain hot water but merely the heating water that will be used to heat the domestic hot water, there is no need to worry about anti-stratification measures.

The cooler area at the base of the tank can therefore be used to introduce water heated from renewable sources such as heat pumps or solar energy.

5. PRIMARY PUMP

The primary pump should be variable speed to take advantage of pump energy savings when the heating system is operating at part load.

Pump speed should be controlled such that there is always sufficient pressure available to satisfy the most remote HIU(s).

The individual Ideal Logic HIU brochures contain Kv values for the primary heating side of the HIU through the heat exchanger.

NOTE: Ensure that the pressure differential generated by the pump does not exceed the pressure limitations of the valves inside the HIU. Please refer to individual brochures for details.

6. DIFFERENTIAL PRESSURE SENSOR

A differential pressure sensor installed across main flow and return heating pipes of the most remote HIU(s) will minimise pump energy consumption and ease the commissioning process.

7. BYPASS

A by-pass located at the top of the primary system riser will provide a route for flow under minimum load conditions and there is no demand for primary flow.

A reverse acting differential control valve (RADPCV) will under normal system operating conditions be closed. However, when the system is under very low or no flow conditions, the RADPCV will open as the differential pressure rises and will provide a flow typically between 5 to 10% of the maximum system flow rate.

The flow through the by-pass should be as close as possible to the minimum limit advised by the pump manufacturer.

By locating the reverse acting differential control valve close to the differential pressure sensor, the setting of the valve can easily be determined.

8. AUTOMATIC AIR VENT

Automatic air vents should be fitted at the top of risers where air may collect in pockets and short dead legs. The removal of air will improve the efficiency of the system.

FLUSHING AND COMMISSIONING PROVISIONS

The features shown are as recommended in BSRIA Application Guide AG 1/2001.1 Pre-commission Cleaning of Pipework Systems.

Following the principles set out in the BSRIA Guide AG 1/2001.1 Pre-commission Cleaning of Pipework Systems, each type of HIU should be treated as a terminal unit fed from the main heating system pipework.

In accordance with the guide, all Ideal HIUs are provided with a flushing drain cock should flushing be required.

Available as an accessory for the Ideal HIUs is an 'H' flushing bypass valve arrangement which screws directly into the two isolating ball valves on the flow and return to the central boiler plant.



The flushing bypass will enable the main system pipework to be flushed and cleaned whilst the HIU remains isolated.

The ball valves contain blanking ports for measuring differential pressure if fitted with pressure test point.

It is possible that some debris could be carried into the hot water side of the plate heat exchanger with the incoming mains cold water supply.

It is recommended that a strainer is installed on the mains cold water supply to the domestic hot water heat exchanger to collect any debris which may be present.



FLUSHING AND COMMISSIONING PROVISIONS

Pressure test points are required to verify the differential pressure (pressure points supplied as standard).

Each Logic HIU requires a minimum differential pressure in order to function correctly. Pressure tappings across the main heating circuit flow and return pipes will enable the available pressure to be measured and confirmed as adequate.

SYSTEM SIZING

HIU SELECTION

The schematic opposite shows a typical system with central boiler plant, roof mounted solar thermal collectors, buffer storage and Ideal Logic HIUs.

PIPE SIZING FROM THE CENTRAL BOILER PLANT

Pipe diameters from the central boiler plant to each HIU must be sized to accommodate the maximum heating and diversified hot water demands served by that pipe.

The maximum heating demand is relatively predictable, this being the summation of the calculated heating loads for each of the apartments.

However, the estimation of maximum hot water demand is less obvious. It is extremely unlikely that all of the hot water taps in all of the apartments will be open simultaneously therefore some allowance for the diversity in usage is required.

Simultaneous demand is only predictable when the pattern of usage in each apartment might reasonably be expected to be identical, such as in a hall of residence where the occupants are expected to get up at exactly the same time and return in the evening at exactly the same time.

For groups of apartments occupied by families with different occupations and lifestyles, the load pattern is likely to be very different.

In such cases, peak demand periods in each apartment are unlikely to occur simultaneously for the simple reason that people will get up at different times in the morning and come in from work at different times in the evening, hence the expected peak simultaneous hot water demand will be lower.

This explains why surveys of hot water consumption for multiple apartments often show peak simultaneous demand values significantly less than might be expected.

The design standards in some European countries where district heating is more established reflect this within their respective diversity factors for example, the Danish Standard DS439.

DIVERSITY FACTOR

The degree of diversity for multiple dwellings is expressed as a “coincidence factor” and is defined as:

$$F = \frac{DFR}{MFR}$$

WHERE

F = coincidence or diversity factor

DFR = design flow rate for hot water outlets - l/s

MFR = max. possible flow rate for hot water outlets - l/s

No HIUs	DIVERSITY
1	1
2	0.6194
3	0.4765
4	0.3988
5	0.3490
6	0.3139
7	0.2876
8	0.2670
9	0.2504
10	0.2366
11	0.2250
12	0.2151
13	0.2064
14	0.1988
15	0.1920
16	0.1860
17	0.1805
18	0.1756
19	0.1710
20	0.1670
21	0.1631
22	0.1596
23	0.1563
24	0.1533
25	0.1504
26	0.1478
27	0.1453
28	0.1429
29	0.1407
30	0.1386

No HIUs	DIVERSITY
31	0.1366
32	0.1347
33	0.1329
34	0.1312
35	0.1296
36	0.1280
37	0.1265
38	0.1251
39	0.1238
40	0.1224
41	0.1212
42	0.1200
43	0.1188
44	0.1177
45	0.1166
46	0.1156
47	0.1148
48	0.1136
49	0.1127
50	0.1118
51	0.1109
52	0.1100
53	0.1092
54	0.1084
55	0.1076
56	0.1069
57	0.1061
58	0.1054
59	0.1047
60	0.1040

No HIUs	DIVERSITY
61	0.1034
62	0.1027
64	0.1015
65	0.1009
67	0.0998
68	0.0992
69	0.0987
70	0.0981
71	0.0976
72	0.0971
73	0.0966
74	0.0961
75	0.0956
76	0.0952
77	0.0946
78	0.0942
79	0.0939
80	0.0934
81	0.0930
82	0.0926
83	0.0922
84	0.0918
85	0.0914
86	0.0910
87	0.0907
88	0.0903
89	0.0899
90	0.0896
91	0.0892
92	0.0889
93	0.0886
94	0.0882
95	0.0879
96	0.0876
97	0.0872
98	0.0870
99	0.0867
100	0.0864

EFFECT OF DIVERSITY FACTORS

THE SIMPLE SYSTEM ILLUSTRATES THE EFFECTS FOR DIVERSITY. IT ASSUMES THAT EACH APARTMENT IS IDENTICAL WITH A:

Heat load	3 kW
DHW load	50 kW
Heating ΔT	10°C
DHW primary ΔT	55°C

Copper tube	3 kW
Pipe diameter based on:	50 kW
Pressure loss per meter length	340 Pa/m

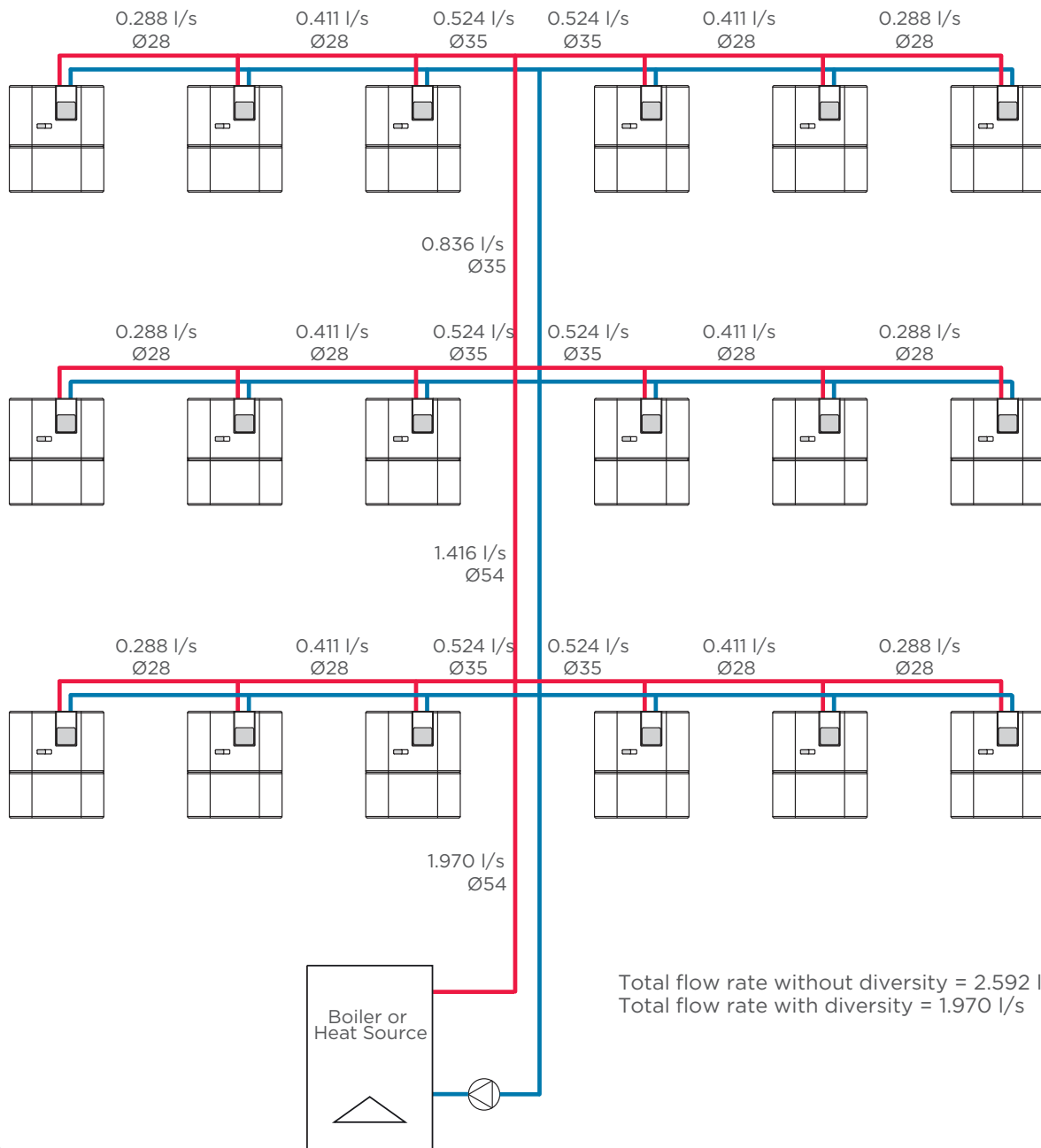

FLOW RATE CALCULATION

Using the diversity factor from the chart, the maximum design flow rate for each section of heating pipe can be determined.

The flow rate through each pipe must be capable of delivering the peak heating demand for the apartment being served plus the peak simultaneous diversified demand for domestic hot water.

$$Q_T = (F * Q_{HW}) + (Q_{HTG})$$

WHERE

F = Coincidence or diversity factor

Q_T = Total design flow rate - l/s
 Q_{HW} = water flow rate to meet peak domestic hot water demand - l/s

Q_{HTG} = Water flow rate required to meet peak space heating demand - l/s

The quantity of hot water to heat the domestic hot water Q_{DHW} can be calculated from the equation:

$$Q_{DHW} = \frac{P_{HW}}{4.2 * \Delta T_{DH}}$$

SIZING THE CENTRAL BOILER PLANT

The energy output of the central boiler plant does not need to match the calculated peak heating and domestic hot water demand as the HIU has hot water priority.

Peak demand should only occur for a relatively short time period during peak domestic hot water consumption, which is unlikely to be sustained for a prolonged period.

There are two factors which enable the energy source to be reduced:

- When domestic hot water is being consumed, each HIU prioritises the domestic hot water circuit temporarily stopping the flow of water to the space heating circuit. This does not affect the space heating temperature within the apartment since domestic hot water is only consumed for a short period of time
- A buffer tank provides a thermal store to enable the system to supply a large amount of energy for a short period

The buffer tank cools during peak demand and return to the design temperature when the peak demand has passed.

The central boiler plant can therefore be sized to meet the total heating load PHTG plus an additional allowance to re-heat the buffer tank within one hour P_{BUFFER}. The Ideal Indirect with a storage cylinder in each apartment acts in a similar manner as a buffer vessel for the domestic hot water dealing with peak demand and reheating within short time period.

A buffer vessel should still installed as part of the centralised part to deal with peak demand for energy as previously described.

WHERE

P_{HW} = Energy required in kW for all HIU domestic hot water
 Δ_{T_{DH}} = Design temperature drop across the central boiler plant side of the heat exchanger during hot water production - typically 50 °C - 75 °C flow, 25 °C return.

4.2 = Specific heat factor - kJ / kg °K

The quantity of hot water for space heating Q_{HTG} can be calculated from the equation:

$$Q_{HTG} = \frac{P_{HTG}}{4.2 * \Delta T_{HTG}}$$

WHERE

P_{HTG} = energy required in kW for all apartments - typically 3 to 10 kW each

Δ_{T_{HTG}} = design temperature drop across the central boiler plant side - typically 30 °C - 75 °C flow, 45 °C return.

ENERGY REQUIRED TO HEAT BUFFER VESSEL

The quantity of hot water to heat the contents of the buffer vessel within one hour can be calculated from the equation:

$$P_{BUFFER} = \frac{V * 4.2 * \Delta T_{DH}}{3,600}$$

WHERE

V = volume of buffer vessel - litre

For a duration less than one hour substitute the number of seconds for 3,600.

BUFFER VESSEL SIZING.

The buffer vessel should be sized to deal with peak heating and hot water demand sustained over a period of 10 minutes = 600 seconds.

Assuming the boiler plant is controlled to maintain the required heating flow temperature at a point two thirds of the way down the vessel then the required energy flow into the vessel will be for 900 seconds.

$$V = 900 * F * Q_{HW}$$

WHERE

V = volume of buffer vessel - litre

COMMISSIONING AND CHECKS

PRE-COMMISSIONING CHECK

Before commissioning commences check that:

- The pipework installation has been completed, all components are positioned and installed correctly, easily accessible for commissioning and future maintenance and identified correctly

Please refer to CIBSE Commissioning Guide Code W 'Water Distribution Systems'.

- The system has been filled, thoroughly vented and pressure tested
- The system has been flushed and chemically cleaned in accordance with BSRIA Guide BG29/2012 'Pre-commission Cleaning of Pipework'
- The pumps and associated variable speed drives are installed, inspected and tested in accordance with the manufacturer's instructions and are ready to operate
- A closed head pump test has been carried out on each pump and the results plotted on the manufacturer's pump performance graph

BALANCING THE RADIATOR CIRCUITS

The space heating circuit in each apartment will need to be balanced to ensure a comfortable environment for the occupants.

If heated by radiators the flows between radiators will need to be balanced by means of a "temperature balance" whereby the lockshield valves are regulated until the return temperature from each radiator is at approximately the same temperature or at the specified room temperature.

Individual room temperature control will be achieved by fitting thermostatic radiator valves set at the correct temperature.

The only other item that requires flow balancing is the automatic differential by-pass valve.

This can be set by adjusting its flow rate to a value in the range 5-10% of the maximum load flow rate, as recommended by the pump supplier.

THE COMPLETE,
COMPACT,
LOW MAINTENANCE
SOLUTION FOR
INSTANT **HOT** WATER
AND SPACE
HEATING CONTROL.

DESIGNED FOR
COMMUNAL HEATING SYSTEMS

INCLUDING **APARTMENT BUILDINGS** AND **DISTRICT HEATING SC**

INTERNAL **ELECTRONIC CONTROL** U
WITH LCD DISPLAY, ENSUR
MAXIMUM EF

THE **BOILER** RANGE



INTEGRATION WITH **LOW CARBON**
TECHNOLOGY



PLEASE REFER TO THE IDEAL INSTALLATION AND SERVICING MANUAL FOR THE RESPECTIVE LOGIC HIUs.

DOMESTIC HOT WATER CAPACITY TESTING

Having confirmed the temperature, flow and pressure conditions in the main heating system, the hot water output from individual HIUs can be adjusted and tested as required:

- Set the pressure reducing valves on the boosted mains water supply branches to the required value for each apartment i.e. typically 0.5 bar minimum, such that there is sufficient pressure available for each HIU and downstream hot water outlets
- In the index apartment open the number of taps specified by BS6700, check the domestic hot water temperatures
- Open the taps in additional apartments at various points in the building up to the predicted diversified maximum, check the domestic hot water temperatures at all outlets

BALANCING THE PRIMARY SYSTEM

It should be possible to establish maximum and minimum load operating conditions when setting the pump. This test should demonstrate a significant reduction in pump speed at minimum load conditions.

With the system operating at its design temperature, the procedure for carrying out these tests is as follows:

- Ensure that all radiator circuits are set to full flow i.e. all zone control valves, radiator valves are fully open and the thermostatic heads are removed from thermostatic radiator valves
- Open a sufficient number of tap outlets, starting with the most least favoured remote outlets work back towards the most favoured towards the pump, until the measured flow rate through the pump is equal to the calculated maximum load flow rate for the system
- Q_T = total design flow rate for the system
- Measure the differential pressure being generated by the pump by reference to inlet and outlet pressure gauges
- Confirm and record the total flow rate leaving the pump using the flow measurement device installed on the secondary circuit main return pipe
- Record how long it takes to empty the hot water in the buffer vessel (if applicable) at this condition, this should be a minimum of 10 minutes
- Close all tap outlets. Override the controls to force all 2 port heating zone control valves into their fully closed positions
- Measure the differential pressure being generated by the pump is the previous value and re-measure the total flow rate leaving the pump. If the pump is being controlled correctly the pump pressure value should be close to the controlled value at the differential pressure sensor
- This flow rate should be close to the flow rate passing through the by-pass at the top of the riser

UNIT
RING
EFFICIENCY.

SCHEMES.

ARBON
OLOGIES.

INSTANTANEOUS
HOT
WATER.

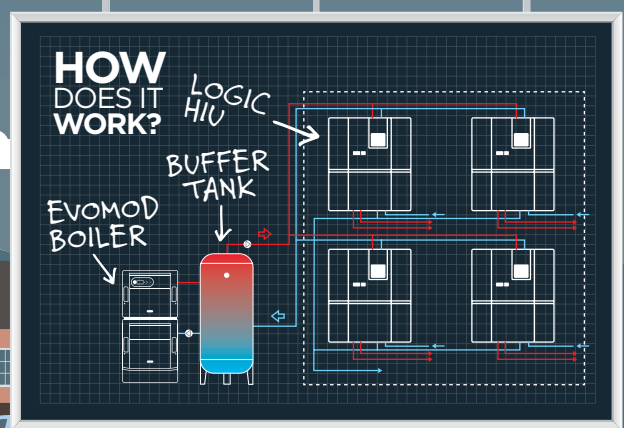



Trusted
heating
solutions.

HERE FOR YOU.

At Ideal, we are committed to delivering the highest levels of customer service. With over a century of experience in the heating industry, we know how important confidence and trust is to our customers.

You can be confident to know that you're partnering with a British manufacturer that's supported by a dedicated national service team, delivering help and advice to you and your customers throughout the year.

NEED HELP?

GET IN TOUCH WITH US TODAY

SALES

Tel: 0844 5436060
Fax: 0844 5436181

TECHNICAL

Tel: 01482 440237 Fax: 01482 498621
commercial.services@idealboilers.com

BOILER TRAINING

WE'VE GOT TRAINING COVERED

Our comprehensive one-day courses can be mixed and matched for individual installation and servicing companies. Each course uses a simple step-by-step approach with hands on training to ensure all aspects of commissioning, servicing, and fault finding can be dealt with quickly and efficiently.

BOOK ONLINE AT:

idealcommercialboilers.com



COMMERCIAL

WE HAVE IT COVERED.

P.O. Box 103, National Avenue
Kingston Upon Hull, HU5 4JN

T: 0844 5436060

F: 0844 5436181

idealcommercialboilers.com

 [@idealboilers](https://twitter.com/idealboilers)  [Ideal Boilers](https://www.linkedin.com/company/ideal-boilers)



APPROVAL

These appliances are certified to G.A.D. 90/396 and B.E.D. 92/42 Safety and Performance Directives for gas boilers. Ideal Commercial Boilers pursues a policy of continuous improvement in design and performance of its products and reserves the right to vary specification without notice. Statutory rights of the consumer are not affected.

PLEASE NOTE:

The information in this brochure was correct at the time of going to print. Ideal Commercial Boilers reserve the right to make any modifications to product specifications or any other details, without prior notification. For further clarification, please enquire in writing to the head office address (address below).