

# EVO S CONDENSING BOILER



PRODUCT & FLUE GUIDE



[idealcommercialboilers.com](http://idealcommercialboilers.com)

 [@idealcommercial](https://twitter.com/idealcommercial)  [Ideal Boilers](https://www.linkedin.com/company/ideal-boilers)  [@idealcommercialboilers](https://www.facebook.com/idealcommercialboilers)





---

Ideal Commercial Boilers is the UK's market leader of high efficiency commercial heating solutions.

Operating from its Hull manufacturing plant and offices since 1906, Ideal Commercial Boilers is one of the few true British manufacturers left in the heating industry.

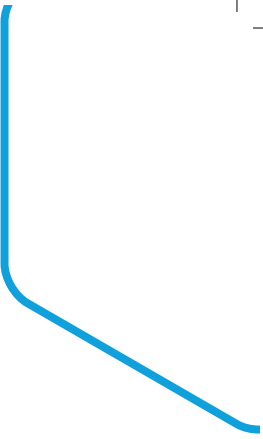



<b>2</b>	Introduction
<b>4-13</b>	EVO S 50 - 135kW
<b>14-16</b>	EVO S Cascade 50 - 540kW
<b>17-20</b>	EVO S Flue Options
<b>21</b>	Flue Resistances
<b>22-23</b>	Flue Types
<b>24-30</b>	Guide to Flue Installation & Regulation
<b>31</b>	Condensate Pumps
<b>33</b>	Ideal Training & Support





# EVO S

50 - 135kW

---

**5** YEAR  
WARRANTY\*



NOx  
CLASS 6

\*5 year warranty subject to Terms and Conditions. 5 years parts and labour warranty available subject to being commissioned by Ideal Boilers. Must be fitted with a Low Loss Header or Plate Heat Exchanger. Terms and conditions available at [www.idealcommercialboilers.com/downloads](http://www.idealcommercialboilers.com/downloads)



**EVO S**

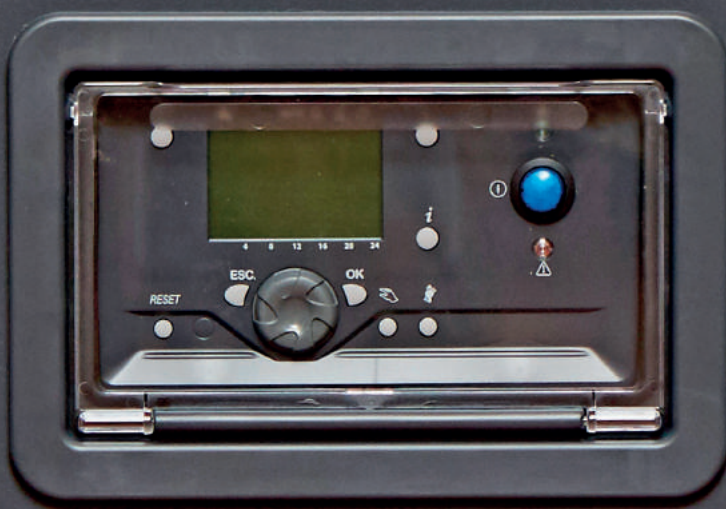

# EVO S

50 - 135kW

50, 70, 95, 115 and 135kW, EVO S combines the latest stainless steel heat exchanger technology with straightforward installation and maintenance. 50, 70 and 95kW models can be easily converted to run on LPG.

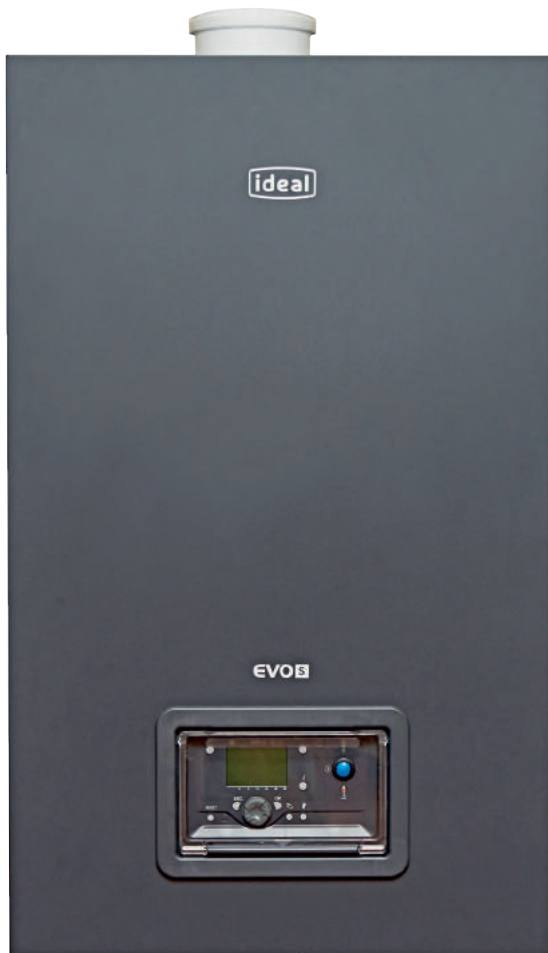

## FEATURES & BENEFITS

- 5 year parts and labour warranty\*
- Stainless steel heat exchanger
- Up to 108.9% net efficiency (fully condensing)
- Up to 5:1 turndown
- Compact - one width & height for easy siting
- Simple controls interface with large backlit display
- Low height frame and header kits
- Simple to maintain using quick release internal water and gas couplings
- NOx <40mg/kWh (Class 6)
- Must be installed with a suitable method of system protection, such as a Low Loss Header or Plate Heat Exchanger



## DIMENSIONS & CLEARANCES

BOILER	DIM A
50	477
70, 95	574
115	692
135	800

All dimensions in mm

The following minimum clearances must be maintained for operation and servicing:

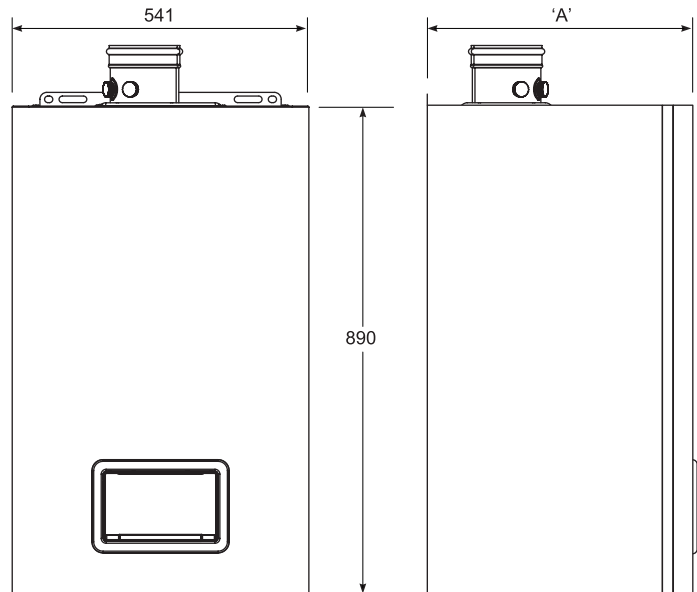
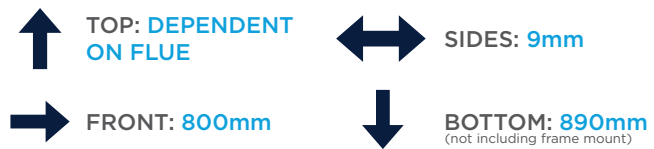

## BOILER ASSEMBLY

### INTERNAL VIEW

(50kW MODEL SHOWN)

#### KEY

1. Ignition Electrode
2. Ignitor Unit
3. Safety Thermostat
4. Fan
5. Gas Valve
6. Controls Housing
7. Control Panel With Protective Cover

## PERFORMANCE DATA

### EVO S 50 - 135kW

MODEL			50	70	95	115	135	
Boiler Output (non-condensing) Mean 70°C (Nat Gas & LPG 50-95, Nat Gas only 115 & 135)	Max	kW	56.4	69.9	95.7	119.5	134.0	
	Min	kW	11.5	17.1	19.0	23.9	26.8	
Boiler Output (condensing) Mean 40°C (Nat Gas & LPG 50-95, Nat Gas only 115 & 135)	Max	kW	61.0	76.8	104.5	129.5	146.0	
Boiler Input Max Rate (Nat Gas & LPG 50-95, Nat Gas only 115 & 135)	Net	kW	58.0	72.1	98.5	123.0	137.9	
	Gross	kW	64.4	80.0	109.3	136.5	151.6	
Gas Rate, Nat Gas (G20)	Max rate	m³/hr	6.1	7.6	10.4	13.0	14.6	
Gas Rate, LPG (G31)	Max rate	m³/hr	2.4	3.0	4.0	N/A	N/A	
Flue Gas Flow Rate, Nat Gas	Max Rate	m³/hr	79	98	135	168	189	
Flue Gas Flow Rate, LPG	Max Rate	m³/hr	77	96	128	N/A	N/A	
CO <sub>2</sub> (±0.1%), Nat Gas	Max Rate	%	9.2					9.0
	Min Rate	%	8.8					8.6
CO <sub>2</sub> (±0.1%), LPG	Max Rate	%	10.4			N/A	N/A	
	Min Rate	%	10.0			N/A	N/A	
NO <sub>x</sub> with O <sub>2</sub> = 0%	Weighted	mg/kWh	35	35	34	36	35	
Efficiency	Seasonal	%	96.13	95.50	96.02	95.95	95.75	
	*SEDBUK 2009	%	89.2	88.8	89.1	89.1	89.0	
Operating Temperature	Max	°C	85					



## GENERAL DATA

### EVO S 50 - 135kW

MODEL		50	70	95	115	135
Gas Supply		G20 to G31			G20	
Gas Supply Connection		G1"				
Flow Connection		G1 ¼"				
Return Connection		G1 ¼"				
Max Pressure (sealed system)	Bar (psi)	4.0 (58)				
Electricity Supply		230V - 50Hz				
Power Consumption	W	138	96	160	206	263
IP Rating		IP24D				
Nominal Flue Size (concentric)	mm	80/125	100/150			
Condensate Drain	mm	24				
Water Content	l	5.0	9.0	10.2	12.8	15.3
Dry Weight	Kg	60	90	95	100	125
Noise emission @1m: @maximum modulation	dB(A)	59.7	57.3	58.5	61.6	59.3
Noise emission @1m: @minimum modulation	dB(A)	35.8	33.5	34.3	35.4	36.8

## OPTIONAL KITS

BOILER	EVO S
Modulating Sequencer kit	✓
Programmable Room Thermostat kit	✓
Outside sensor kit	✓
Tank Sensor kit	✓
Room sensor kit	✓
Multi boiler low height frame & header kits	✓
Clip In kit: +1 circuit, up to 2 per Boiler	✓
LPB Bus Communication Module	✓

## SUGGESTED ENGINEERING SPECIFICATION

The Suggested Engineering Specification is wording designed for specifiers to copy and paste into their specifications to ensure inclusion of Ideal Commercial boilers.

### OVERVIEW

The boilers must be fully automatically controlled, wall mounted, fanned, super-efficient condensing appliances utilising a stainless steel heat exchanger and be suitable for connection to a sealed water system.

### CONTROLS

The condensing boilers must have connectivity for common types of BMS. Additional modules may be used for volt free connectivity. Where no BMS is present a modulating sequencer must be available.

The boiler must be fully modulating with a 5:1 turndown ratio and have control features enabling set point adjustment, heating circuit control of one constant temperature and one DHW circuit or 2 constant temperature circuits, and safety lock out parameters including fault diagnosis for both boiler and external components such as sensors or pumps.

Boiler capabilities must include, with the use of external components, frost protection, weather or room compensation and system pump control.

### FLUE

The condensing boilers must be suitable for use with a room sealed flue or open flue applications including C13, C33 and B23 classifications. The combined flue outlet and air inlet must be situated on the top of the boiler.

### HYDRAULIC

The condensing boiler must be suitable for connection to a sealed water system. All hydraulic connections including flow return and condensate drain must be located on the bottom of the boiler. Hydraulic connections must be uniform across the outputs available in the range to ensure ease of installation and maintenance in mixed output cascades. The boiler must have a maximum operating pressure of 4 bar and be suitable for heating and indirect hot water systems.

### DIMENSIONS

The condensing boiler range must have a universal compact width and height across the range to ensure mixed output cascades maintain the same universal configuration. Maximum permitted wall area of 0.49m<sup>2</sup>.

### MOUNTING

The condensing boilers can be installed either on the wall or into a prefabricated floor mounted frame. Wall brackets must be located at the top of the boiler and visible from the front to aid installation.

### EFFICIENCY

The condensing boilers are capable of high seasonal efficiencies with a minimum requirement of 96.02% and low NO<sub>x</sub> emissions no greater than 36mg/kWh.

Models <70kW must have a Seasonal Space Heating Energy Efficiency of A.

### APPROVALS

The boiler must be tested and certified to; EN 483, EN 677, PREN 15420, BSEN 15417, BSEN 656, BSEN 60335-2-102, BSEN 55014-1 and BSEN 55014-2 for use with Natural Gas. Boilers are certified to meet the requirements of the EC Gas Appliance Directive, Boiler Efficiency Directive, EMC and Low Voltage Directive.

The manufacturer must be ISO 9001 accredited.

### SPECIFICATION

The boiler will be capable of flow rates for common systems using 11°C to 20°C temperature differentials.

### CASCADE

The boiler must be configurable up to 4 boilers (max 540kW) in cascade using a prefabricated frame and header kit.

### WARRANTY

The boiler must be available with a 5 year warranty.

## SYSTEM TEMPERATURE

### DIFFERENTIALS

Flow rates for common systems using either 11°C, 20°C or 25°C temperature differentials are given in the table below.

BOILER	FLOW RATE (L/S)			HYDRAULIC RESISTANCE (MBAR)		
	11°C	20°C	25°C	11°C	20°C	25°C
EVO S 50	1.2	0.7	0.5	1157	350	224
EVO S 70	1.5	0.8	0.7	909	275	176
EVO S 95	2.1	1.1	0.9	1273	385	246
EVO S 115	2.6	1.4	1.1	1620	490	314
EVO S 135	2.9	1.6	1.3	1700	580	380

## CONTROL KITS

### MODULATING SEQUENCER KIT.

Controls up to 15 boilers for cascade operation.

### OUTSIDE SENSOR KIT.

Provides weather compensation directly or with Programmable Room Thermostat kit.

### TANK/CYLINDER SENSOR KIT.

Provides DHW temperature control.

### ROOM SENSOR KIT.

Provides room temperature control.

### CLIP IN KIT.

Each Clip In give an additional circuit, up to 2 per boiler. Clip In also gives Volt Free run and fault signal.

### LPB BUS COMMUNICATION MODULE.

1 module per boiler to enable sequencer.

## FLUE SYSTEMS

A comprehensive range of flue kits are available from Ideal Commercial Boilers including horizontal and vertical concentric and open flue options.

**When installing EVO S boilers with concentric flue (horizontally or vertically) the Ideal Commercial flue system must be used.**

The resistance of flue components, together with the maximum flue resistance each boiler can work against, may be used to calculate the total flue resistance of the system, and to determine if they are acceptable to run on the boiler.

Multiple boilers may be installed with a common flue header which should be designed and supplied by a specialist flue company. BS6644 and IGEM UP10 provide guidance on design and the drainage of condensate from flue stack and headers. Condensate from a flue stack and header must be collected and drained before entering the boiler.

**For Ventilation requirements please refer to the installation manual and BS6644.**

# SINGLE BOILER

## INSTALLATIONS

WHEN INSTALLING A SINGLE EVO S BOILER, THERE ARE WALL HUNG AND FRAME HUNG OPTIONS.

### WALL HUNG SINGLE BOILER WITH LOW LOSS HEADER

A simple pipe kit is available for location directly underneath the boiler. When using this pipe kit, the boiler must be mounted to the wall directly so the combined weight of the boiler and low loss header must be accounted for (boiler + 15kg).

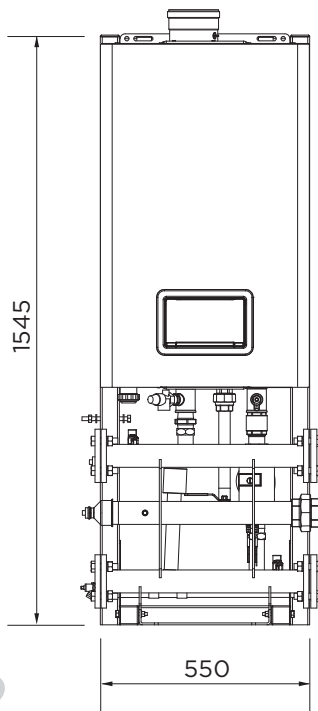
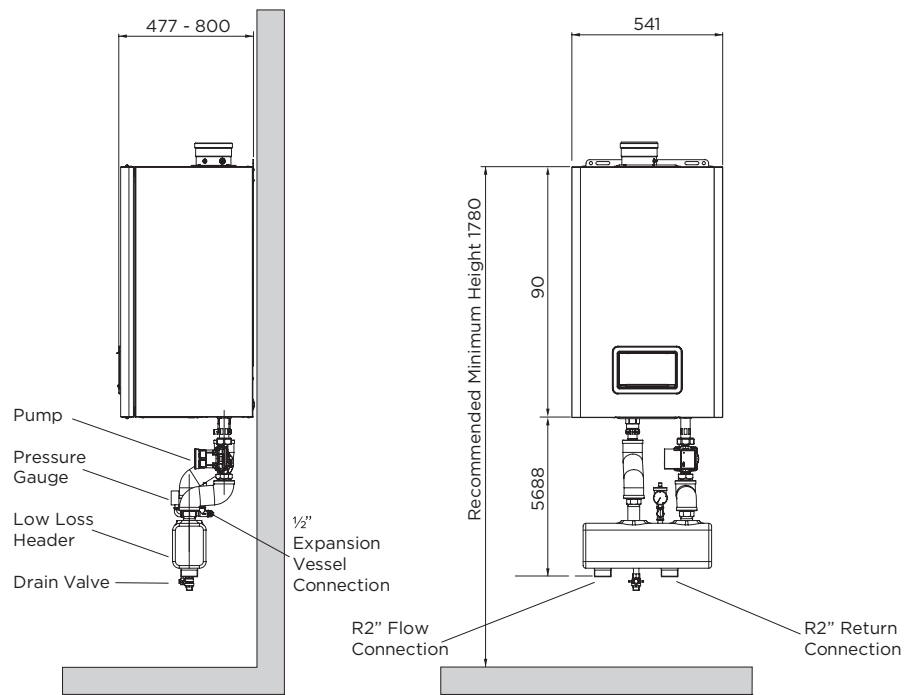

### FRAME HUNG SINGLE BOILER WITH LOW LOSS HEADER

An alternative solution is to use a frame and header kit and a low loss header for installing a single boiler.

FRAME & HEADER KITS	RATING	HEIGHT (mm)	LENGTH (mm)	DEPTH (mm)	DN FLANGE SIZE	CONCENTRIC FLUE
UIN219468	50kW	1545	550	642	DN50	80/125
	70kW	1545	550	642	DN50	100/150
UIN219472	95 - 135kW	1545	550	642	DN80	100/150

# SYSTEM LAYOUT

## TYPICAL SYSTEM BOILER LAYOUT

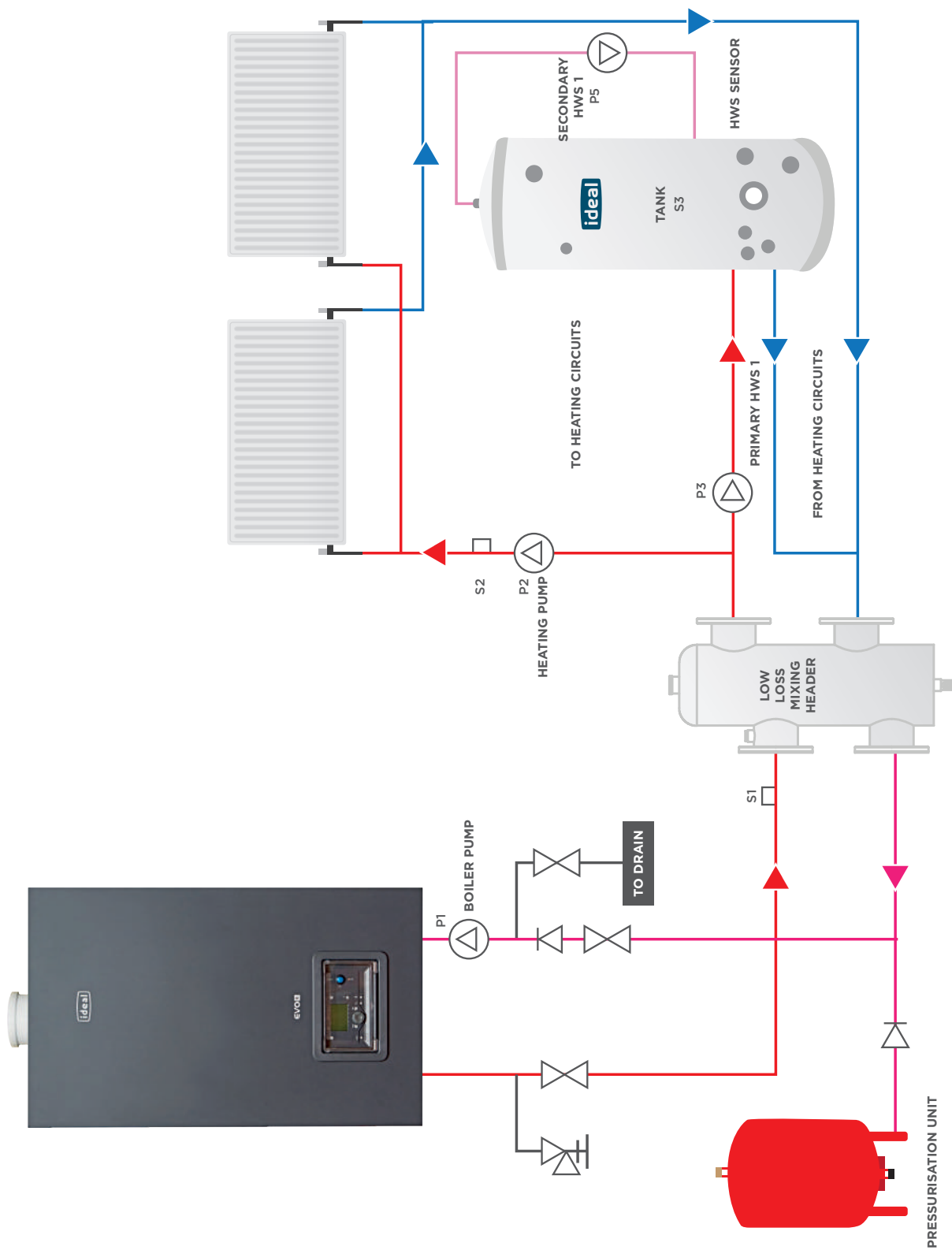



# EVO S CASCADE

## LOW HEIGHT FRAME & HEADER KITS



### BOILER LOW HEIGHT FRAME AND HEADER KITS

The Frame and Header Kits are suitable for modular (cascade) boiler installations, and are available up to a maximum output of 540kW.

Kits include flow & return headers with gas header and all with fixing brackets. For easy connection flexible stainless steel pipe and connections are supplied together with pressure relief valves, boiler shut off valves and drain cock. An optional low loss header completes the installation, available to suit either DN50 or DN80 pipe kit assemblies.

Appropriately sized ErP modulating shunt pumps are also included. Flow, return and low loss headers together with the flexible boiler connections are all pre insulated.



### AVAILABLE OPTIONS

	MODELS	SIZE
2 boilers	50, 70	DN50
2 boilers	95 - 135	DN80
3 boilers	50, 70	DN50
3 boilers	95 - 135	DN80
4 boilers	50, 70	DN50
4 boilers	95 - 135	DN80

For full details of all configurations & specifications, please refer to the installation manual at [www.idealcommercialboilers.com/downloads](http://www.idealcommercialboilers.com/downloads)

**Please note, the EVO S boilers are to be ordered separately.**

## FRAME & HEADER KITS

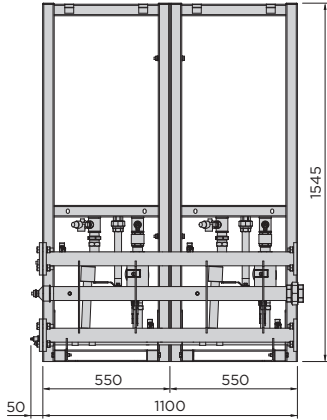

### 2 X EVO S 50 - 135kW

FRAME & HEADER KITS	RATING	HEIGHT (mm)	LENGTH (mm)	DEPTH (mm)	DN FLANGE SIZE	CONCENTRIC FLUE
UIN219469	50kW	1545	1100	642	DN50	80/125
	70kW	1545	1100	642	DN50	100/150
UIN 219473	95 - 135kW	1545	1100	642	DN80	100/150

Measurements are without boilers attached.

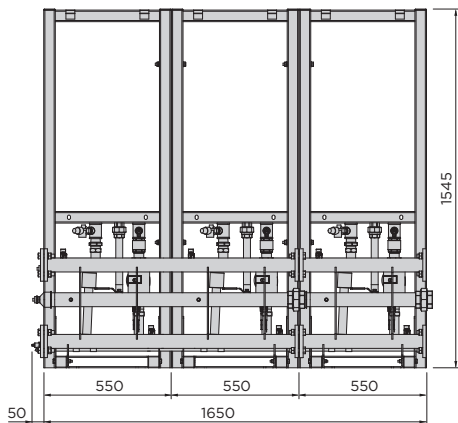

### 3 X EVO S 50 - 135kW

FRAME & HEADER KITS	RATING	HEIGHT (mm)	LENGTH (mm)	DEPTH (mm)	DN FLANGE SIZE	CONCENTRIC FLUE
UIN219470	50kW	1545	1650	642	DN50	80/125
	70kW	1545	1650	642	DN50	100/150
UIN219474	95 - 135kW	1545	1650	642	DN80	100/150

Measurements are without boilers attached.

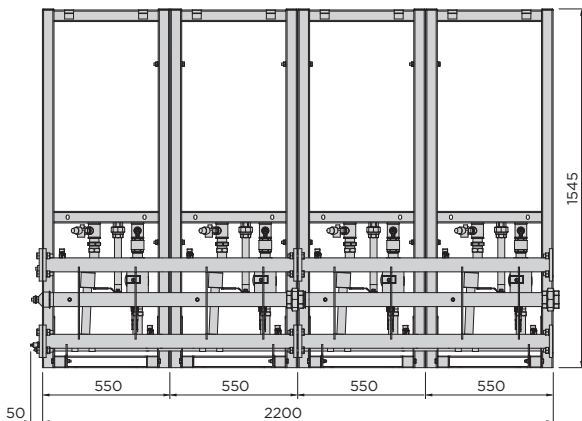

### 4 X EVO S 50 - 135kW

FRAME & HEADER KITS	RATING	HEIGHT (mm)	LENGTH (mm)	DEPTH (mm)	DN FLANGE SIZE	CONCENTRIC FLUE
UIN219471	50kW	1545	2200	642	DN50	80/125
	70kW	1545	2200	642	DN50	100/150
UIN219475	95 - 135kW	1545	2200	642	DN80	100/150

Measurements are without boilers attached.

All dimensions in mm

# SYSTEM LAYOUT

## TYPICAL SYSTEM BOILER LAYOUT

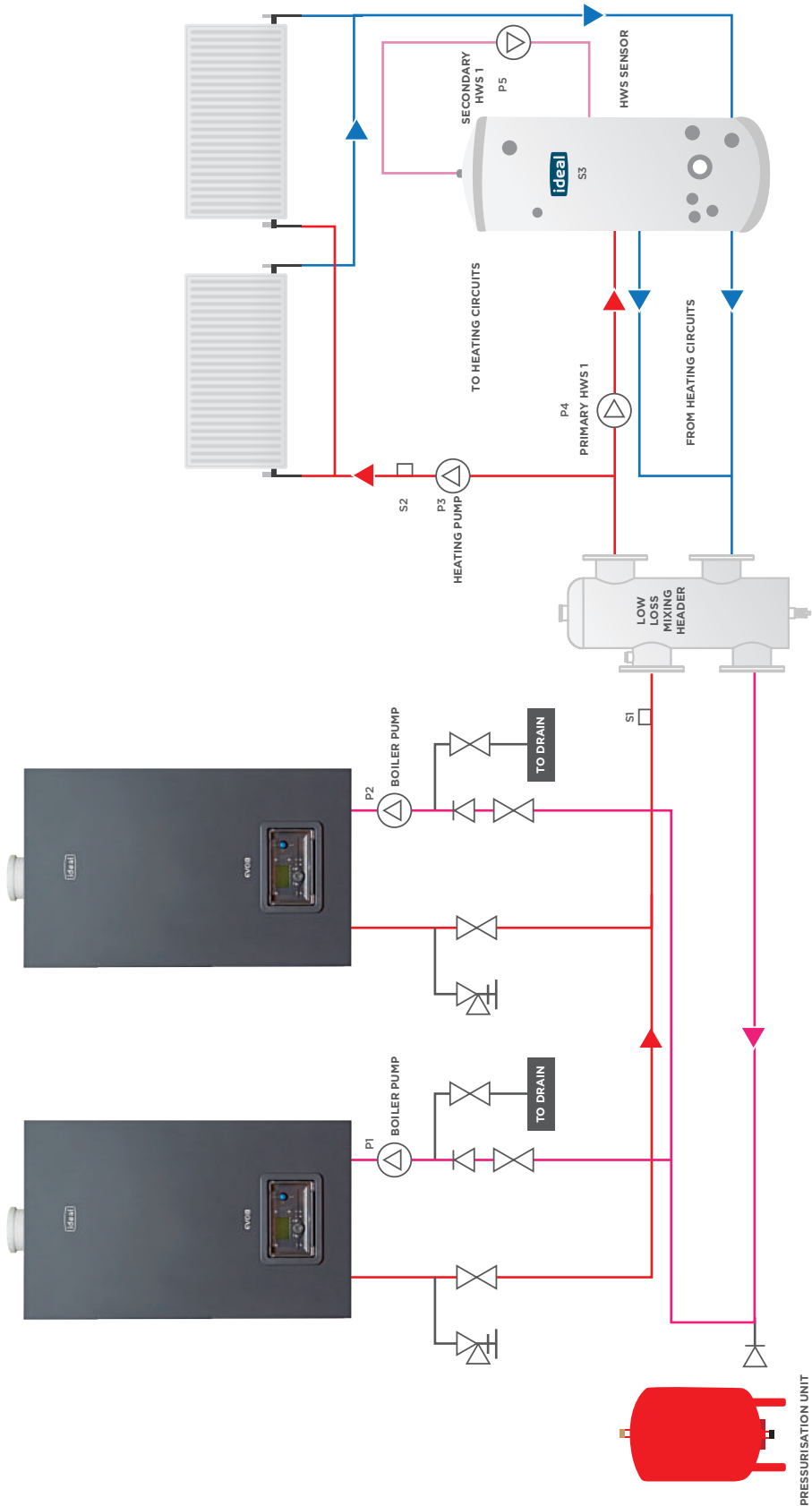

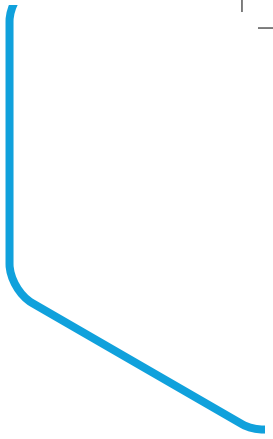

# EVO S FLUE OPTIONS



# CONCENTRIC FLUE OPTIONS (C TYPE)

## HORIZONTAL WALL FLUE KIT

### EVO S HORIZONTAL CONCENTRIC FLUE APPLICATION. MAXIMUM LENGTHS

Model	50		70		95		115	135
Fuel	Nat Gas	LPG	Nat Gas	LPG	Nat Gas	LPG	Nat Gas	Nat Gas
Max Flue Length (m)	12.2	10.2	12.5	12.5	12.5	12.5	10.5	8.5
Flue Size	80/125		100/150					
Wall Flue Kit Part No	213267		213269					

Measurements include terminal (0.6m) and 1 x 90° elbow (1.6m 80/125, 1.9m 100/150).

#### CONTENTS

**1** Boiler adapter + screws (x6)  
(not required to fit to EVO S)

**2** 90° elbow  
**3** Terminal  
**4** Locking collars (x2)  
**5** Wall plates (x2)

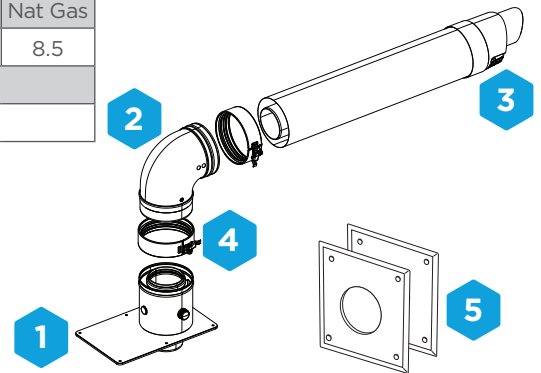

## VERTICAL ROOF FLUE KIT

### EVO S VERTICAL CONCENTRIC FLUE APPLICATION. MAXIMUM LENGTHS

Model	50		70		95		115	135
Fuel	Nat Gas	LPG	Nat Gas	LPG	Nat Gas	LPG	Nat Gas	Nat Gas
Max Flue Length (m)	11.2	9.2	11.2	11.2	11.2	11.2	9.2	7.2
Flue Size	80/125		100/150					
Wall Flue Kit Part No	213264		213266					

Measurements include terminal (1.2m).

#### CONTENTS

**1** Boiler adapter + screws (x6)  
(not required to fit to EVO S)

**2** Terminal  
**3** Locking Collar  
**4** Finishing plates (x2)  
**5** Bracket

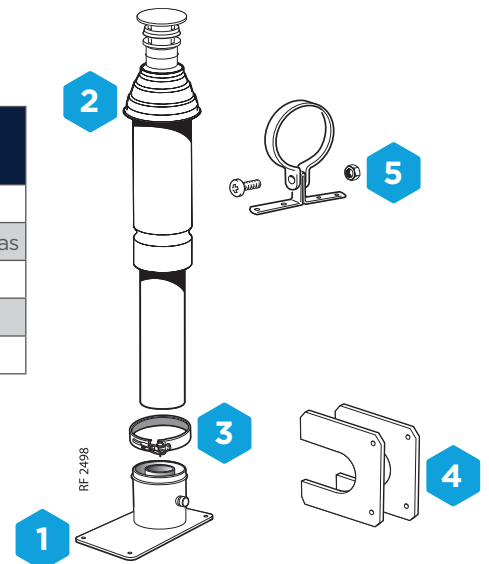



# OPEN FLUE OPTIONS (B TYPE)

EVO S VERTICAL CONCENTRIC FLUE APPLICATION. MAXIMUM LENGTHS					
Model	50	70	95	115	135
Max flue length (m)	20	83	50	24	40
Flue Size	80/125	100/150			
Open Flue Kit Part No	219530	219531			

Extension and termination of flue after Open Flue Kits must be completed by independent flue specialist.

**To comply with CE certification, EVO S boilers must be fitted with:**

- **B type flues must use the air inlet grille.**
- **C type flues must use a complete EVO S flue.**

## FLUE KIT ACCESSORIES

ACCESSORY		FLUE TYPE	PART NO.			
			80/125	100/150	80	100
1	90° elbow (concentric)	C	213259	213263	N/A	N/A
2	45° elbow (concentric)	C	213260	213258	N/A	N/A
3	90° elbow	B	N/A	N/A	158773	158774
4	45° elbow (pair)	B	N/A	N/A	158775	158776
5	Flat Weather Collar	B/C	152611	152612	158780	158780
6	Pitched Weather Collar	B/C	152609	152610	158779	158779
7	1m Extension (concentric)	C	213261	213262	N/A	N/A
8	1m Extension (pair)	B	N/A	N/A	158771	158772
Wall bracket		B/C	202242	202243	N/A	N/A

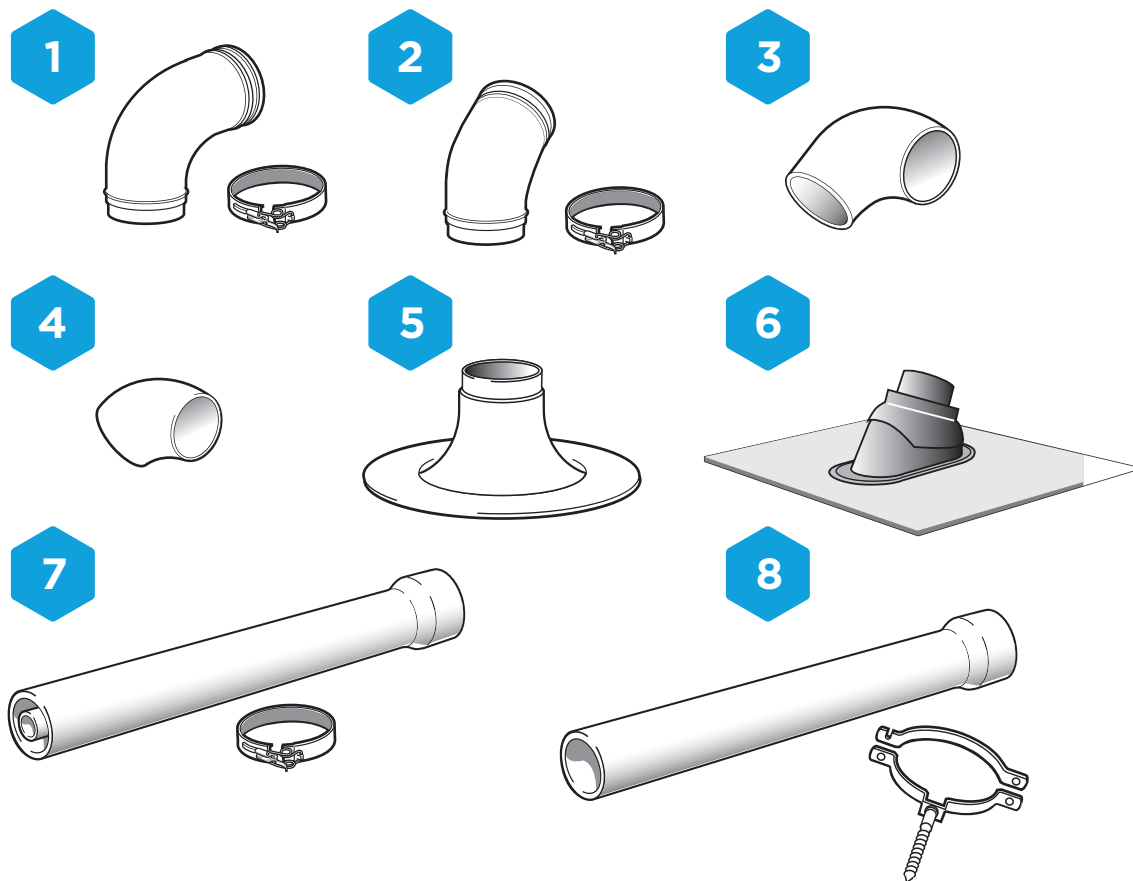

# FLUE RESISTANCES

## FLUE SYSTEMS

For concentric flue systems with elbows fitted, use the table to correct the maximum flue extension capability. Alternatively use the table to design the flue system, deducting the individual resistance of components from the maximum pressure drop allowed in the flue for that boiler. The maximum pressure drop allowed in the flue is given below.

### PERMISSIBLE FLUE LENGTH

The maximum permissible flue lengths for each model are shown in Table 1 below, these lengths are inclusive of the terminal resistance. The value shown is the maximum available length for extension. The equivalent length of elbows is shown in Table 2.

TABLE 1

MAX PERMISSIBLE EQUIVALENT FLUE LENGTH (INC TERMINAL RESISTANCE) (METRES)						
Flue Size	CONCENTRIC HORIZONTAL		CONCENTRIC VERTICAL		OPEN FLUE	
	80/125	100/150	80/125	100/150	80	100
Model						
50	12.2	-	11.2	-	20	-
50 LPG	10.2	-	9.2	-	20	-
70	-	12.5	-	11.2	-	83
70 LPG	-	12.5	-	11.2	-	83
95	-	12.5	-	11.2	-	50
95 LPG	-	12.5	-	11.2	-	50
115	-	10.5	-	9.2	-	24
135	-	8.5	-	7.2	-	40

TABLE 2

EQUIVALENT LENGTH OF ELBOWS (METRES)				
Size	CONCENTRIC		OPEN FLUE	
	80/125	100/150	80	100
45°	0.85	1.25	0.45	0.60
90°	1.60	1.90	1.00	1.00

### EXAMPLES OF FLUE LENGTH CALCULATION

MODEL	FLUE TYPE	MAX PERMISSIBLE EQUIVALENT LENGTH (TABLE 1) (M)	ELBOWS				MAX PERMISSIBLE STRAIGHT LENGTH (M)
			TYPE	EQUIVALENT LENGTH (TABLE 2)(M)	NO	TOTAL EQUIVALENT LENGTH (M)	
50	80/125 Concentric Horizontal	12.20	90	1.60	1	1.60	10.60
50 LPG	80/125 Concentric Vertical	9.20	45	0.85	2	1.70	7.50
50	80 Open Flue	20.00	90	1.00	2	2.00	18.00
70	100/150 Concentric Horizontal	12.50	90	1.90	1	1.90	10.60
115	100/150 Concentric Vertical	9.20	45	1.25	2	2.50	6.70
135	100 Open Flue	40.00	90	1.00	2	2.00	38.00

# FLUE TYPES

Before ventilation can be sized we need to identify the type of flue system.

**Type B** - Open flue: takes air from the plant room (adequate ventilation must be available).

**Type C** - Room sealed: takes air from outside

We also need to know the classification of the room type.

- Boiler house - a dedicated building for the installation of boilers and ancillary plant.
- Boiler room - a dedicated room within a building for the installation of boilers and ancillary plant.
- Enclosure - space in which a boiler(s) is installed, which is not large enough to permit access for work other than maintenance via external access.
- Plant room - a room in a building that houses plant and machinery.
- Open space - e.g. in a warehouse.

## CLASSIFICATION OF TYPE B FLUES

Appliance type	Primary definition	Natural draught	Fan down stream of heat exchanger	Fan upstream of heat exchanger
B open flue	B1- appliance with a draught diverter	B11	B12 B14*	B13
	B2 - appliance without draught diverter	B21	B22	B23

\*Appliance fan also downstream of draught diverter

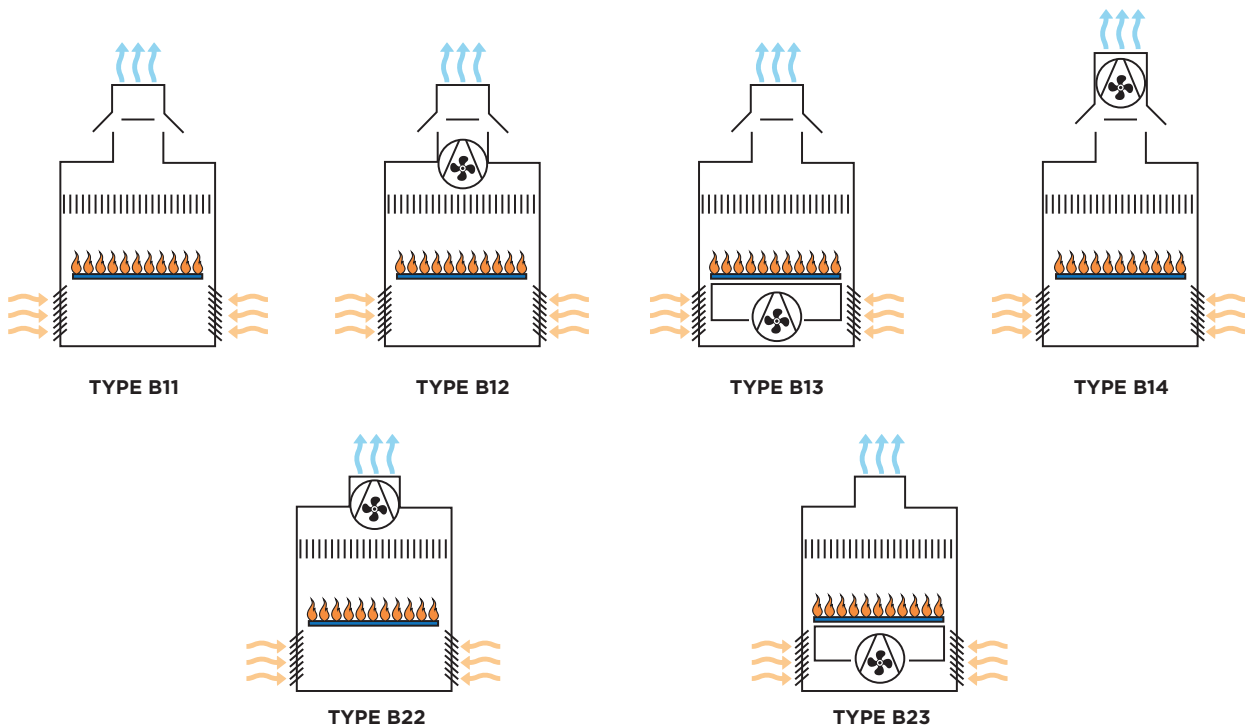

Where 2 or more gas fired boilers are connected to a common natural draught flue, the boilers must be installed in the same room and have the same type of burner system. A gas fired boiler and a solid fuel or biomass boiler must not discharge into the same flue. A gas fired boiler and a liquid fired fuel boiler can discharge into the same flue providing they are both installed in the same room and are force draught.

Appliance type	Primary definition	Natural draught or fan draught		
		Natural draught	Fan down stream of heat exchanger	Fan upstream of heat exchanger
C type Room sealed	C1- appliances with a horizontal balanced flue/inlet air ducts to outside atmosphere.	C11*	C12	<b>C13*</b>
	C2 - appliance flue connects to a common duct system for multi-appliance installations (the common duct system is part of the building)	C21	C22	C23
	C 3 - appliance with vertical balanced flue/inlet air ducts to outside atmosphere.	C31	<b>C32*</b>	<b>C33*</b>
	C4 - appliance with flue system that connects to a common duct system e.g. 'U' duct flue system.	C41	C42	C43
	C5 - appliance with a non-balanced flue/inlet air duct system.	C51	C52	C53
	C6 - appliance sold without a flue system	C61	C62	C63
	C7 - appliance connected to a vertical flue to outside atmosphere with the air ducts in the loft (vertex)	C71	C72	C73
	C8- appliance with a non-balanced flue system with an air supply from outside atmosphere and flued into a common duct system.	C81	C82	C83

\*Appliance fan also downstream of draught diverter

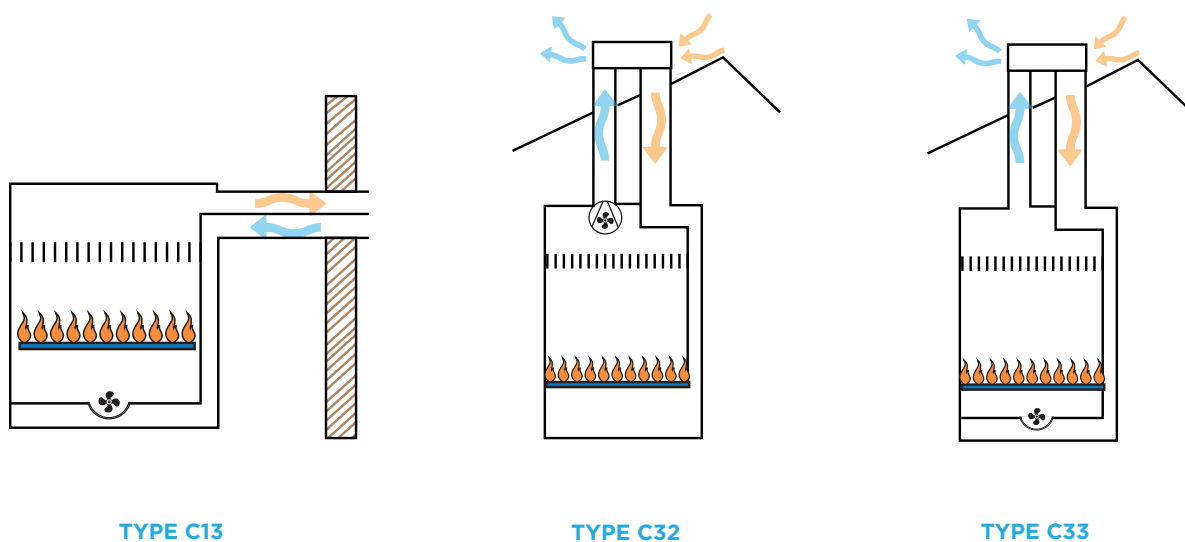



# GUIDE TO FLUE INSTALLATION & REGULATIONS

There are many different regulations relating to flues and ventilation. This document will not cover all of them but assists in obtaining information and guidance, and provide useful and practical information.

This guide looks at common standards used to determine the requirements for flue and ventilation installation requirements and should not be used as a sole reference for flue regulations. Please also remember to use the installation and service manual for specific guidance for each boiler and to refer to the relevant standards.

## COMMERCIAL BOILERS (70kW – 1.8MW)

**BS6644** Specification for the installation and maintenance of gas-fired hot water boilers of rated inputs between 70 kW (net) and 1.8 MW (net) (2nd and 3rd family gases). In IE refer to I.S. 820.

**IGEM UP10** Installation of flued gas appliances in industrial and commercial premises.

**Building Regs Part J** Combustion appliances and heat storage, gives advice on how to comply with Building Regulations.

**Clean Air Act (1956 Amendment)** A UK Parliament Act passed in response to London's Great Smog of 1952.

The Act introduced a number of measures to reduce air pollution, especially by introducing 'smoke control areas' in some towns and cities in which only smokeless fuels could be burned. By shifting homes' sources of heat towards cleaner coals, electricity, and gas, it reduced the amount of smoke pollution and sulphur dioxide from household fires. Reinforcing these changes, the Act also included measures to relocate power stations away from cities, and for the height of some chimneys to be increased.

The Act was an important milestone in the development of a legal framework to protect the environment.

Although smog is no longer an issue, more recent editions of the Clean Air Act have maintained control of emissions and heights of flues.

## WHEN SHOULD I USE COMMERCIAL FLUE REQUIREMENT LEGISLATION AND GUIDANCE?

BS5440 covers domestic installations up to 70kW net input, however if an appliance is to be installed in a factory location even if under 70kW then the commercial requirements of IGEM UP10 & BS6644 must be adopted.

Similarly if a cascade boiler installation is fitted and the total input exceeds 70kW then the commercial flues and ventilation should be adopted.

## WHAT IS GUIDANCE AND WHAT IS MANDATORY?

**British Standards** are a mandatory requirement. The approved documents offer guidance on how to comply and are not legally binding unless the manufacturer of the appliance stipulates them in the installation manual. It is prudent however to follow them because they would likely be used in a court of law as the minimum expected by a competent person to install a safe system.

**Building Regs** are a mandatory requirement as set out in Government legislation.

**IGEM Documents** offer guidance in the same way as British Standards. However these have been set and adopted by a board of industry experts and represent current best practice and are aligned with National/International legislation and standards.

**Clean Air Act** - This is a mandatory requirement as set out in Government legislation.

**Gas Safety (Installation and Use) Regulations 1998** - These are mandatory and set out the requirements for safe installations.

### CLEAN AIR ACT - THE FACTS

The Act applies to gas (and other fuels) fired appliance installations generally but with specific requirements for installations exceeding 333 kW net heat input including approval of the height of the chimney by the Local Authority. The essential requirements are that flue discharges are not to cause a nuisance to others or be a hazard to health.

In 1956 there was a clean air act memorandum that stated appliances with gross input of 150kW must terminate vertically. This has no foundation in law and was not written for modern high efficiency products. To this effect the current guidance suggests that all installations from 135kW net input that wish to terminate horizontally should be subject to a risk assessment which can be found in IGEM UP10.

#### All installations are subject to the Clean Air Act:

Installations below 333kW net heat input can terminate horizontally at low level subject to a risk assessment and complying with all other clearance distances as defined in IGEM UP10.

- Appliance inputs greater than 333kW net need prior approval from the Local Authority with position of flue termination agreed by them.
- No terminal fitted to natural draught flues should be less than 170mm.
- Terminal positions for fanned or natural draught flues shall be clear of obstructions and openings into buildings. Wall terminations shall be directed away from the building.
- Vertical outlets must be the minimum required above the roof level.
- Any horizontal outlet below 2m must be guarded and a minimum of 300mm above ground level.

# TERMINATION POSITIONS APPLIANCES OVER 70kW NET INPUT

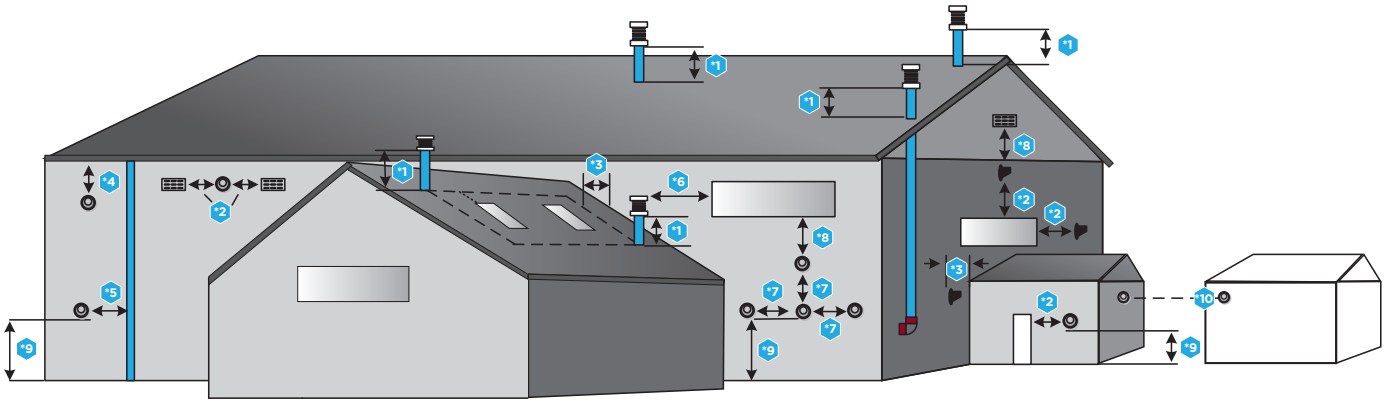

**Key to Diagram:**

- \*1 - Minimum termination height for ridged and flat roofs.
- \*2 - Minimum horizontal termination distance from openings i.e. doorways, windows, ventilation grilles, etc.
- \*3 - Minimum horizontal termination distance from adjacent walls or obstructions.
- \*4 - Minimum distance to be 200 mm for fan assisted appliances, 300 mm for room sealed natural draught appliances, see IGEM UP10 .
- \*5 - Minimum distance to be 150 mm, see IGEM UP10.
- \*6 - Minimum termination distance from openings i.e. doorways, windows, ventilation grilles, etc.
- \*7 - Minimum distance of centres of flue terminal, see manufacturer's instructions.
- \*8 - Minimum distance below terminal or opening 2.5 m.
- \*9 - Minimum 300mm above the ground. If less than 2m subject to a risk assesment (available from IGEM UP10).
- \*10 - Opposing a terminal or flat surface.

**SEE IGEM 10 FOR FURTHER DETAILS**

1, 3 & 6 Minimum Height of Termination Located on a roof								
Example Inputs	70kW	80kW	100kW	120kW	150kW	200kW	240kW	300kW
Natural Draught	600mm	615mm	645mm	676mm	722mm	798mm	859mm	950mm
For other natural draught appliances use Distance = 1.5225 (net heat input kW) + 493.43								
Fanned Draught	300mm	327mm	380mm	433mm	513mm	646mm	753mm	913mm
For other fan draught appliances use Distance = 2.6644 (net heat input kW) +113.49								
For all sloped roofs over 20 degree pitch the terminal must be 1.5m away								
If the flue termination is within 2.5m of an adjacent structure then these heights above the structure will apply								

2 Minimum Horizontal Termination To Openings Into Buildings (side or above)								
Example Inputs	70kW	80kW	100kW	120kW	150kW	200kW	240kW	300kW
Open Flue and Fanned Draught	1500mm	1600mm	1790mm	1975mm	2265mm	2740mm	3120mm	3690mm
For other open flue fan draught inputs use Distance = 9.5156 x (net heat input) + 833.91								
Room Sealed Fanned Draught	600mm	675mm	820mm	960mm	1180mm	1540mm	1830mm	2265mm
For other room sealed fan draught inputs use Distance = 7.232 x (net heat input) + 93.708								
The minimum distance below in all cases is 2500mm								

10 Room Sealed Fanned Draught Minimum Horizontal Termination To Opposing Walls/Terminals								
Example Inputs	70kW	80kW	100kW	120kW	150kW	200kW	240kW	300kW
Opposing Flat Surface	1000mm	1231mm	1694mm	2156mm	2850mm	4006mm	4931mm	6319mm
For other inputs use Distance = 23.126 x (net heat input) - 618.84								
Opposing Terminal	600mm	675mm	820mm	960mm	1180mm	1540mm	1830mm	2265mm
For other inputs use Distance = 19.32 x (net heat input) + 647.59								

# VENTILATION REQUIREMENTS OF COMMERCIAL BOILERS OVER 70kW NET INPUT

## ROOM SEALED APPLIANCES, TYPE C IN PLANT ROOMS

FLUE TYPE	VENTILATION DIRECT TO OUTSIDE AIR (cm <sup>2</sup> per kW net heat input)	
	HIGH	LOW
(TYPE C)	2	2

## OPEN FLUED APPLIANCES, TYPE B IN PLANT ROOMS (ADDITIONAL RECOMMENDATIONS)

Natural Ventilation cm <sup>2</sup> kW (net) heat input for open flue boilers located in a boiler house				
	(A) Boiler House	(B) Enclosure	Summer usage* greater than 50% up to 75%	Summer usage* greater than 75% up to 100%
High	2	5	+1	+2
Low	4	10	+1	+2

\*for boilers in use for more than 50% of the time during the summer months, additional ventilation needs to be added to those in columns A and B

## OPEN FLUED APPLIANCES, TYPE C IN PLANT ROOMS (ADDITIONAL RECOMMENDATIONS)

Natural Ventilation cm <sup>2</sup> kW (net) heat input for open flue boilers located in a boiler house					
	(A) Boiler House	(B) Enclosure		Summer usage* greater than 50% up to 75%	Summer usage* greater than 75% up to 100%
		To a room or internal space	Direct to outside air		
High	2	10	5	+1	+2
Low	2	10	5	+1	+2

\*for boilers in use for more than 50% of the time during the summer months, additional ventilation needs to be added to those in columns A and B

For further information, please refer to:

- Manufacturer's instructions
- IGEM UP10
- BS6644

- High level ventilation openings shall be located as high as is reasonably practicable and preferably within 15% of the building height from the ceiling.
- Low level ventilation openings shall be within 1m of the floor for Natural Gas and within 250mm of the floor for LPG.
- For LPG it is preferable that low level ventilation openings are located at floor level.
- Ventilation to an internal space is not generally recommended unless a Risk Assessment has been completed.
- The air supplied for boiler room ventilation shall be such that the maximum temperature within the boiler house is:
  - 25°C at floor level (or 100mm above floor level)
  - 32°C at mid level (1.5 m above floor level)
  - 40°C at ceiling level (or 100mm below ceiling level)

## MECHANICAL VENTILATION

- Mechanical ventilation can be a combination of mechanical inlet and outlet or mechanical inlet and natural ventilation outlet.
- The fans shall be selected and controlled so as to not cause a negative pressure (relative to the outside atmosphere) developing in the boiler room.
- Interlocked to the gas appliance.

## MINIMUM QUANTITY OF MECHANICAL VENTILATION

Mechanical ventilation m <sup>3</sup> /hr per kW net heat input				
	(A) Min inlet air m <sup>3</sup> /hr	(B) Difference between inlet and extract air <sup>†</sup> m <sup>3</sup> /hr	Summer usage <sup>††</sup> greater than 50% up to 75%	Summer usage <sup>††</sup> greater than 75% up to 100%
Boiler(s) with draught diverter	2.8	2.07 ±0.18	+0.72	+1.44
Boiler(s) without draught diverter <sup>†††</sup>	2.6	1.35 ±0.18	+0.72	+1.44

<sup>†</sup>inlet air minus ventilation 2.8 - 2.07 = 0.73m<sup>3</sup>/hr  
<sup>††</sup>For boilers in use for more than 50% of the time during the summer months, additional mechanical ventilation needs to be added to those columns A and B  
<sup>†††</sup> with or without draught stabilisers

## WATER TREATMENT

### IMPORTANT

The application of any other treatment to this product may render the guarantee of Ideal Boilers Invalid.

Ideal Boilers recommend Water Treatment in accordance with the Benchmark Guidance Notes on Water Treatment in Central Heating Systems.

If water treatment is used Ideal Boilers recommend only the use of Scalemaster Gold 100, Fernox, MB-1, Adey MCI, Sentinel-X100, CALMAG CM100 inhibitors and associated water treatment products, which must be used in accordance with the manufacturers' instructions.

### NOTES

1. It is most important that the correct concentration of the water treatment products is maintained in accordance with the manufacturers' instructions.
2. If the boiler is installed in an existing system any unsuitable additives MUST be removed by thorough cleansing. BS 7593:2006 details the steps necessary to clean a domestic heating system.
3. In hard water areas, treatment to prevent lime scale may be necessary - however the use of artificially softened water is NOT permitted.
4. Under no circumstances should the boiler be fired before the system has been thoroughly flushed.

### FOR FURTHER INFORMATION CONTACT:

**Fernox Alent plc**  
 Forsyth Road, Sheerwater, Woking, Surrey  
 GU21 5RZ  
 Tel: +44 (0) 870 601 5000

**Sentinel Performance Solutions**  
 7560 Daresbury Park  
 Daresbury, Warrington  
 Cheshire  
 WA4 4BS  
 Tel: 0800 389 4670  
 www.sentinelprotects.com

**Scalemaster Water Treatment Products**  
 Emerald Way, Stone, Staffordshire  
 ST15 OSR  
 Tel: 01785 811636

**Calmag Ltd.**  
 Riverview Buildings  
 Bradford Road, Riddlesden,  
 Keighley, West Yorkshire  
 BD20 5JH  
 Tel: +44 (0) 1535 210 320

**Adey Professional Heating Solutions**  
 Gloucester Road,  
 Cheltenham GL51 8NR  
 Tel: +44 (0) 1242 546700



## DOMESTIC BOILERS (UP TO 70kW)

### BS5440

Flues and ventilation for gas appliances of rated input not exceeding 70 kW net (1st, 2nd and 3rd family gases). Specification for the installation and maintenance of ventilation provision for gas appliances. In I.E refer to I.S. 813.

## FLUE TERMINATION POSITION

Due to the high efficiency of these boilers plumbing will occur. For this reason vertical termination is recommended, and in any case, terminal positions which could cause problems should where possible be avoided.

The information below is extracted from BS5440 Pt. 1 and is for boilers with heat inputs not exceeding 70kW nett, and the latest Building Regulation Part J. Detailed reference should still be made to these standards. In IE refer to I.S. 813:2002.

CONCENTRIC WALL TERMINAL POSITIONS	MINIMUM SPACING
A. Below an opening (1)	300mm
B. Above an opening (1)	300mm
C. Horizontally to an opening (1)	300mm
D. Below gutters, soil pipes or drain pipes	75mm
E. Below eaves	200mm
F. Below balcony or car port roof	200mm
G. From a vertical drain pipe or soil pipe	150mm
H. From an internal or external corner or to a boundary alongside the terminal	300mm
I. Above ground, roof or balcony level	300mm
J. From a surface or a boundary facing the terminal	600mm
K. From a terminal facing the terminal	1200mm
L. From an opening in the car port into the building	1200mm
M. Vertically from a terminal on the same wall	1500mm
N. Horizontally from a terminal on the same wall	300mm
CONCENTRIC ROOF TERMINAL POSITIONS	
Directly below an opening, air brick, windows, etc.	300mm
Below plastic/painted gutters	500mm*
Below painted surface	500mm*
Below eaves or balcony	500mm
From wall	1000mm
Below Velux window	2000mm
Above or side of Velux window	600mm

\* May be reduced to 300mm if a shield fitted.

(1) An opening here means an openable element, such as an openable window, or a fixed opening such as an air vent. However, in addition, the outlet should not be nearer than 150mm (fanned draught) to an opening into the building fabric formed for the purpose of accommodating a built in element, such as a window frame.

If the terminal is fitted less than 500 mm below plastic gutters, painted eaves or any other painted surface then an aluminium shield at least 1m long should be fitted to protect the surface. For positioning of open flue terminals reference should be made to BS. 5440 Pt. 1. In IE refer to I.S. 813:2002

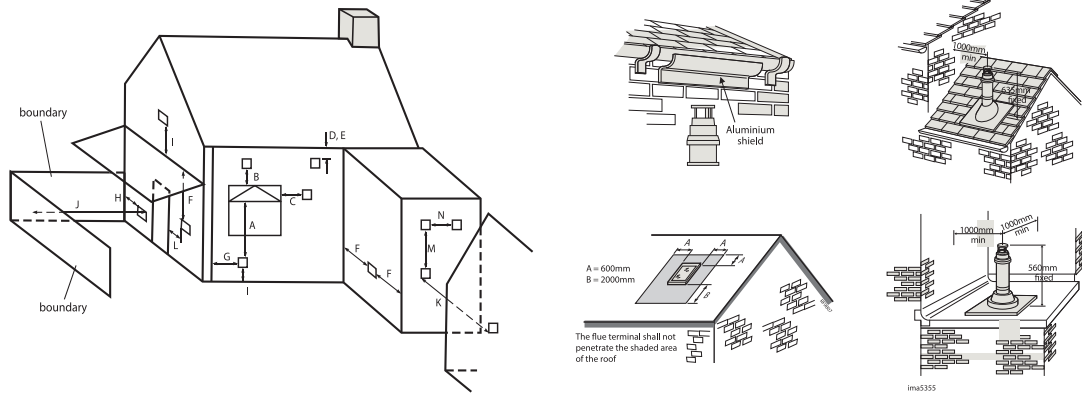

Heat inputs in excess of 70kW nett.

For boiler installations with total heat inputs in excess of 70kW nett, reference should be made to BS6644. In ie refer to I.S. 820:2000.

## VENTILATION

The ventilation requirements of these boilers is dependant on the type of flue system used, and their heat input. All vents must be permanent with no means of closing, and positioned to avoid accidental obstruction by blocking or flooding.

### EVO S 50

Detail reference should be made to BS5440 Pt. 2. In IE refer to the current edition of I.S. 813.

The following notes are for general guidance only: If installed as a room sealed appliance in a room or internal space, then no purpose provided ventilation is required. If installed as an open flued appliance in a room or internal space then a permanent air vent is required. The sizes given below are for vents directly communicating with outside air. For other situations refer to BS. 5440 Pt. 2. In IE refer to the current edition of I.S. 813.

BOILER SIZE	50
Minimum vent free area (cm <sup>2</sup> )	255

If installed in a compartment, then permanent air vents are required at high and low level. These vents may communicate direct to outside air, or to a room/internal space. If to a room/ internal space, it must itself be adequately ventilated as above.

### EVO S VENTILATION REQUIREMENTS (NOT EXCEEDING 70KW NET INPUT) WHEN INSTALLED IN A COMPARTMENT

	ROOM SEALED APPLICATION - MIN. VENT FREE AREA (CM <sup>2</sup> )		OPEN FLUE APPLICATION - MIN. VENT FREE AREA (CM <sup>2</sup> )	
	TO A ROOM OR INTERNAL SPACE	TO OUTSIDE AIR	TO A ROOM OR INTERNAL SPACE	TO OUTSIDE AIR
Boiler Size	50	50	50	50
High Level	580	290	580	290
Low level	580	290	1,160	580

# CONDENSATE PUMPS

The condensate pump is designed to collect and remove condensate and can be used with high efficiency condensing boilers.

TECHNICAL INFORMATION	
Maximum flow rate	440 litres/hour
Electrical supply	230V AC / 50-60 Hz 0.8amps
Alarm contact	NC 4 Amps resistive
Overheat protection	130 °C
Tank Capacity	2.0 Litres
Maximum vertical head	4.5m
Maximum horizontal length	30m

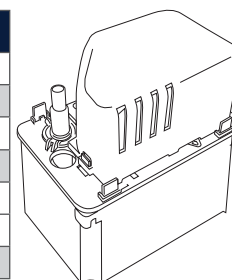

IDEAL COMMERCIAL BOILERS - CONDENSATE PUMP COMPATIBILITY	
BOILER	COMPATIBLE
EVOMAX - 30 - 150kW	✓
EVO S - 50 - 135kW	✓
IMAX XTRA - 80 - 280kW	✓
IMAX XTRA EL - 320 - 1240kW	✓
EVOMOD - 250 - 1000kW	✓
EVOJET - 150 - 1450kW	✓

## TYPICAL CONDENSATE SYSTEM

### TERMINATION TO DRAIN / GULLEY

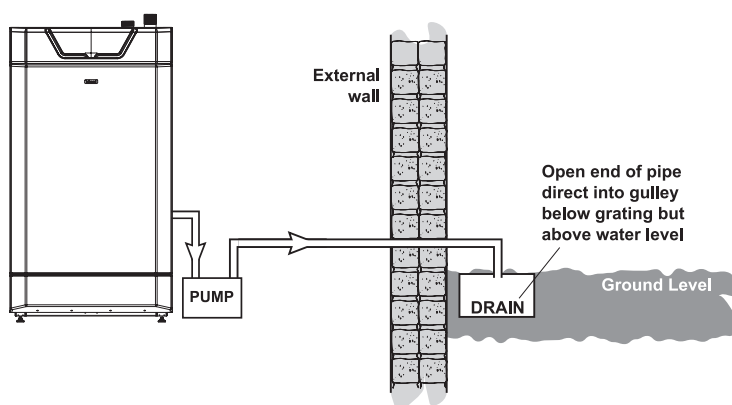

SEE INSTALLATION MANUAL FOR FULL INSTRUCTIONS AND SYSTEM OPTIONS





TRUSTED  
HEATING  
SOLUTIONS.

# HERE FOR YOU.

At Ideal, we are committed to delivering the highest levels of customer service. With over a century of experience in the heating industry, we know how important confidence and trust is to our customers.

You can be confident to know that you're partnering with a British manufacturer that's supported by a dedicated national service team, delivering help and advice to you and your customers throughout the year.

## NEED HELP?

GET IN TOUCH WITH US TODAY

### SALES

Tel: 0844 5436060  
Fax: 0844 5436181

### TECHNICAL

Tel: 01482 498376 Fax: 01482 498621  
[commercial.services@idealboilers.com](mailto:commercial.services@idealboilers.com)

## BOILER TRAINING

WE'VE GOT TRAINING COVERED

Our comprehensive one-day courses can be mixed and matched for individual installation and servicing companies. Each course uses a simple step-by-step approach with hands on training to ensure all aspects of commissioning, servicing, and fault finding can be dealt with quickly and efficiently.

**BOOK ONLINE AT:**

[idealcommercialboilers.com](http://idealcommercialboilers.com)



## NOTES.

---

---

---

---

---

---

---

---

---

---

---

---

---

---

---

---

---

---

---

---

---

---

---

---

# NOTES.

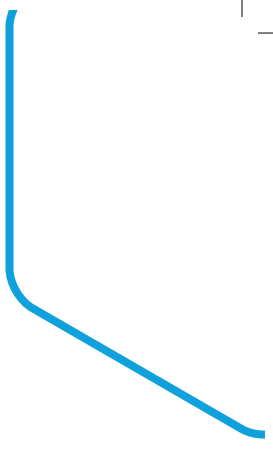

---

---

---

---

---

---

---

---

---

---

---

---

---

---

---

---

---

---

---

---

---

---

---





WE HAVE IT **COVERED.**

P.O. Box 103, National Avenue  
Kingston Upon Hull, HU5 4JN

**T:** 0844 5436060

**F:** 0844 5436181

[idealcommercialboilers.com](http://idealcommercialboilers.com)

 [@idealcommercial](https://twitter.com/idealcommercial)  [Ideal Boilers](https://www.linkedin.com/company/ideal-boilers)  [@idealcommercialboilers](https://www.facebook.com/idealcommercialboilers)



#### APPROVAL

These appliances are certified to G.A.D. 90/396 and B.E.D. 92/42 Safety and Performance Directives for gas boilers. Ideal Commercial Boilers pursues a policy of continuous improvement in design and performance of its products and reserves the right to vary specification without notice. Statutory rights of the consumer are not affected.

#### PLEASE NOTE:

The information in this brochure was correct at the time of going to print. Ideal Commercial Boilers reserve the right to make any modifications to product specifications or any other details, without prior notification. For further clarification, please enquire in writing to the head office address (address below).