

EVOMAX CONDENSING BOILER

PRODUCT & FLUE GUIDE



WE HAVE IT **COVERED.**

idealcommercialboilers.com

ideal
COMMERCIAL

Ideal Commercial Boilers is the UK's market leader of high efficiency commercial heating solutions.

Operating from its Hull manufacturing plant and offices since 1906, Ideal Commercial Boilers is one of the few true British manufacturers left in the heating industry.



BRING BOILERS TO LIFE

Your phone or tablet can let you appreciate our Evomax range in a new dimension.

The Ideal Commercial Eye app uses the latest technology to project 3D renders from the page of this brochure on to your device.

To see this for yourself, simply download the Ideal Commercial Eye app for free from your device's app store. Open the app and then place your device over the boiler image that has this icon next to it:



2	Introduction
4-13	Evomax 30 - 150kW
14-25	Evomax Cascade 30 - 600kW
26-37	Evomax Flue Options
38-39	Flue Types
40-46	Guide to Flue Installation & Regulation
47	Condensate Pumps
48-49	Ideal Training & Support

EVOMAX

30 - 150kW

5 YEAR
WARRANTY*



BRITISH
MANUFACTURING

*5 year warranty subject to Terms and Conditions. 5 years parts and labour warranty available subject to being commissioned by Ideal Boilers.



EVOMAX

30 - 150kW



Available in outputs of 30, 40, 60, 80, 100, 120 and 150kW, the Evomax is designed to ensure all installation requirements can be achieved. There is also an LPG Evomax range from 30 - 80 kW for off mains installations.



FEATURES & BENEFITS

- 5 year warranty*
- Robust & light aluminium silicon alloy heat exchanger
- Up to 110% part load efficiency
- High 5:1 turndown
- Compact - one width & height for easy siting
- Simple controls interface with large backlit display
- Comprehensive range of flue, fixing and control options
- Designed for easy installation, commissioning and servicing
- Proven reliability through design, component selection and proving
- NOx <40mg/kWh (Class 5) for all natural gas models for maximum BREEAM points



DIMENSIONS & CLEARANCES

BOILER	DIM A	DIM B	DIM C
30, 40, 60, 80	360	130	118
100, 120	520	226	118
150	610	233	120

All dimensions in mm

The following minimum clearances must be maintained for operation and servicing:



CLEARANCE BETWEEN MULTIPLE BOILER INSTALLATIONS: 25mm

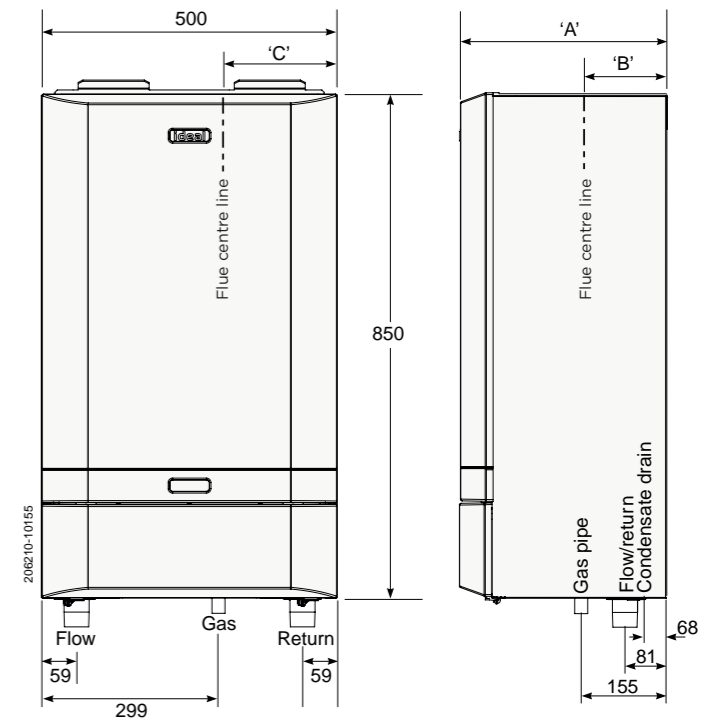

BOILER ASSEMBLY

INTERNAL VIEW (80kW MODEL SHOWN)

KEY

1. Auto Air Vent
2. Burner Fixings
3. Fan
4. Gas Valve
5. Venturi
6. Flow Thermistor
7. Ignitor Unit
8. Electrode Detection
9. Ignition Electrode
10. Fascia and Controls
11. Door Assembly
12. Water pressure sensor

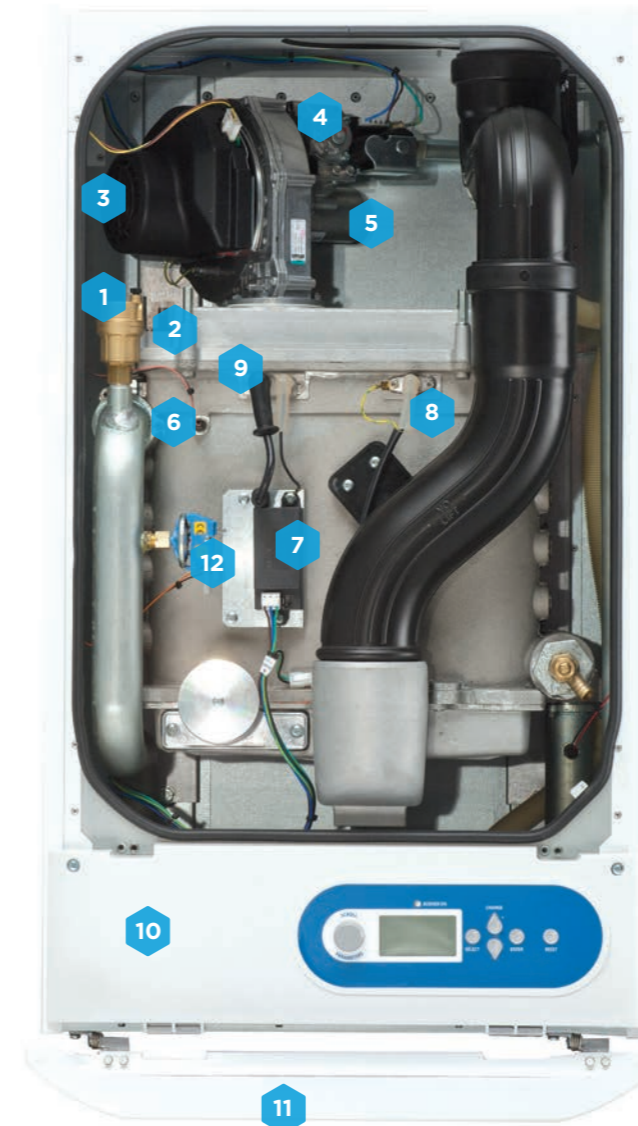

PERFORMANCE DATA

EVOMAX 30 - 150 KW

MODEL			30	30P	40	40P	60	60P	80	80P	100	120	150
Boiler Output (non-condensing) Mean 70°C	Max	kW	30	30	40	40	60	60	80	80	100	120	150
	Min	kW	6	6	8	8	12	15	16	20	20	24	30
Boiler Output (condensing) Mean 40°C	Max	kW	31.54	30.9	42.0	41.2	63.5	62.1	84.4	82.6	103.9	124.7	158.0
	Min	kW	6.5	6.4	8.5	8.3	12.7	15.5	17.2	21.2	21.6	26.0	32.5
Boiler Input Max Rate	Net	kW	30.4	30.4	40.5	40.5	60.8	60.7	82.0	81.9	102.4	122.9	153.7
	Gross	kW	33.7	33	44.9	44	67.4	66	90.9	88.9	113.6	136.4	170.5
Boiler Input Min Rate	Net	kW	6.1	6.1	8.1	8.1	12.2	15.2	16.4	20.5	20.5	24.6	30.7
	Gross	kW	6.7	6.6	9.0	8.8	13.5	16.5	18.2	22.2	22.7	27.3	34.1
Gas Rate	Max rate	m³/hr	3.2	1.26	4.3	1.69	6.4	2.53	8.7	3.41	10.8	13.0	16.2
Flue Gas Flow Rate	Max Rate	m³/hr	47.6	46.5	63.4	62.1	95.1	93.1	128.3	125.4	160.3	192.5	240.7
CO ₂ (±0.5%)	Max Rate	%	9.7	11.4	9.7	11.4	9.7	11.4	9.7	11.4	9.7	9.7	9.7
	Min Rate	%	8.7	10.2	8.7	10.2	8.7	10.5	8.7	10.5	8.7	8.7	8.7
NO _x with O ₂ = 0%	Weighted	mg/kWh	31.0	79	39.1	80	32.3	83.8	39.8	68	39.6	38.8	38.1
		ppm	17.6	45	22.2	45	18.3	47.5	22.9	38.5	22.5	22.0	21.6
Efficiency	Seasonal	%	96.7	97.2	96.2	96.7	96.4	96.9	97.2	97.7	96.7	96.6	96.7
	*SEDBUK 2009	%	89.6	90.6	89.3	90.3	89.4	90.5	n/a	n/a	n/a	n/a	n/a
Operating Temperature	Max	°C	82										

GENERAL DATA

EVOMAX 30 - 150 KW

MODEL		30/30P	40/40P	60/60P	80/80P	100	120	150
Gas Supply		2H - G20 - 20mbar / 3P - G31 - 37mbar						
Gas Supply Connection		G ¾						
Flow Connection		G1 ¼						
Return Connection		G1 ¼						
Max Pressure (sealed system)	Bar (psi)	4.0 (58)						
Maximum Static Head	m	40.7						
Electricity Supply		230V - 50Hz						
Fuse Rating	A	4.0						
Power Consumption	W	126	207	131	265	370	403	400
IP Rating		IP20						
Nominal Flue Size (concentric)	mm	80/125*				100/150		100/150**
Condensate Drain	mm	25						
Water Content	l	3.0		5.0		7.0		9.2
Dry Weight	Kg	49		60.30		75.70		89.75

*Optional kit available on 60/80 models for 100/150mm flue **For use with vertical flues only.

INCLUDED AS STANDARD

BOILER	EVOMAX
Remote indication (run & alarm)	✓
Hours run	✓
BMS (0-10v) operation	✓
Pump overrun	✓
Large backlit LCD controls, including 5 line plain text display	✓

OPTIONAL KITS

BOILER	EVOMAX
Modulating Sequencer kit	✓
Programmable Room Thermostat kit	✓
Outside sensor kit	✓
Tank Sensor kit	✓
Room sensor kit	✓
Safety Interlock kit	✓
Fittings kit	✓
Pump kit	✓
Multi boiler frame & header kits (includes low height options)	✓
Connection kit (includes isolation valve 1¼", non return valve, safety valve and drain cock)	✓

SUGGESTED ENGINEERING SPECIFICATION

OVERVIEW

The boilers must be fully automatically controlled, wall mounted, fanned, super-efficient condensing appliances utilising an aluminium silicon alloy heat exchanger and be suitable for connection to fully pumped open vented or sealed water systems.

CONTROLS

The condensing boilers must have connectivity for all common types of BMS integration including 0-10v, volt free and OpenTherm connections. Additional modules may be used for BACnet, LONWorks and MODBus gateways. Where no BMS is present a modulating sequencer must be available.

The boiler must be fully modulating with a 5:1 turndown ratio and include control features enabling set point adjustment, heating circuit control of one constant temperature and one DHW circuit or 2 constant temperature circuits, and safety lock out parameters including fault diagnosis for both boiler and external components such as sensors or pumps.

Boiler capabilities must include, with the use of external components, frost protection, weather or room compensation and system pump control.

FLUE

The condensing boilers must be suitable for use with a room sealed flue or open flue applications including C13, C33 and B23 classifications. The combined flue outlet and air inlet must be situated on the top of the boiler.

HYDRAULIC

The condensing boiler must be and be suitable for connection to fully pumped open vented or sealed water systems. All hydraulic connections including flow return and condensate drain must be located on the bottom of the boiler. Hydraulic connections must be uniform across the outputs available in the range to ensure ease of installation and maintenance in mixed output cascades. The boiler must have a maximum operating pressure of 6 bar and be suitable for heating and indirect hot water systems.

DIMENSIONS

The condensing boiler range must have a universal compact width and height across the range to ensure mixed output cascades maintain the same universal configuration. Maximum permitted wall area of 0.43m².

MOUNTING

The condensing boilers can be installed either on the wall or into a prefabricated floor mounted frame. Wall brackets must be located at the top of the boiler and visible from the front to aid installation.

EFFICIENCY

The condensing boilers are capable of high seasonal efficiencies with a minimum requirement of 96.2% and low NOx emissions no greater than 39.8mg/kWh for natural gas and 80mg/kWh for LPG.

30, 40 and 60kW models must have a Seasonal Space Heating Energy Efficiency of A.

APPROVALS

The boiler must be tested and certified to; EN 483, EN 677, PREN 15420, BSEN 15417, BSEN 656, BSEN 60335-2-102, BSEN 55014-1 and BSEN 55014-2 for use with Natural Gas & LPG. Boilers are certified to meet the requirements of the EC Gas Appliance Directive, Boiler Efficiency Directive, EMC and Low Voltage Directive.

The manufacturer must be ISO 9001 accredited.

SPECIFICATION

- The 30, 40, 60 and 80kW boiler will be capable of flow rates for common systems using either 11°C, 15°C or 20°C temperature differentials.
- The 100kW boiler will be capable of flow rates for common systems using either 15°C or 20°C temperature differentials.
- The 120 and 150kW boiler will be capable of flow rates for common systems using 20°C temperature differentials.

SOURCING

The condensing boiler must be manufactured or finally assembled in the United Kingdom.

CASCADE

The boiler must be configurable up to 6 boilers (max 600kW) in cascade using a prefabricated frame and header kit.

WARRANTY

The boiler must be available with a 5 year warranty.

SYSTEM TEMPERATURE

See pages 74-77 for further system requirements

DIFFERENTIALS

Flow rates for common systems using either 11°C, 15°C or 20°C temperature differentials are given in the table below.

BOILER	FLOW RATE (L/MIN)			HYDRAULIC RESISTANCE (MBAR)		
	11°C	15°C	20°C	11°C	15°C	20°C
Evomax 30 / 30P	39.1	28.7	21.5	425	225	127
Evomax 40 / 40P	52.1	38.2	28.7	875	405	225
Evomax 60 / 60P	78.2	57.3	43.0	435	180	83
Evomax 80 / 80P	104.2	76.4	57.3	750	420	180
Evomax 100	N/A	95.6	71.7	N/A	315	134
Evomax 120	N/A	N/A	86.0	N/A	N/A	218
Evomax 150	N/A	N/A	107.5	N/A	N/A	230

- 30-80 kW boilers must operate with temperature differentials from 11 to 20°C.
- 100 kW boilers must operate with temperature differentials not less than 15 to 20°C.
- 120-150 kW boilers must operate with temperature differentials not less than 20°C.

CONTROL KITS

PROGRAMMABLE ROOM THERMOSTAT KIT.

Timed control of central heating. Includes a built in electronic room sensor, optimised start and on/off controlled DHW.

MODULATING SEQUENCER KIT.

Controls up to 5 boilers for cascade operation. Air and Flow Header sensors are included.

OUTSIDE SENSOR KIT.

Provides weather compensation directly or with Programmable Room Thermostat kit.

TANK SENSOR KIT.

Provides DHW temperature control. Also for use with Sequencer kit.

ROOM SENSOR KIT.

Used with Modulating Sequencer kit for CH control.

SAFETY INTERLOCK KIT.

Provides boiler shut down via an external signal.

FLUE SYSTEMS

A comprehensive range of flue kits are available from Ideal Commercial Boilers including horizontal and vertical concentric and open flue options.

For horizontal flues: this is the distance from the flue outlet centre line on the boiler to the outside wall. Horizontal flue termination is not available for Evomax 150.

For vertical flue: this is the distance from the top of the boiler case to the aperture in the weather collar. If elbows are to be used, then the equivalent length of that fitting must be subtracted from the maximum flue extensions allowed for that flue option.

Note: Horizontal terminal resistance includes 1 x 90° elbow.

When installing Evomax boilers with concentric flue (horizontally or vertically) the Ideal Commercial flue system must be used.

The resistance of flue components, together with the maximum flue resistance each boiler can work against, may be used to calculate the total flue resistance of the system, and to determine if they are acceptable to run on the boiler.

Multiple boilers may be installed with a common flue header.

The flue system should be designed and supplied by a specialist flue company. BS 6644 and IGEN UP/10 provide guidance on design and the drainage of condensate from flue stack and headers. Condensate from a flue stack and header must be collected and drained before entering the boiler.

For Ventilation requirements please refer to the installation manual.

SYSTEM LAYOUT

TYPICAL SYSTEM BOILER LAYOUT

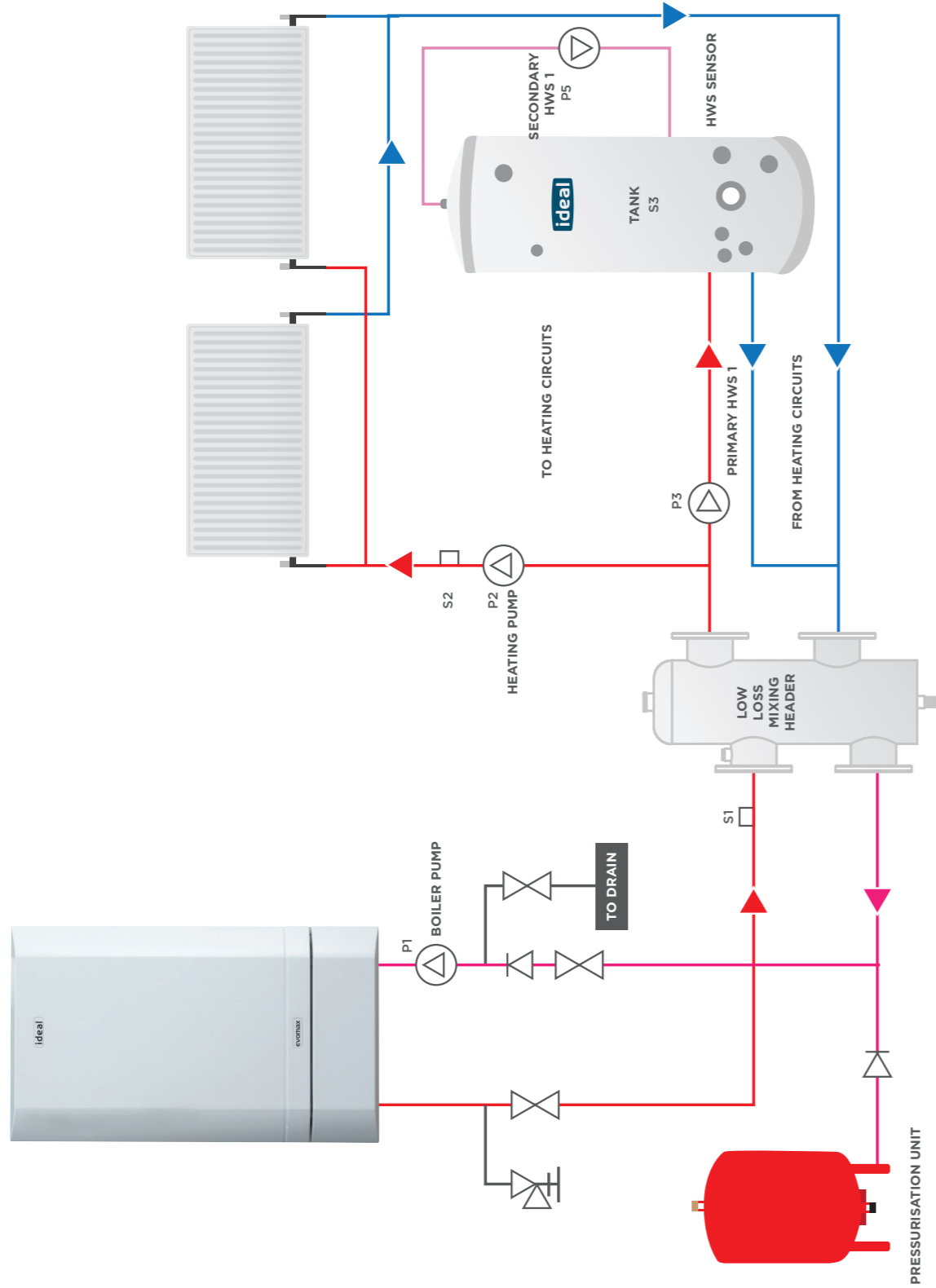



EVOMAX CASCADE

30 - 600kW



BRITISH
MANUFACTURING



WALL
HUNG

EVOMAX CASCADE

FRAME & HEADER KITS



BOILER FRAME AND HEADER KITS

The Frame and Header Kits are suitable for modular (cascade) boiler installations, and are available up to a maximum output of 600 kW, in both in-line and back-to-back arrangements.

IN-LINE KITS

Kits include flow & return headers with mixing header and gas header, all with fixing brackets. For easy connection flexible stainless steel pipe and connections are supplied together with pressure relief valves, boiler shut off valves and drain cock.

Appropriately sized ErP modulating shunt pumps are also included. Flow, return and low loss headers together with the flexible boiler connections are all pre insulated. Separate single boiler frame kits are available for use with in-line kits if required.

BACK-TO-BACK KITS

Kits include all the in-line contents plus the required special frame kits for such compact installations. Both types of kit are available for the following number of boilers and sizes. Mixing header kits and modulating pump kits are also available separately.



AVAILABLE OPTIONS

	MODELS	SIZE
2 boilers	30-100	DN80
2 boilers	120-150	DN80
3 boilers	30-100	DN80
3 boilers	120-150	DN100
4 boilers	30-100	DN100
4 boilers	120-150	DN100
5 boilers	30-100	DN100
5 boilers	120	DN100
6 boilers	30-100	DN100

In-line kits do not include the support frame as the boilers can be wall mounted, but a frame kit is available if the wall is unsuitable to facilitate boiler mounting.

For full details of all configurations & specifications, please refer to the installation manual.

Please note, the Evomax boilers are to be ordered separately.

FRAME & HEADER KITS

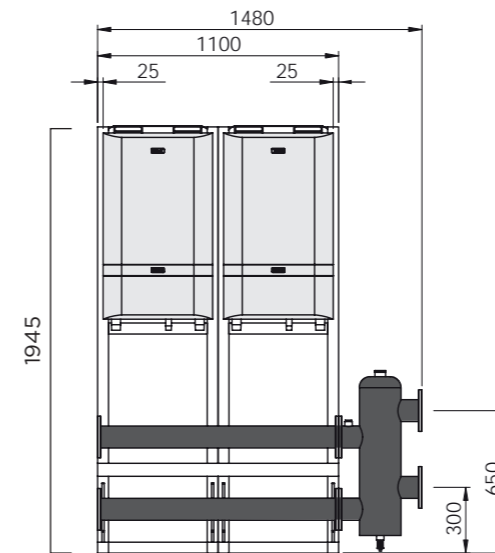

2 X EVOMAX 30 - 150 KW

HEADER KITS	RATING	HEIGHT (mm)	LENGTH (mm)	DEPTH (mm)	DN FLANGE SIZE	CONCENTRIC FLUE
UIN209799	30-80kW	1945	1100	552	DN80	80/125
	100kW	1945	1100	552	DN80	100/150
UIN209798	120-150kW	1945	1100	552	DN80	100/150

Measurements are without boilers attached. 100-150kW boilers are deeper than Frame and Header Kit.

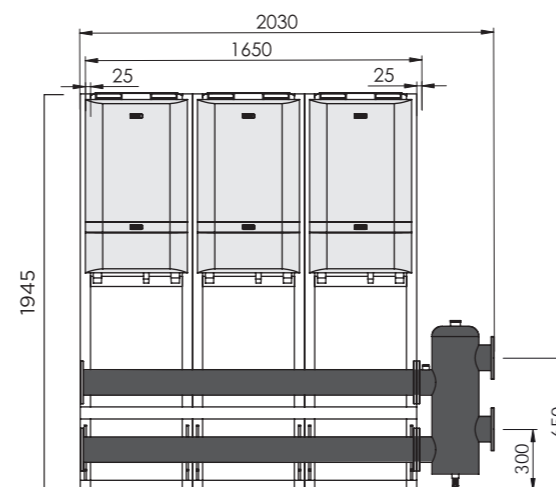

3 X EVOMAX 30 - 150 KW

HEADER KITS	RATING	HEIGHT (mm)	LENGTH (mm)	DEPTH (mm)	DN FLANGE SIZE	CONCENTRIC FLUE
UIN209801	30-80kW	1945	1650	552	DN80	80/125
	100kW	1945	1650	552	DN80	100/150
UIN209800	120-150kW	1945	1650	552	DN100	100/150

Measurements are without boilers attached. 100-150kW boilers are deeper than Frame and Header Kit.

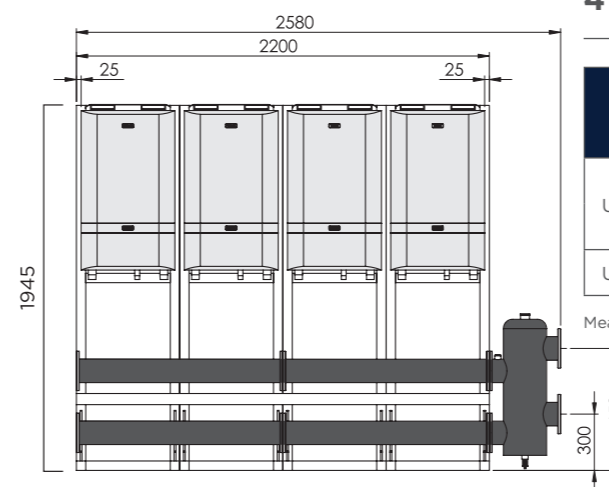

4 X EVOMAX 30 - 150 KW

HEADER KITS	RATING	HEIGHT (mm)	LENGTH (mm)	DEPTH (mm)	DN FLANGE SIZE	CONCENTRIC FLUE
UIN209803	30-80kW	1945	2200	552	DN100	80/125
	100kW	1945	2200	552	DN100	100/150
UIN209802	120-150kW	1945	2200	552	DN100	100/150

Measurements are without boilers attached. 100-150kW boilers are deeper than Frame and Header Kit.

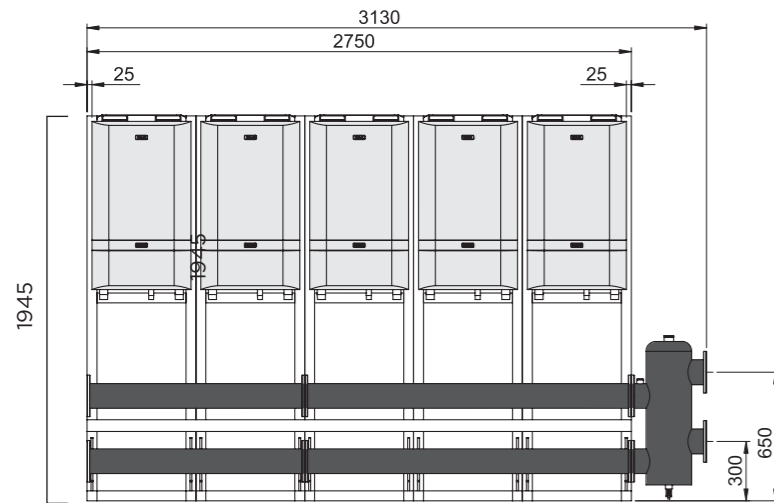

5 X EVOMAX 30 - 120 KW

HEADER KITS	RATING	HEIGHT (mm)	LENGTH (mm)	DEPTH (mm)	DN FLANGE SIZE	CONCENTRIC FLUE
UIN209805	30-80kW	1945	2750	552	DN100	80/125
	100kW	1945	2750	552	DN100	100/150
UIN209804	120kW	1945	2750	552	DN100	100/150

Measurements are without boilers attached. 100-120kW boilers are deeper than Frame and Header Kit.

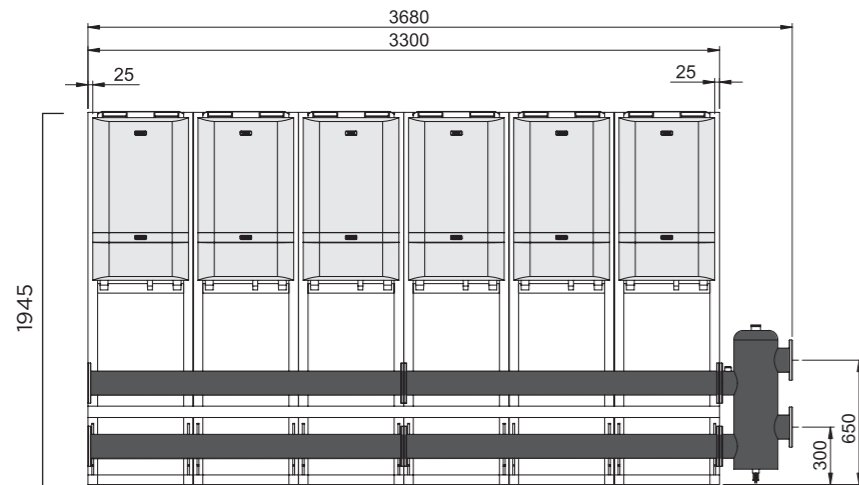

6 X EVOMAX 30 - 100 KW

HEADER KITS	RATING	HEIGHT (mm)	LENGTH (mm)	DEPTH (mm)	DN FLANGE SIZE	CONCENTRIC FLUE
UIN209806	30-80kW	1945	3300	552	DN100	80/125
	100kW	1945	3300	552	DN100	100/150

Measurements are without boilers attached. 100kW boilers are deeper than Frame and Header Kit.

FRAME & HEADER KITS

SYSTEM DESIGN OPTIONS

TOTAL OUTPUT REQUIRED KW	NO. OF BOILERS	SIDE BY SIDE OPTION - BOILER MODELS	SIDE BY SIDE FOOTPRINT SIZE W X D (MM)	HEADER KIT PRODUCT NO. SIDE BY SIDE	BOILER MODELS	BACK TO BACK FOOTPRINT SIZE W X D (MM)	FRAME/HEADER PRODUCT NO. BACK TO BACK
60	2	30	1480 x 552	209799	30	930x950	209901
70	2	30 + 40	1480 x 552	209799	30 + 40	930x950	209901
80	2	40	1480 x 552	209799	40	930x950	209901
90	2	30 + 60	1480 x 552	209799	30 + 60	930x950	209901
100	2	40 + 60	1480 x 552	209799	40 + 60	930x950	209901
110	2	30 + 80	1480 x 552	209799	30 + 80	930x950	209901
120	2	60	1480 x 552	209799	60	930x950	209901
130	3	30, 40 + 60	2030 x 552	209801	30, 40 + 60	480x950	209903
140	2	60 + 80	1480 x 552	209799	60 + 80	930x950	209901
150	3	30, 40 + 80	2030 x 552	209801	30, 40 + 80	480x950	209903
160	2	80	1480 x 552	209799	80	930x950	209901
170	3	30, 60 + 80	2030 x 552	209801	30, 60 + 80	480x950	209903
180	2	80 + 100	1480 x 573	209799	80 + 100	930x1096	209901
190	3	30, 60 + 100	2030 x 573	209801	30, 60 + 100	480x1096	209903
200	2	100	1480 x 573	209799	100	930x1096	209901
210	4	30, 40, 60 + 80	2580 x 552	209803	30, 40, 60 + 80	1480x950	209905
220	3	2 x 60 + 100	2030 x 573	209801	2 x 60 + 100	1480x1096	209903
230	4	30, 40, 60 + 80	2580 x 573	209803	30, 40, 60 + 100	1480x1096	209905
240	2	120	1480 x 663	209798	120	930x1276	209900
250	4	30, 60, 2 x 80	2580 x 552	209803	30, 60, 2 x 80	1480x950	209905
260	3	60, 2 x 100	2030 x 573	209801	60, 2 x 100	1480x1096	209903
270	2	120 + 150	1480 x 663	209798	120 + 150	930x1276	209900
280	3	80, 2 x 100	2030 x 573	209801	80, 2 x 100	1480x1096	209903
290	4	30, 60, 2 x 100	2580 x 573	209803	30, 60, 2 x 100	1480x1096	209905
300	2	150	1480 x 663	209798	150	930x1276	209900
310	4	30, 80, 2 x 100	2580 x 573	209803	30, 80, 2 x 100	1480x1096	209905
320	4	40, 80, 2 x 100	2580 x 573	209803	40, 80, 2 x 100	1480x1096	209905
330	4	30, 3 x 100	2580 x 573	209803	30, 3 x 100	1480x1096	209905
340	4	60, 80, 2 x 100	2580 x 573	209803	60, 80, 2 x 100	1480x1096	209905
350	5	30, 40, 80, 2 x 100	3130 x 573	209805	30, 40, 80, 2 x 100	2030x1096	209907

SYSTEM DESIGN OPTIONS - CONTINUED

TOTAL OUTPUT REQUIRED KW	NO. OF BOILERS	SIDE BY SIDE OPTION - BOILER MODELS	SIDE BY SIDE FOOTPRINT SIZE W X D (MM)	HEADER KIT PRODUCT NO. SIDE BY SIDE	BOILER MODELS	BACK TO BACK FOOTPRINT SIZE W X D (MM)	FRAME/HEADER PRODUCT NO. BACK TO BACK
360	3	120	2030x663	209800	120	1480x1276	209902
370	5	30, 40, 3 x 100	3130x573	209805	30, 40, 3 x 100	2030x1096	209907
380	4	80, 3 x 100	2030x573	209801	80, 2 x 100	1480x1096	209903
390	3	2 x 120 + 150	2030x663	209800	2 x 120 + 150	1480x1276	209902
400	4	100	2580x573	209803	100	1480x1096	209905
410*	5	30, 80, 3 x 100	3130x573	209805	30, 80, 3 x 100	2030x1096	209907
420	3	120, 2 x 150	2030x663	209800	120, 2 x 150	1480x1276	209902
430*	5	30, 4 x 100	2580x573	209805	30, 4 x 100	1480x1096	209905
440*	5	40, 4 x 100	2580x573	209805	40, 4 x 100	1480x1096	209905
450	3	150	2030x663	209800	150	1480x1276	209902
460*	5	60, 4 x 100	3130x573	209805	60, 4 x 100	2030x1096	209907
470*	6	30, 40, 3 x 100	3680x573	209806	30, 40, 3 x 100	2030x1096	209908
480	4	120	2580x663	209802	120	480x1276	209904
490*	6	30, 60, 4 x 100	3680x663	209806	30, 60, 4 x 100	2030x1096	209908
500	5	100	3130x573	209805	100	2030x1096	209908
510	4	3 x 120 + 150	2580x663	209802	3 x 120 + 150	1480x1276	209904
520*	6	40, 80, 4 x 100	3680x573	209806	40, 80, 4 x 100	2030x1096	209908
530*	6	30, 5 x 100	3680x573	209806	30, 5 x 100	2030x1096	209908
540	4	2 x 120, 2 x 150	2580x663	209802	2 x 120, 2 x 150	1480x1276	209904
550		N/A	N/A	N/A	N/A	N/A	N/A
560*	6	60, 5 x 100	3680x573	209806	60, 5 x 100	2030x1096	209908
570	4	120, 3 x 150	2580x663	209802	120, 3 x 150	1480x1276	209904
580*	6	80, 5 x 100	3680x573	209806	80, 5 x 100	2030x1096	209908
590		N/A	N/A	N/A	N/A	N/A	N/A
600	4	150	2580x663	209802	150	1480x1276	209904

* Not suitable configuration for multiline flue

MULTILINE FLUE CASCADE

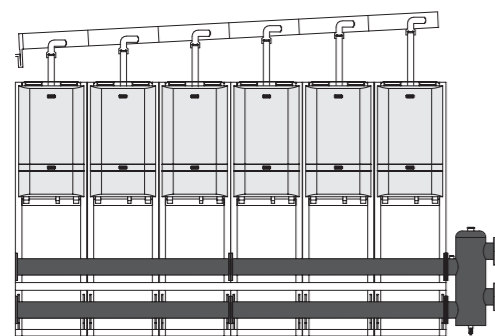

FEATURES AND BENEFITS

- Allows Evomax boilers installed as open flue to be connected via a common flue header, creating a single line connection point
- Basic kit includes, appliance connection, non-return flue damper, condensate tee and trap and all clips to secure the flue
- Extension pack includes appliance connection, non-return flue damper, and all clips to secure the flue
- Available for both 80/125 & 100/150 flue adaptor applications
- For installations up to 600kW as both a starter kit and extension pack

OPTION	GAS TYPE	EVOMAX MODELS	MAX NUMBER OF BOILERS	MAX SYSTEM CAPACITY
1	Natural gas	Combinations of 100, 120, 150	6	600kW
2		Combinations that include a 30, 40, 60 or 80	6	400kW
3	Propane	Combinations of 30P, 40P, 60P, 80P	6	400kW

Flue height = 570mm from the top of the first boiler in the system. Increase the height 29mm for each adjacent boiler.

EVOMAX CASCADE

LOW HEIGHT FRAME & HEADER KITS

BOILER FRAME AND HEADER KITS

The Low Height Frame and Header Kits make installation much simpler in circumstances of reduced headroom, offering an option of replacing a floor standing atmospheric boiler with a high efficiency model.

Three options are available allowing for outputs from 30 kW to 450 kW.

FEATURES & BENEFITS

- Frame and Header Kits fit easily through standard doorways
- Lift weights are as low as possible
- The Low Height Frame and Header Kit is supplied on one palette shrink wrapped together with all ancillary fittings needed for assembly
- All pipe work connections are supplied with either the boiler, header kit or are pre assembled to the header kit
- Pre assembled to header; the boiler the flow and return flexible connections, which reduce installation time
- Delivered with header kit; connection pipe assembly, non return valves & pipe work connector, all isolation valves, pressure relief valve, drain cock and associated fittings
- The Low Height Frame and Header Kit can be installed with either an Ideal Commercial Sequencer offering direct modulation of the system, reducing running costs, or a proprietary option
- The extremely compact dimensions allow for replacement of existing standard efficiency floor standing boilers, using a single wall mounted condensing boiler up to 150 kW allowing sufficient space to install flue system, pump and pipe headers
- High quality and well-finished components
- Supplied with frames and low energy modulating pumps (ErP approved)



FLUEING OPTIONS

NOX CLASS 5

BIM

AVAILABLE OPTIONS

	MODELS	SIZE	LOW LOSS HEADER KIT
1 Boiler	30-150	DN50 (2" BSP)	✓
2 Boiler	60-300	DN65	✓
3 Boiler	90-450	DN80	✓

LOW HEIGHT FRAME & HEADER KITS

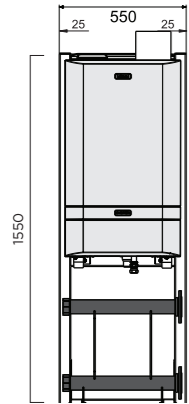

1 X EVOMAX 30 - 150 KW

HEADER KITS	HEIGHT (mm)	LENGTH (mm)	DEPTH (mm)	DN FLANGE SIZE	CONCENTRIC FLUE
30-80kW	1550	550	642	DN50 (2" BSP)	80/125
100-120kW	1550	550	642		100/150
150kW	1550	550	642		100/150

Measurements are without boilers attached. 150kW boilers are deeper than Low Height Frame and Header

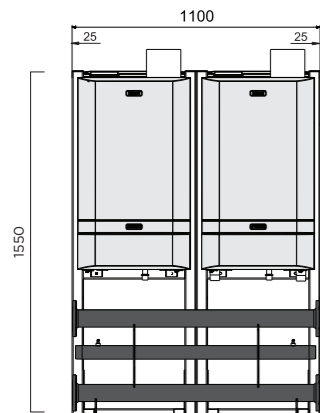

2 X EVOMAX 30 - 150 KW

HEADER KITS	HEIGHT (mm)	LENGTH (mm)	DEPTH (mm)	DN FLANGE SIZE	CONCENTRIC FLUE
30-80kW	1550	1100	642	DN65	80/125
100-120kW	1550	1100	642		100/150
150kW	1550	1100	642		100/150

Measurements are without boilers attached. 150kW boilers are deeper than Low Height Frame and Header

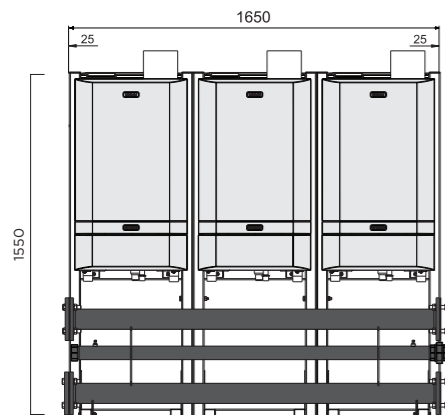

3 X EVOMAX 30 - 150 KW

HEADER KITS	HEIGHT (mm)	LENGTH (mm)	DEPTH (mm)	DN FLANGE SIZE	CONCENTRIC FLUE
30-80kW	1550	1650	642	DN80	80/125
100-120kW	1550	1650	642		100/150
150kW	1550	1650	642		100/150

Measurements are without boilers attached. 150kW boilers are deeper than Low Height Frame and Header

LOW HEIGHT FRAME & HEADER KITS

SYSTEM DESIGN OPTIONS

TOTAL OUTPUT REQUIRED KW	NO. OF BOILERS	HEADER	SIDE BY SIDE FOOTPRINT SIZE W X D (MM)	OPTIONAL LOW LOSS HEADER	BOILER MODELS	FRAME/HEADER PRODUCT NO.
30	1	DN50	550 x 642	209394	1	210012
40	1	DN50	550 x 642	209394	1	210012
60	1	DN50	550 x 642	209394	1	210012
80	1	DN50	550 x 642	209394	1	210012
100	1	DN50	550 x 642	209394	1	210012
120	1	DN50	550 x 642	209394	1	210012
150	1	DN50	550 x 666	209394	1	210012
60	2	DN65	1100 x 642	209395	2 x 30	210029
70	2	DN65	1100 x 642	209395	1 x 30 + 1 x 40	210029
80	2	DN65	1100 x 642	209395	2 x 40	210029
90	2	DN65	1100 x 642	209395	1 x 60 + 1 x 30	210029
100	2	DN65	1100 x 642	209395	1 x 60 + 1 x 40	210029
110	2	DN65	1100 x 642	209395	1 x 80 + 1 x 30	210029
120	2	DN65	1100 x 642	209395	2 x 60	210029
130	2	DN65	1100 x 642	209395	1 x 100 + 1 x 30	210029
140	2	DN65	1100 x 642	209395	1 x 80 + 1 x 60	210029
140	2	DN65	1100 x 642	209395	1 x 100 + 1 x 40	210029
150	2	DN65	1100 x 642	209395	1 x 120 + 1 x 30	210029
160	2	DN65	1100 x 642	209395	2 x 80	210029
160	2	DN65	1100 x 642	209395	1 x 100 + 1 x 60	210029
180	2	DN65	1100 x 642	209395	1 x 100 + 1 x 80	210029
180	2	DN65	1100 x 642	209395	1 x 120 + 1 x 60	210029
180	2	DN65	1100 x 666	209395	1 x 150 + 1 x 30	210029
190	2	DN65	1100 x 666	209395	1 x 150 + 1 x 40	210029
200	2	DN65	1100 x 642	209395	2 x 100	210029
200	2	DN65	1100 x 642	209395	1 x 120 + 1 x 80	210029
210	2	DN65	1100 x 666	209395	1 x 150 + 1 x 60	210029
220	2	DN65	1100 x 642	209395	1 x 120 + 1 x 100	210029
230	2	DN65	1100 x 666	209395	1 x 150 + 1 x 80	210029
240	2	DN65	1100 x 642	209395	2 x 120	210029
250	2	DN65	1100 x 666	209395	1 x 150 + 1 x 100	210029
270	2	DN65	1100 x 666	209395	1 x 150 + 1 x 120	210029
300	2	DN65	1100 x 666	209395	2 x 150	210029
90	3	DN80	1650 x 642	252437	3 x 30	210020
100	3	DN80	1650 x 642	252437	1 x 40 + 2 x 30	210020
110	3	DN80	1650 x 642	252437	2 x 40 + 1 x 30	210020
120	3	DN80	1650 x 642	252437	3 x 40	210020
120	3	DN80	1650 x 642	252437	1 x 60 + 2 x 30	210020
130	3	DN80	1650 x 642	252437	1 x 60 + 1 x 40 + 1 x 30	210020
140	3	DN80	1650 x 642	252437	1 x 60 + 2 x 40	210020
150	3	DN80	1650 x 642	252437	2 x 60 + 1 x 30	210020
160	3	DN80	1650 x 642	252437	1 x 80 + 2 x 40	210020
170	3	DN80	1650 x 642	252437	1 x 80 + 1 x 60 + 1 x 30	210020
180	3	DN80	1650 x 642	252437	3 x 60	210020
180	3	DN80	1650 x 642	252437	1 x 100 + 2 x 40	210020
190	3	DN80	1650 x 642	252437	2 x 80 + 1 x 30	210020
200	3	DN80	1650 x 642	252437	2 x 80 + 1 x 40	210020
220	3	DN80	1650 x 642	252437	2 x 80 + 1 x 60	210020

SYSTEM DESIGN OPTIONS - CONTINUED

TOTAL OUTPUT REQUIRED KW	NO. OF BOILERS	HEADER	SIDE BY SIDE FOOTPRINT SIZE W X D (MM)	OPTIONAL LOW LOSS HEADER	BOILER MODELS	FRAME/HEADER PRODUCT NO.
230	3	DN80	1650 x 642	252437	2 x 100 + 1 x 30	210020
240	3	DN80	1650 x 642	252437	3 x 80	210020
240	3	DN80	1650 x 642	252437	2 x 100 + 1 x 40	210020
250	3	DN80	1650 x 642	252437	1 x 120 + 1 x 100 + 1 x 30	210020
260	3	DN80	1650 x 642	252437	1 x 120 + 1 x 100 + 1 x 40	210020
270	3	DN80	1650 x 642	252437	2 x 120 + 1 x 30	210020
280	3	DN80	1650 x 666	252437	1 x 150 + 1 x 100 + 1 x 30	210020
290	3	DN80	1650 x 666	252437	1 x 150 + 1 x 100 + 1 x 40	210020
300	3	DN80	1650 x 642	252437	3 x 100	210020
320	3	DN80	1650 x 642	252437	2 x 100 + 1 x 120	210020
320	3	DN80	1650 x 642	252437	2 x 120 + 1 x 80	210020
340	3	DN80	1650 x 642	252437	2 x 120 + 1 x 100	210020
350	3	DN80	1650 x 666	252437	1 x 150 + 2 x 100	210020
360	3	DN80	1650 x 642	252437	3 x 120	210020
370	3	DN80	1650 x 666	252437	1 x 150 + 1 x 120 + 1 x 100	210020
380	3	DN80	1650 x 666	252437	2 x 150 + 1 x 80	210020
390	3	DN80	1650 x 666	252437	1 x 150 + 2 x 120	210020
400	3	DN80	1650 x 666	252437	2 x 150 + 1 x 100	210020
420	3	DN80	1650 x 666	252437	2 x 150 + 1 x 120	210020
450	3	DN80	1650 x 666	252437	3 x 150	210020

SYSTEM LAYOUT

TYPICAL SYSTEM BOILER LAYOUT

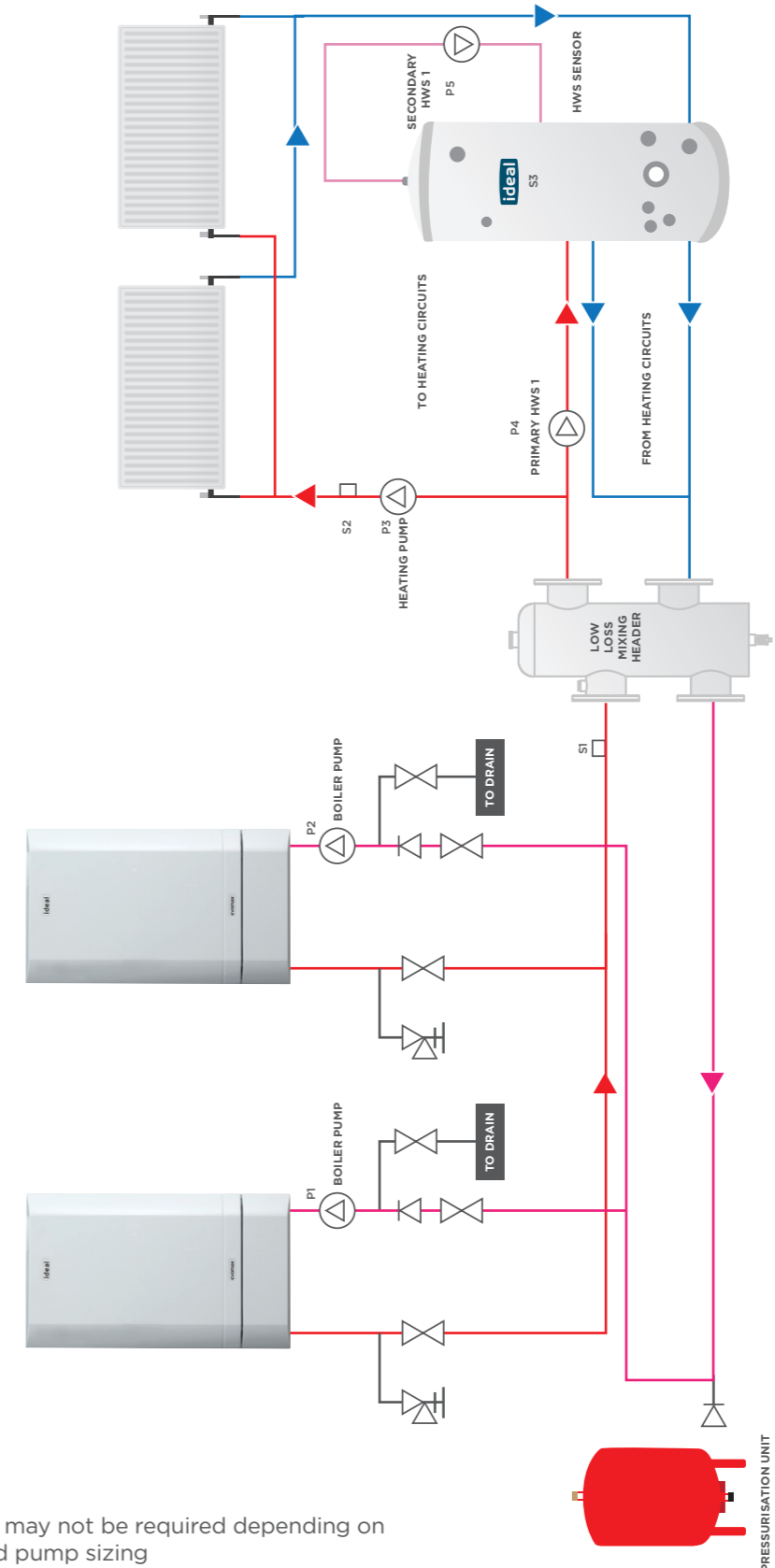

* Low loss header may not be required depending on system design and pump sizing

EVOMAX FLUE OPTIONS

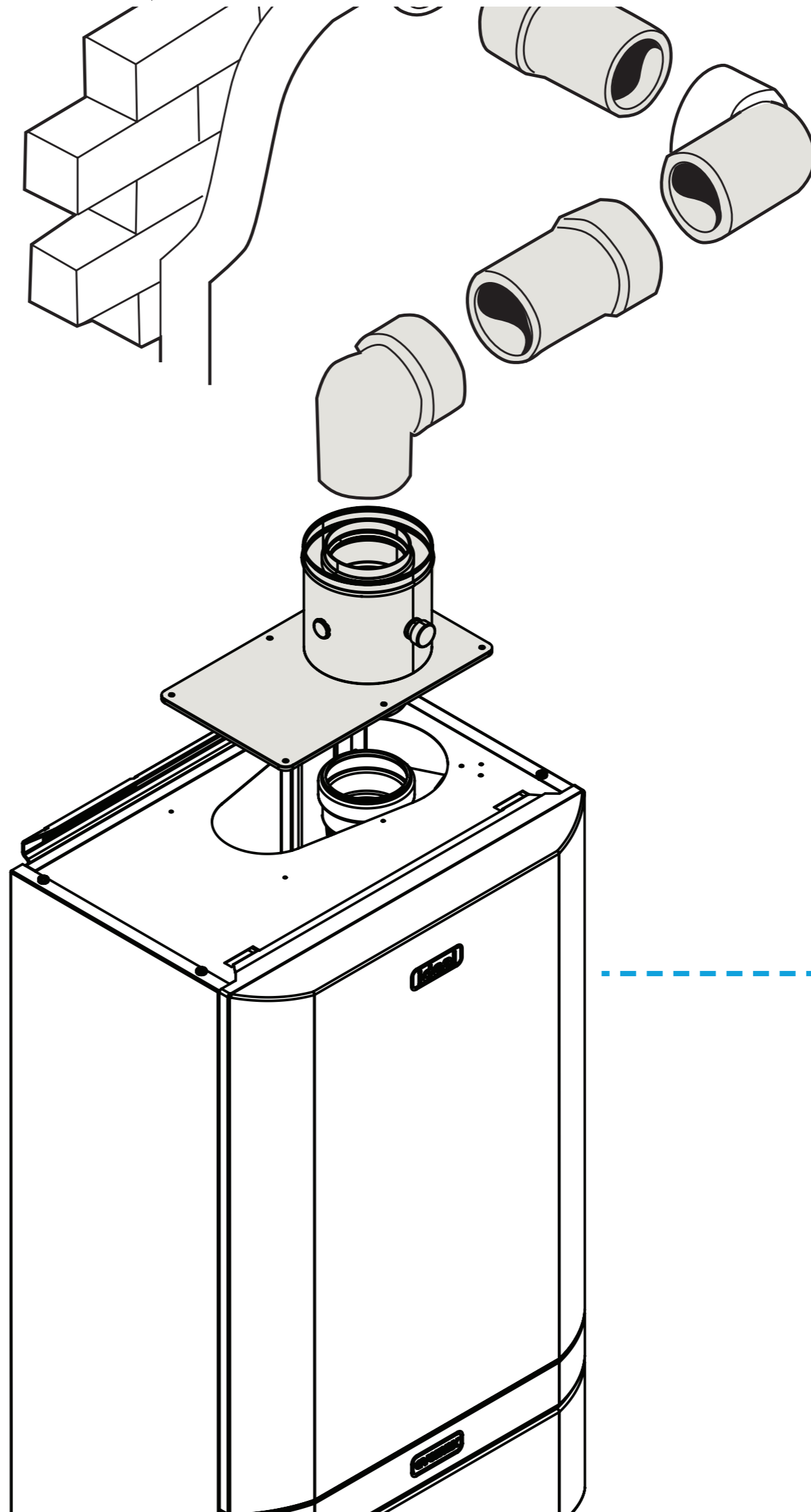

CONCENTRIC FLUE OPTIONS (C TYPE)

HORIZONTAL WALL FLUE KIT

EVOMAX HORIZONTAL CONCENTRIC FLUE APPLICATION - MAXIMUM LENGTHS AND PRESSURE DIFFERENTIALS

Model	30/30P	40/40P	60/60P	80/80P	100	120
Max flue length (m)	42	42	7.5	12	14.3	17.6
Flue Size	80/125			100/150		
Wall flue kit No	213267			213269		

- CONTENTS**
- Boiler adapter + screws (x6)
 - 90° elbow
 - Terminal
 - Locking collars (x2)
 - Wall plates (x2)

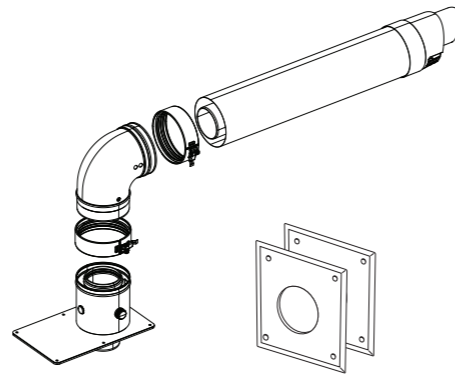

EVOMAX 60 & 80 HORIZONTAL CONCENTRIC FLUES OF LONGER LENGTHS (LARGER FLUE DIAMETER)

Model	60/60P	80/80P
Max flue length (m)	30	35
Flue Size	100/150	
Wall flue kit No	213268	

- CONTENTS**
- Boiler adapter + screws (x6)
 - Increaser
 - 90° elbow
 - Terminal
 - Locking collars (x2)
 - Wall plates (x2)

To comply with CE certification, Evomax boilers must be fitted with Ideal concentric flues (when using concentric flue type).

VERTICAL ROOF FLUE KIT

EVOMAX VERTICAL CONCENTRIC FLUE APPLICATION - MAXIMUM LENGTHS AND PRESSURE DIFFERENTIALS

Model	30/30P	40/40P	60/60P	80/80P	100	120	150
Max flue length (m)	42	42	7.5	12	14.3	17.6	7.5
Flue Size	80/125			100/150			
Wall flue kit No	213264			213266			

- CONTENTS**
- Boiler adapter + screws (x6)
 - Terminal
 - Locking Collar
 - Finishing plates (x2)
 - Bracket

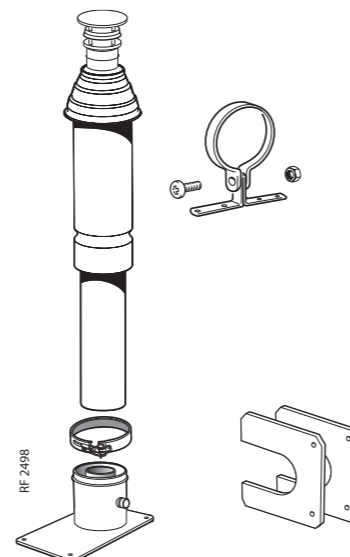

EVOMAX 60 & 80 VERTICAL CONCENTRIC FLUES OF LONGER LENGTH

Model	60/60P	80/80P
Max flue length (m)	30	35
Flue Size	100/150	
Wall flue kit No	213265	

- CONTENTS**
- Boiler adapter + screws (x6)
 - Increaser
 - Terminal
 - Locking Collars (x2)
 - Finishing plates (x2)
 - Bracket

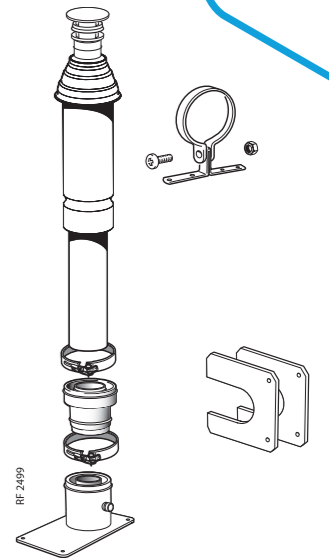

OPEN FLUE OPTIONS (B TYPE)

EVOMAX VERTICAL CONCENTRIC FLUE APPLICATION - MAXIMUM LENGTHS AND PRESSURE DIFFERENTIALS

Model	30/30P	40/40P	60/60P	80/80P	100	120	150
Max flue length (m)	65	70	25	22	20	49	32
Max flue press diff (Pa)	140	225	150	312	220	365	430
Flue Size	80/125			100/150			
Wall flue kit No	158662 + 158771 + 158769			158663 + 158772 + 158770			

CONTENTS

- | | | |
|--------------------------------|-----------------|-------------------------|
| 158662 / 158663 | 158769 / 158770 | 158771 / 158772 |
| • Boiler adapter + screws (x6) | • Terminal | • Extension tube (x2)** |
| • Air inlet grille* | | |

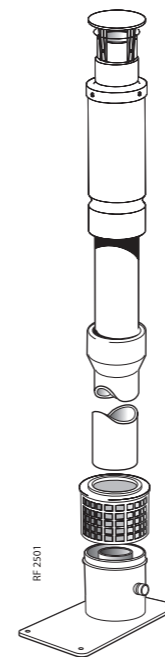

* The boiler / adapter & air inlet grille must be fitted to all installations.
 ** At least 1 off extension tube MUST be used in the installation. This may be suitably cut to length if required.

To comply with CE certification, Evomax boilers must be fitted with an Ideal boiler adapter.

- B type flues must use the inlet grille.
- C type flues must use a complete Evomax flue.

FLUE KIT ACCESSORIES

ACCESSORY	FLUE TYPE	PART NO.				
		80/125	100/150	80	100	
1	90° elbow (concentric)	C	213259	213263	N/A	N/A
2	45° elbow (concentric)	C	213260	213258	N/A	N/A
3	90° elbow	B	N/A	N/A	158773	158774
4	45° elbow (pair)	B	N/A	N/A	158775	158776
5	Flat Weather Collar	B/C	152611	152612	152259	152259
6	Pitched Weather Collar	B/C	152609	152610	158779	158779
7	1m Extension (concentric)	C	213261	213262	N/A	N/A
8	1m Extension (pair)	B	N/A	N/A	158771	158772
9	Increaser 80-100	B	N/A	N/A	152404	N/A
Wall bracket	B/C	202242	202243	N/A	N/A	N/A

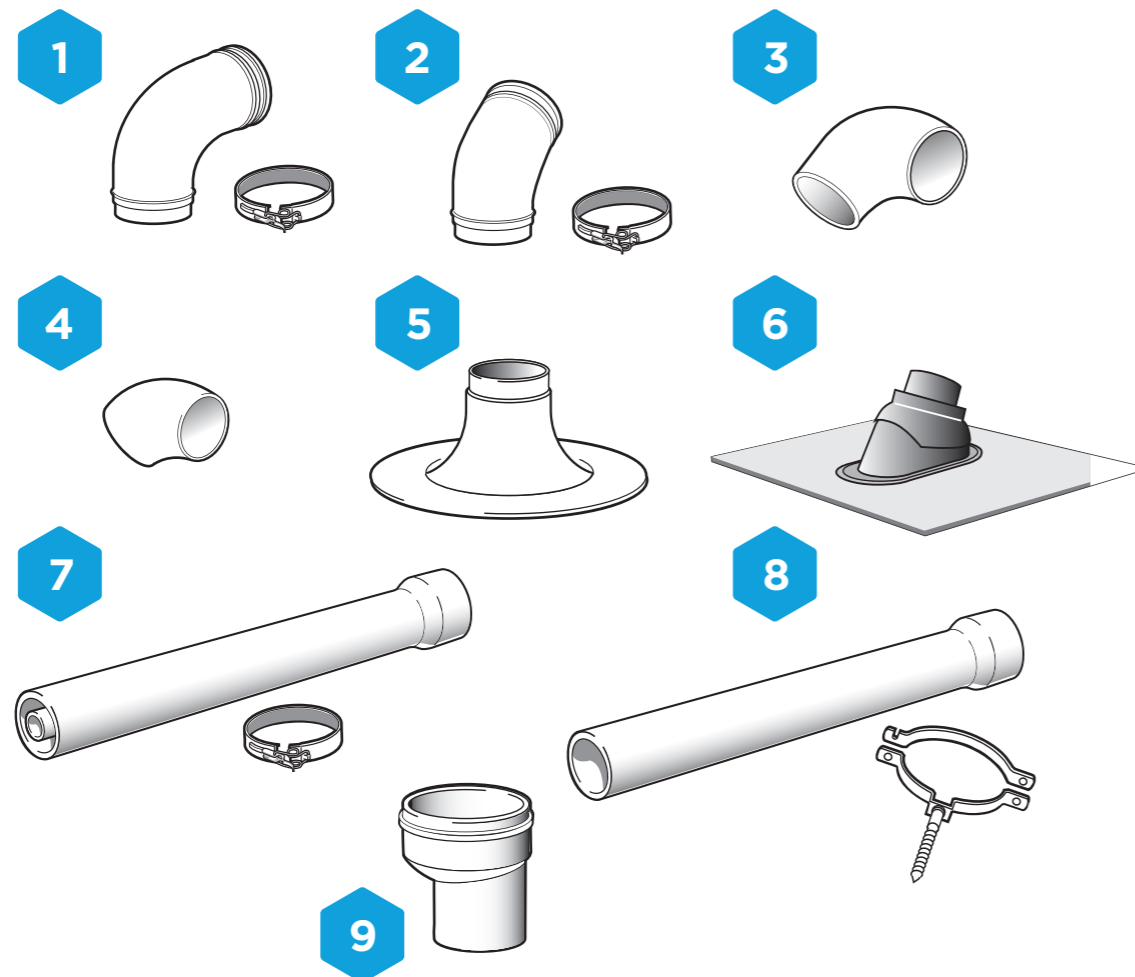

FLUE RESISTANCES

FLUE SYSTEMS

For concentric flue systems with elbows fitted, use the table to correct the maximum flue extension capability. Alternatively use the table to design the flue system, deducting the individual resistance of components from the maximum pressure drop allowed in the flue for that boiler. The maximum pressure drop allowed in the flue is given below.

PERMISSIBLE FLUE LENGTH

The maximum permissible flue lengths for each model are shown in Table 1 below, these lengths are inclusive of the terminal resistance. The value shown is the maximum available length for extension. The equivalent length of elbows is shown in Table 2.

TABLE 1

Flue Size	MAX PERMISSIBLE EQUIVALENT FLUE LENGTH (INC TERMINAL RESISTANCE) METRES			
	CONCENTRIC		OPEN FLUE	
	80/125	100/150	80	100
Model				
30/30P	42	-	65	-
40/40P	52	-	70	-
60/60P	7.5	30	25	-
80/80P	12	35	22	-
100	-	14.3	-	20
120	-	17.6	-	49
150	-	7.5	-	32

TABLE 2

Size	EQUIVALENT LENGTH OF ELBOWS (METRES)			
	CONCENTRIC		OPEN FLUE	
	80/125	100/150	80	100
45°	0.85	1.25	0.45	0.60
90°	1.6	1.9	1.0	1.0

EXAMPLES OF FLUE LENGTH CALCULATION

MODEL	FLUE TYPE	MAX PERMISSIBLE EQUIVALENT LENGTH (TABLE 1)	ELBOWS			TOTAL EQUIVALENT LENGTH	MAX PERMISSIBLE STRAIGHT LENGTH
			TYPE	EQUIVALENT LENGTH (TABLE 2)	NO		
60	80/125	7.5	90	1.6	2	3.2	4.3
60	100/150	30	90	1.9	2	3.8	26.2
80	80/125	12	90	1.6	3	4.8	7.2
120	100/150	17.6	90	1.9	4	7.6	10.0

FOR OWN BUILT OPEN FLUE USE THIS:

MAXIMUM ALLOWABLE PRESSURE DIFF & FLUE LENGTH FLUES INCLUDING TERMINAL		
MODEL	FLUE SIZE	PRESSURE DIFF (Pa)
30/30P	80/125	140
40/40P	80/125	225
60/60P	80/125	150
	100/150	150
80/80P	80/125	312
100	100/150	220
120	100/150	365
150	100/150	430

EXAMPLES OF CALCULATING FLUE RESISTANCES/LENGTHS

EXAMPLE 1 (CONCENTRIC)

HORIZONTAL FLUE FOR EVOMAX 40	
	Resistance (m)
Flue size	80/125
Max permissible flue run	42
2 x 90° elbow	2 x 1.6 = 3.2
Total flue length available	42 - 3.2 = 38.8

Therefore this installation is acceptable as only a 2m run.

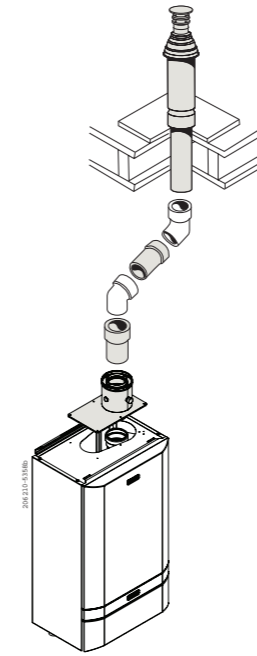
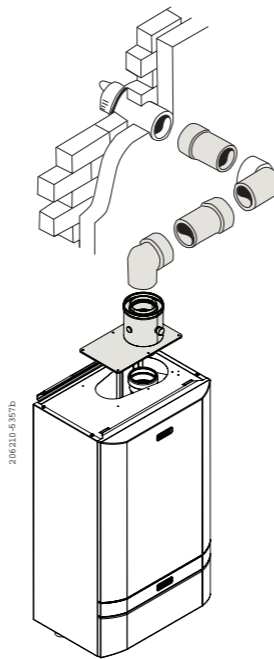

EXAMPLE 2 (CONCENTRIC)

VERTICAL FLUE FOR EVOMAX 80	
	Resistance (m)
Flue Size	80/125
Max permissible flue run	12
2 x 45°	2 x 0.85 = 1.7
Total Flue Resistance	12 - 1.7 = 10.3

Therefore this installation is acceptable as only a 3m run.

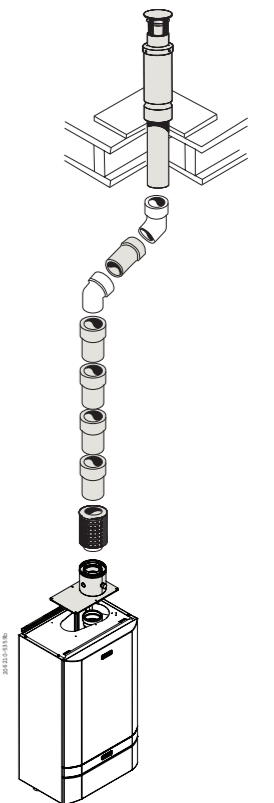

EXAMPLE 3 (OPEN FLUE)

OPEN FLUE FOR EVOMAX 30	
	Resistance (m)
Flue Size	80
Max permissible flue run	65
2 x 45° elbow	2 x 0.45 = 0.9
Total Flue Resistance	65 - 0.9 = 64.1

Therefore this installation is acceptable as only a 6m run.

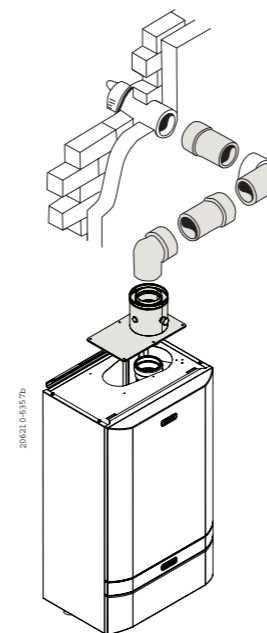

EXAMPLE 4 (CONCENTRIC)

HORIZONTAL FLUE FOR EVOMAX 120	
	Resistance (m)
Flue Size	100/150
Max permissible flue run	17.6
2 x 90° elbow	2 x 1.9 = 3.8
Total Flue Resistance	17.6 - 3.8 = 13.8

Therefore this installation is acceptable as only a 2m run.

MULTILINE CASCADE

*Control setting

The Multiline Flue Cascade is one of the latest additions to the flue accessory range from Ideal, designed specifically for the Evomax range. Available for installations up to 600kW as both a starter kit and extension pack the Multiline system enables Evomax boilers installed as open flue to be connected via a common flue header. This creates a single flue connection point for a flue specialist to design to knowing that the boiler installation is efficient and safe.

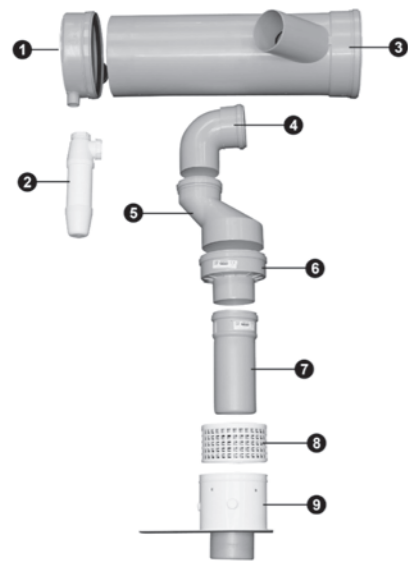

- Simple system ordering with a starter kit and extension kits
- Starter kit includes, appliance connection, non-return flue damper, condensate tee and trap and all clips to secure the flue
- Extension pack includes appliance connection, non-return flue damper, and all clips to secure the flue
- Available for both 80/125 & 100/150 flue adaptor applications
- For installations up to 600kW
- Type B23 flue
- Designed specifically to work efficiently with Evomax appliances with commissioning simply completed by selecting Multiline flue from the installer set up menu
- The perfect addition for Evomax installations using either the standard height or low frame and header kits

PRODUCTS		STARTER KIT	EXTENSION KIT
1	End Cap	☑	
2	Siphon / Condensate trap	☑	
3	Collector Pipe (200 dia)	☑	☑
4	Elbow (90 x 100)	☑	☑
5	Non-Return Valve Connector (100 x 150)	☑	☑
6	Non-Return Valve Body (150 x 100 or 80)	☑	☑
7	Flue Extension Tube (100 or 80)	☑	☑
8	Air Intake Grill	☑	☑
9	Flue Connector (100/150 or 80/125)	☑	☑

The Cascade flue system is supplied in two kits. A Starter Kit & an Extension Kit. Wire retaining clips are also provided to prevent movement of the tube connections due to expansion and contraction. These must be fitted to the ductwork to ensure safe operation of the system.

OPERATION

SYSTEM CONFIGURATIONS

OPTION	GAS TYPE	EVOMAX MODELS	MAX NUMBER OF BOILERS	MAX SYSTEM CAPACITY
1	Natural gas	Combinations of 100, 120, 150	6	600kW
2		Combinations that include a 30, 40, 60 or 80	6	400kW
3	Propane	Combinations of 30P, 40P, 60P, 80P	6	400kW

Flue height = 570mm from the top of the first boiler in the system. Increase the height 29mm for each adjacent boiler.

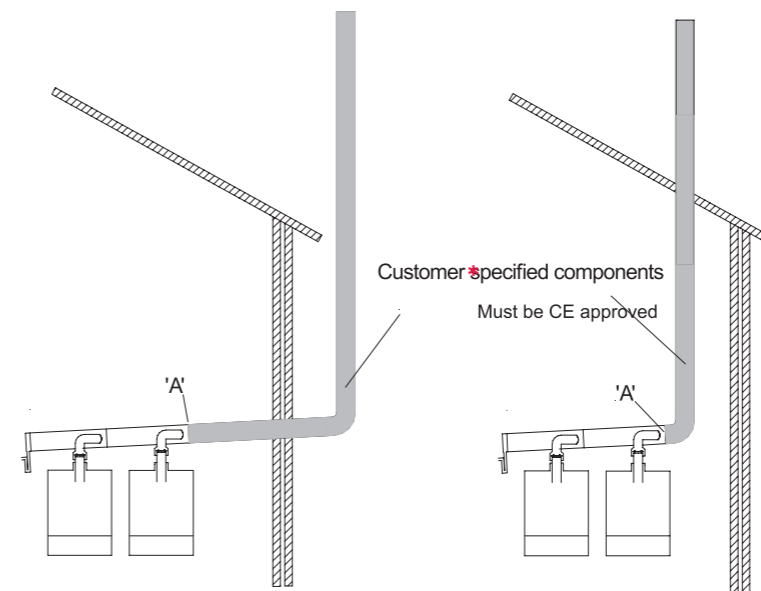
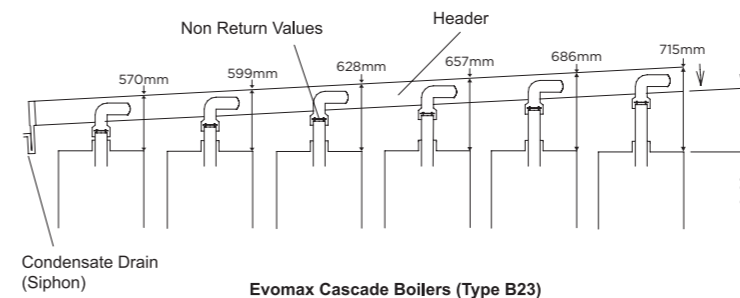

*Multiline flue supplied to point A. Customers are to fabricate / supply B type flue system to termination point within flue resistance parameters.

At the maximum system capacity the static pressure generated against the flue resistance at position [A] must not exceed the value Pmax quoted in the table below.

EVOMAX MODEL OUTPUT		CASCADE SYSTEM LIMITS		COMBUSTION PRODUCTS DATA		
Model		Maximum System Capacity	Maximum Permissible Header Pressure 'A' (Static)	Max rate CO ₂	Min rate CO ₂	Temperature Max
Max	Min	Hmax	Pmax	±0.5	±0.5	
kW	kW	kW	Pa	%	%	C
30	7.5	400	40	9.7	9.0	72
40	10					
60	15					
80	20					
100	25	600	80			
120	30					
150	37.5					
30P	7.5	400	40	11.4	10.6	
40P	10					
60P	15					
80P	20					

EVOMAX PLUME KIT

The Evomax Plume Kit is one of the latest additions to the flue accessory range from Ideal, designed specifically for the Evomax range. Available for Evomax boilers up to 120kW the Plume Kit can be used to relocate the flue terminal up to 10m.

- Suitable for all Evomax up to 120kW
- Available for both 80/125 & 100/150 flue applications
- Plume kit offers terminal relocation up to 10m

- Includes standard appliance connector, horizontal flue kit, special rain collar, external plume kit 1m and terminal
- Offers neat solutions for awkward flue installations where the terminal requires relocation

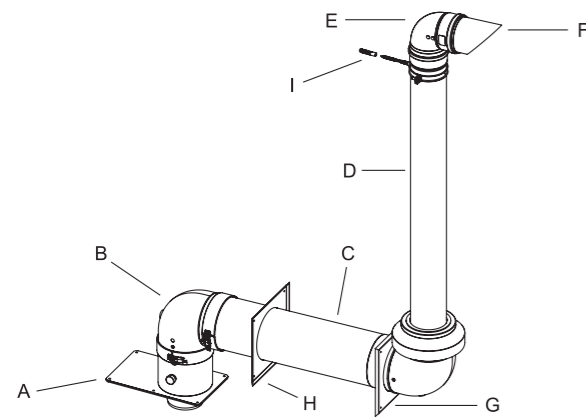

PRODUCTS	
A	Boiler Adaptor
B	Turret elbow
C	Flue terminal with rain cowl & air terminal assembly
D	1 Meter extension tube
E	90 degree elbow
F	Flue terminal end
G	External wall plate
H	Internal wall plate
I	Wall bracket

OPERATION

EVOMAX PLUME KIT - PACKAGED OPTIONS

UIN	DESCRIPTION	DRAWING IDENTIFIER	COMPATIBLE WITH EVOMAX 30, 30P, 40, 40P, 60, 60P, 80, 80P	COMPATIBLE WITH EVOMAX 100, 120
213274	Plume kit 1m extension 80/125	A	☑	
213272	Plume kit 90 deg elbow 80/125	B	☑	
213273	Plume kit 45 deg elbows (pair) 80/125	C	☑	
213277	Plume kit 1m extension 100/150	A	*	☑
213275	Plume kit 90 deg elbow 100/150	B	*	☑
213276	Plume kit 45 deg elbows (pair) 100/150	C	*	☑

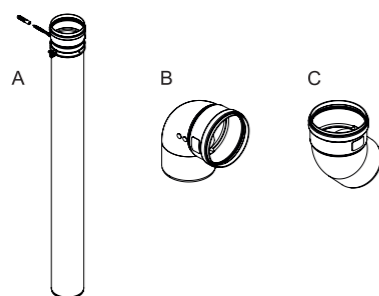

*Note: The 100/150mm Plume Kit system can also be used on Evomax 80, 80P, 60 & 60P model variants if internal concentric wall horizontal flue adaptor is used (Part No. 158660). See main Evomax Literature for details.

EVOMAX PLUME KIT - 80/125

UIN	DESCRIPTION
213270	Plume kit 80/125
213274	Plume kit 1m extension 80/125
213272	Plume kit 90 deg elbow 80/125
213273	Plume Kit 45 deg elbow 80/125 (Pair)

EVOMAX PLUME KIT - 100/150

UIN	DESCRIPTION
213271	Plume kit 100/150
213277	Plume kit 1m extension 100/150
213275	Plume kit 90 deg elbow 100/150
213276	Plume kit 45 deg elbow 100/150 (Pair)

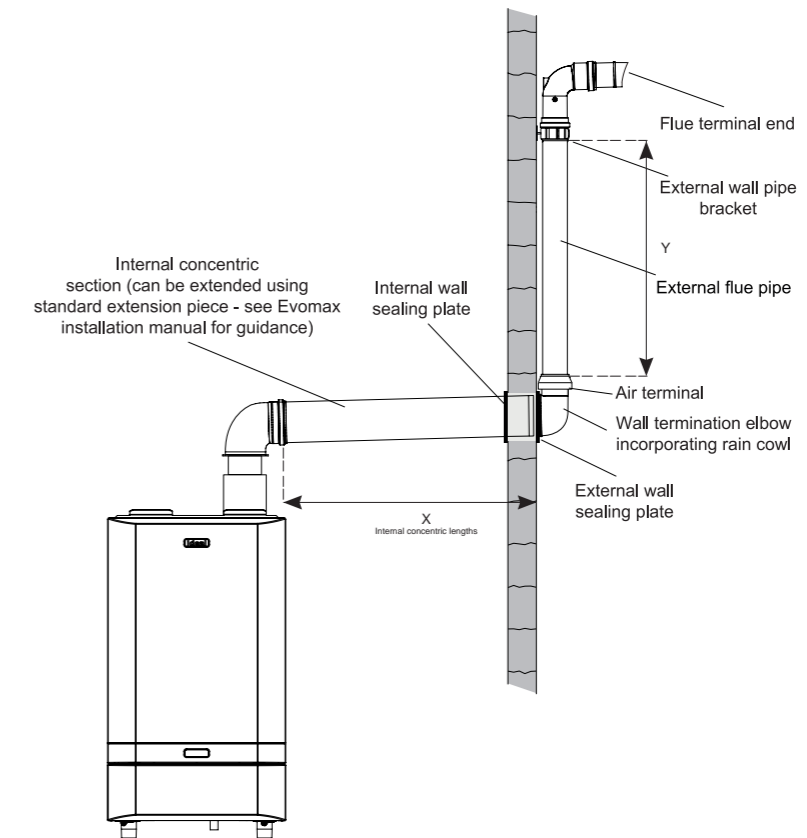

80 / 125 DIA FLUE - MAXIMUM PERMISSIBLE FLUE LENGTHS (M)				
Evomax Model	30/30P	40/40P	60/60P	80/80P
Y	X			
0.5	39.2	39.2	4.7	9.2
2.0	38.5	38.5	4.0	8.5
4.0	37.6	37.6	3.1	7.6
6.0	36.7	36.7	2.2	6.7
8.0	35.8	35.8	1.3	5.8
10.0	34.9	34.9	0.4	4.9

100 / 150 DIA FLUE - MAXIMUM PERMISSIBLE FLUE LENGTHS (M)				
Evomax Model	60/60P	80/80P	100	120
Y	X			
0.5	27.0	32.0	8.0	14.6
2.0	26.6	31.6	7.6	14.2
4.0	26.0	31.0	7.0	13.6
6.0	25.5	30.5	6.5	13.1
8.0	24.9	29.9	5.9	12.5
10.0	24.4	29.4	5.4	12.0

FLUE TYPES

Before ventilation can be sized we need to identify the type of flue system.

Type B - Open flue

Type C - Room sealed

We also need to know the classification of the room type.

- Boiler house - a dedicated building for the installation of boilers and ancillary plant.
- Boiler room - a dedicated room within a building for the installation of boilers and ancillary plant.
- Enclosure - space in which a boiler(s) is installed, which is not large enough to permit access for work other than maintenance via external access.
- Plant room - a room in a building that houses plant and machinery.
- Open space - e.g. in a warehouse.

CLASSIFICATION OF TYPE B FLUES

Appliance type	Primary definition	Natural draught	Fan down stream of heat exchanger	Fan upstream of heat exchanger
B open flue	B1- appliance with a draught diverter	B11	B12 B14*	B13
	B2 - appliance without draught diverter	B21	B22	B23

*Appliance fan also downstream of draught diverter

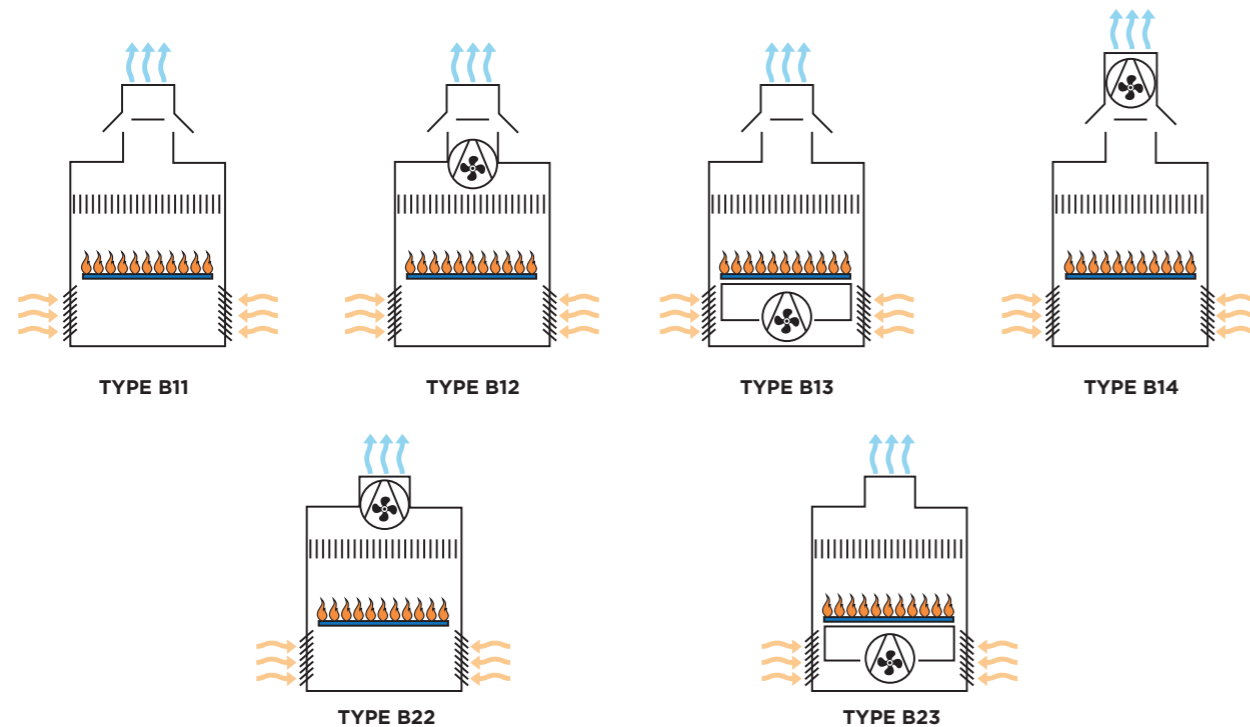

Where 2 or more gas fired boilers are connected to a common natural draught flue, the boilers must be installed in the same room and have the same type of burner system. A gas fired boiler and a solid fuel or biomass boiler must not discharge into the same flue. A gas fired boiler and a liquid fired fuel boiler can discharge into the same flue providing they are both installed in the same room and are force draught.

Appliance type	Primary definition	Natural draught or fan draught		
		Natural draught	Fan down stream of heat exchanger	Fan upstream of heat exchanger
C type Room sealed	C1- appliances with a horizontal balanced flue/ inlet air ducts to outside atmosphere.	C11*	C12	C13*
	C2 - appliance flue connects to a common duct system for multi-appliance installations (the common duct system is part of the building)	C21	C22	C23
	C 3 - appliance with vertical balanced flue/inlet air ducts to outside atmosphere.	C31	C32*	C33*
	C4 - appliance with flue system that connects to a common duct system e.g. 'U' duct flue system.	C41	C42	C43
	C5 - appliance with a non-balanced flue/inlet air duct system.	C51	C52	C53
	C6 - appliance sold without a flue system	C61	C62	C63
	C7 - appliance connected to a vertical flue to outside atmosphere with the air ducts in the loft (vertex)	C71	C72	C73
	C8- appliance with a non-balanced flue system with an air supply from outside atmosphere and flued into a common duct system.	C81	C82	C83

*Appliance fan also downstream of draught diverter

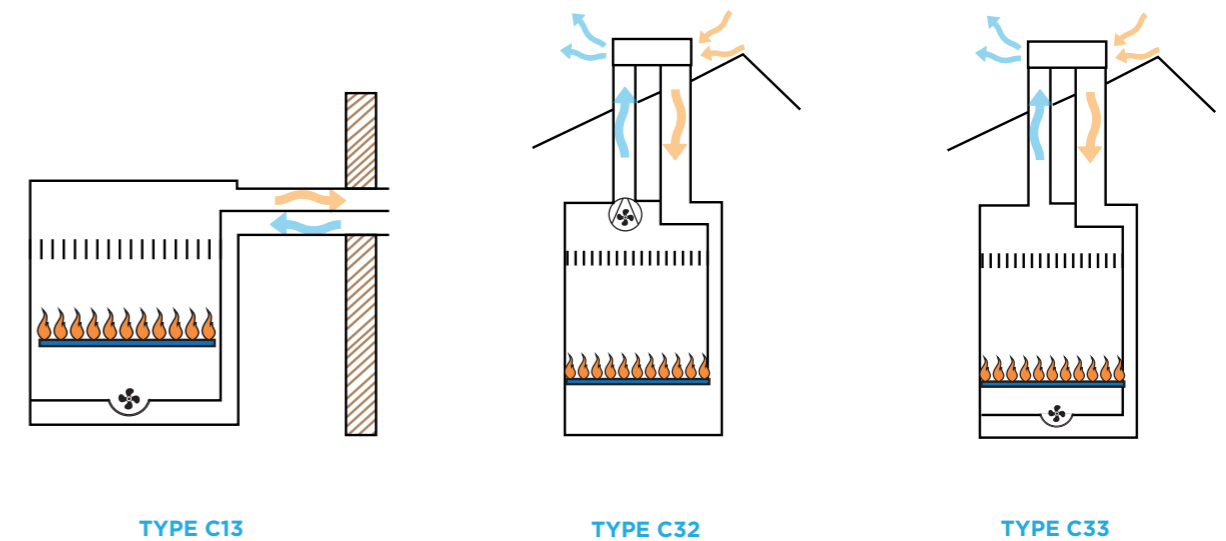

GUIDE TO FLUE INSTALLATION & REGULATIONS

There are many different regulations relating to flues and ventilation. This document will not cover all of them but assist in obtaining information and guidance, and provide useful and practical information.

This guide looks at common standards used to determine the requirements for flue and ventilation installation requirements and should not be used as a sole reference for flue regulations. Please also remember to use the installation and service manual for specific guidance for each boiler and to refer to the relevant standards.

COMMERCIAL BOILERS (70kW - 1.8MW)

BS6644	Specification for the installation and maintenance of gas-fired hot water boilers of rated inputs between 70 kW (net) and 1.8 MW (net) (2nd and 3rd family gases). In IE refer to I.S. 820.
IGEM UP10	Installation of flued gas appliances in industrial and commercial premises.
Building Regs Part J	Combustion appliances and heat storage, gives advice on how to comply with Building Regulations.
Clean Air Act (1956 Amendment)	A UK Parliament Act passed in response to London's Great Smog of 1952.

The Act introduced a number of measures to reduce air pollution, especially by introducing 'smoke control areas' in some towns and cities in which only smokeless fuels could be burned. By shifting homes' sources of heat towards cleaner coals, electricity, and gas, it reduced the amount of smoke pollution and sulphur dioxide from household fires. Reinforcing these changes, the Act also included measures to relocate power stations away from cities, and for the height of some chimneys to be increased.

The Act was an important milestone in the development of a legal framework to protect the environment.

Although smog is no longer an issue, more recent editions of the Clean Air Act have maintained control of emissions and heights of flues.

WHEN SHOULD I USE COMMERCIAL FLUE REQUIREMENT LEGISLATION AND GUIDANCE?

BS5440 covers domestic installations up to 70kW net input, however if an appliance is to be installed in a factory location even if under 70kW then the commercial requirements of IGE UP10 & BS6644 must be adopted.

Similarly if a cascade boiler installation is fitted and the total input exceeds 70kW then the commercial flues and ventilation should be adopted.

WHAT IS GUIDANCE AND WHAT IS MANDATORY?

British Standards are a mandatory requirement. The approved documents offer guidance on how to comply and are not legally binding unless the manufacturer of the appliance stipulates them in the installation manual. It is prudent however to follow them because they would likely be used in a court of law as the minimum expected by a competent person to install a safe system.

Building Regs offer guidance in the same way as British Standards.

IGEM Documents offer guidance in the same way as British standards. However these have been set and adopted by a board of industry experts and represent current best practice and are aligned with National/International legislation and standards.

Clean Air Act - This is a mandatory requirement as set out in Government legislation.

Gas Safety (Installation and Use) Regulations 1998 - These are mandatory and set out the requirements for safe installations.

CLEAN AIR ACT - THE FACTS

The Act applies to gas (and other fuels) fired appliance installations generally but with specific requirements for installations exceeding (333 kW net heat input) including approval of the height of the chimney by the Local Authority. The essential requirements are that flue discharges are not to cause a nuisance to others or be a hazard to health.

In 1956 there was a clean air act memorandum that stated appliances with gross input of 150kW must terminate vertically. This has no foundation in law and was not written for modern high efficiency products. To this effect the current guidance suggests that all installations from 135kW net input that wish to terminate horizontally should be subject to a risk assessment which can be found in IGEM UP10.

All installations are subject to the clean air act requirements:-

Installations below 333kW net heat input can terminate horizontally at low level subject to a risk assessment and complying with all other clearance distances as defined in IGEM UP10.

- Appliance inputs greater than 333kW net need prior approval from the Local Authority with position of flue termination agreed by them.
- No terminal fitted to natural draught flues should be less than 170mm.
- Terminal positions for fanned or natural draught flues shall be clear of obstructions and openings into buildings. Wall terminations shall be directed away from the building.
- Vertical outlets must be the minimum required above the roof level.
- Any horizontal outlet below 2m must be guarded and a minimum of 300mm above ground level.

TERMINATION POSITIONS APPLIANCES OVER 70kW NET INPUT

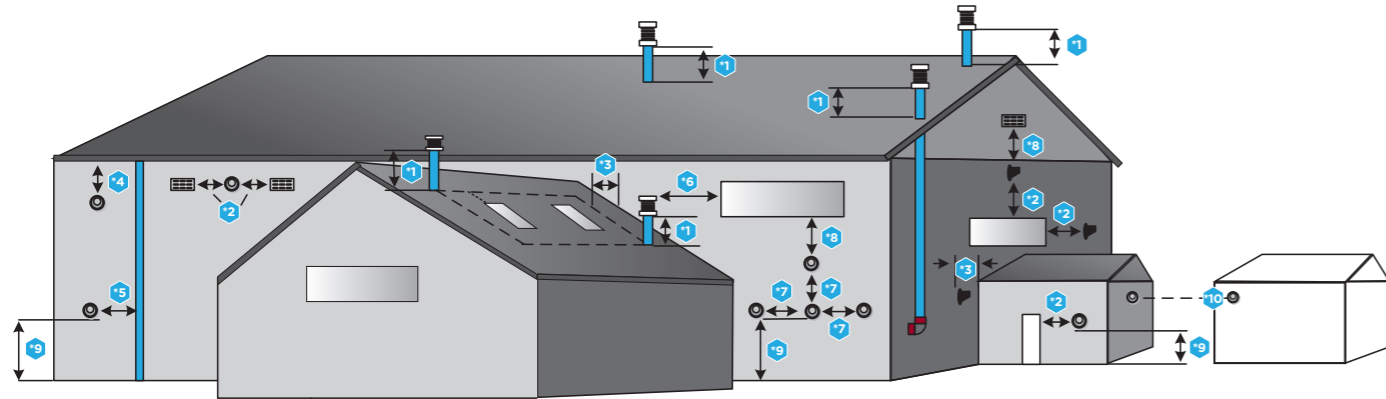

Key to Diagram:

- *1 - Minimum termination height for ridged and flat roofs.
- *2 - Minimum horizontal termination distance from openings i.e. doorways, windows, ventilation grilles, etc.
- *3 - Minimum horizontal termination distance from adjacent walls or obstructions.
- *4 - Minimum distance to be 200 mm for fan assisted appliances, 300 mm for room sealed natural draught appliances, see BS 5440.
- *5 - Minimum distance to be 150 mm, see BS 5440.
- *6 - Minimum termination distance from openings i.e. doorways, windows, ventilation grilles, etc.
- *7 - Minimum distance of centres of flue terminal, see manufacturer's instructions.
- *8 - Minimum distance below terminal or opening 2.5 m.
- *9 - Minimum 300mm above the ground. If less than 2m subject to a risk assesment (fig.1).
- *10 - Opposing a terminal or flat surface.

SEE IGM 10 FOR FURTHER DETAILS

1, 3 & 6 Minimum Height of Termination Located on a roof								
	70kW	80kW	100kW	120kW	150kW	200kW	240kW	300kW
Natural Draught	600mm	615mm	645mm	676mm	722mm	798mm	859mm	950mm
For other natural draught appliances use Distance = 1.5225 (net heat input kW) + 493.43								
Fanned Draught	300mm	327mm	380mm	433mm	513mm	646mm	753mm	913mm
For other fan draught appliances use Distance = 2.6644 (net heat input kW) +113.49								
For all sloped roofs over 20 degree pitch the terminal must be 1.5m away								
If the flue termination is within 2.5m of an adjacent structure then these heights above the structure will apply								

2 Minimum Horizontal Termination To Openings Into Buildings (side or above)								
	70kW	80kW	100kW	120kW	150kW	200kW	240kW	300kW
Open Flue and Fanned Draught	1500mm	1600mm	1790mm	1975mm	2265mm	2740mm	3120mm	3690mm
For other open flue fan draught inputs use Distance = 9.5156 x (net heat input) + 833.91								
Room Sealed Fanned Draught	600mm	675mm	820mm	960mm	1180mm	1540mm	1830mm	2265mm
For other room sealed fan draught inputs use Distance = 7.232 x (net heat input) + 93.708								
The minimum distance below in all cases is 2500mm								

10 Room Sealed Fanned Draught Minimum Horizontal Termination To Opposing Walls/Terminals								
	70kW	80kW	100kW	120kW	150kW	200kW	240kW	300kW
Opposing Flat Surface	1000mm	1231mm	1694mm	2156mm	2850mm	4006mm	4931mm	6319mm
For other inputs use Distance = 23.126 x (net heat input) - 618.84								
Opposing Terminal	600mm	675mm	820mm	960mm	1180mm	1540mm	1830mm	2265mm
For other inputs use Distance = 19.32 x (net heat input) + 647.59								

VENTILATION REQUIREMENTS OF COMMERCIAL BOILERS OVER 70kW NET INPUT

OPEN FLUED APPLIANCES, TYPE B & C IN PLANT ROOMS

FLUE TYPE	VENTILATION DIRECT TO OUTSIDE AIR (cm ² per kW net heat input)	
	HIGH	LOW
OPEN (TYPE B)	2	4
OPEN (TYPE C)	2	2

OPEN FLUED APPLIANCES, TYPE B IN PLANT ROOMS (ADDITIONAL RECOMMENDATIONS)

Natural Ventilation cm ² kw (net) heat input for open flue boilers located in a boiler house				
	(A) Boiler House	(B) Enclosure	Summer usage* greater than 50% up to 75%	Summer usage* greater than 75% up to 100%
High	2	5	+1	+2
Low	4	10	+1	+2

*for boilers in use for more than 50% of the time during the summer months, additional ventilation needs to be added to those in columns A and B

OPEN FLUED APPLIANCES, TYPE C IN PLANT ROOMS (ADDITIONAL RECOMMENDATIONS)

Natural Ventilation cm ² kw (net) heat input for open flue boilers located in a boiler house					
	(A) Boiler House	(B) Enclosure		Summer usage* greater than 50% up to 75%	Summer usage* greater than 75% up to 100%
		To a room or internal space	Direct to outside air		
High	2	10	5	+1	+2
Low	2	10	5	+1	+2

*for boilers in use for more than 50% of the time during the summer months, additional ventilation needs to be added to those in columns A and B

- High level ventilation openings shall be located as high as is reasonably practicable and preferably within 15% of the building height from the ceiling.
- Low level ventilation openings shall be within 1m of the floor for Natural Gas and within 250mm of the floor for LPG.
- For LPG it is preferable that low level ventilation openings are located at floor level.
- Ventilation to an internal space is not generally recommended unless a Risk Assessment has been completed.
- The air supplied for boiler room ventilation shall be such that the maximum temperature within the boiler house is:
 - 25°C at floor level (or 100mm above floor level)
 - 32°C at mid level (1.5 m above floor level)
 - 40°C at ceiling level (or 100mm below ceiling level)

MECHANICAL VENTILATION

- Mechanical ventilation can be a combination of mechanical inlet and outlet or mechanical inlet and natural ventilation outlet.
- The fans shall be selected and controlled so as to not cause a negative pressure (relative to the outside atmosphere) developing in the boiler room.
- Interlocked to the gas appliance.

MINIMUM QUANTITY OF MECHANICAL VENTILATION

Mechanical ventilation m ³ /hr per kW net heat input				
	(A) Min inlet air m ³ /hr	(B) Difference between inlet and extract air [†] m ³ /hr	Summer usage ^{††} greater than 50% up to 75%	Summer usage ^{††} greater than 75% up to 100%
Boiler(s) with draught diverter	2.8	2.07 ±0.18	+0.72	+1.44
Boiler(s) without draught diverter ^{†††}	2.6	1.35 ±0.18	+0.72	+1.44

[†]inlet air minus ventilation 2.8 - 2.07 = 0.73m³/hr
^{††}For boilers in use for more than 50% of the time during the summer months, additional mechanical ventilation needs to be added to those columns A and B
^{†††} with or without draught stabilisers

WATER TREATMENT

IMPORTANT

The application of any other treatment to this product may render the guarantee of Ideal Boilers invalid. Ideal Boilers recommend Water Treatment in accordance with the Benchmark Guidance Notes on Water Treatment in Central Heating Systems. If water treatment is used Ideal Boilers recommend only the use of Scalemaster Gold 100, Fernox, MB-1, Adey MC1, Sentinel-X100, CALMAG CM100 inhibitors and associated water treatment products, which must be used in accordance with the manufacturers' instructions.

NOTES

1. It is most important that the correct concentration of the water treatment products is maintained in accordance with the manufacturers' instructions.
2. If the boiler is installed in an existing system any unsuitable additives MUST be removed by thorough cleansing. BS 7593:2006 details the steps necessary to clean a domestic heating system.
3. In hard water areas, treatment to prevent lime scale may be necessary - however the use of artificially softened water is NOT permitted.
4. Under no circumstances should the boiler be fired before the system has been thoroughly flushed.

FOR FURTHER INFORMATION CONTACT:

Fernox Alent plc
 Forsyth Road, Sheerwater, Woking, Surrey
 GU21 5RZ
 Tel: +44 (0) 870 601 5000

Sentinel Performance Solutions
 7560 Daresbury Park
 Daresbury, Warrington
 Cheshire
 WA4 4BS
 Tel: 0800 389 4670
 www.sentinelprotects.com

Scalemaster Water Treatment Products
 Emerald Way, Stone, Staffordshire
 ST15 0SR
 Tel: 01785 811636

Calmag Ltd.
 Riverview Buildings
 Bradford Road, Riddlesden,
 Keighley, West Yorkshire
 BD20 5JH
 Tel: +44 (0) 1535 210 320

Adey Professional Heating Solutions
 Gloucester Road,
 Cheltenham GL51 8NR
 Tel: +44 (0) 1242 546700

DOMESTIC BOILERS (UP TO 70kW)

BS5440

Flues and ventilation for gas appliances of rated input not exceeding 70 kW net (1st, 2nd and 3rd family gases). Specification for the installation and maintenance of ventilation provision for gas appliances. In I.E refer to I.S. 813.

FLUE TERMINATION POSITION

Due to the high efficiency of these boilers pluming will occur. For this reason vertical termination is recommended, and in any case, terminal positions which could cause problems should where possible be avoided.

Particular care should be taken in the case of large multiple boiler installations, and complying with the requirements of the Clean Air Act. The information below is extracted from BS. 5440 Pt. 1 and is for boilers with heat inputs not exceeding 70kW nett, and the latest Building Regulation Part J. Detailed reference should still be made to these standards. In IE refer to I.S. 813:2002.

CONCENTRIC WALL TERMINAL POSITIONS	MINIMUM SPACING
A. Below an opening (1)	300mm
B. Above an opening (1)	300mm
C. Horizontally to an opening (1)	300mm
D. Below gutters, soil pipes or drain pipes	75mm
E. Below eaves	200mm
F. Below balcony or car port roof	200mm
G. From a vertical drain pipe or soil pipe	150mm
H. From an internal or external corner or to a boundary alongside the terminal	300mm
I. Above ground, roof or balcony level	300mm
J. From a surface or a boundary facing the terminal	600mm
K. From a terminal facing the terminal	1200mm
L. From an opening in the car port into the building	1200mm
M. Vertically from a terminal on the same wall	1500mm
N. Horizontally from a terminal on the same wall	300mm
CONCENTRIC ROOF TERMINAL POSITIONS	
Directly below an opening, air brick, windows, etc.	300mm
Below plastic/painted gutters	500mm*
Below painted surface	500mm*
Below eaves or balcony	500mm
From wall	1000mm
Below Velux window	2000mm
Above or side of Velux window	600mm

* May be reduced to 300mm if a shield fitted.

(1) An opening here means an openable element, such as a openable window, or a fixed opening such as an air vent. However, in addition, the outlet should not be nearer than 150mm (fanned draught) to an opening into the building fabric formed for the purpose of accommodating a built in element, such as a window frame.

If the terminal is fitted less than 500 mm below plastic gutters, painted eaves or any other painted surface then an aluminium shield at least 1m long should be fitted to protect the surface. For positioning of open flue terminals reference should be made to BS. 5440 Pt. 1. In IE refer to I.S. 813:2002

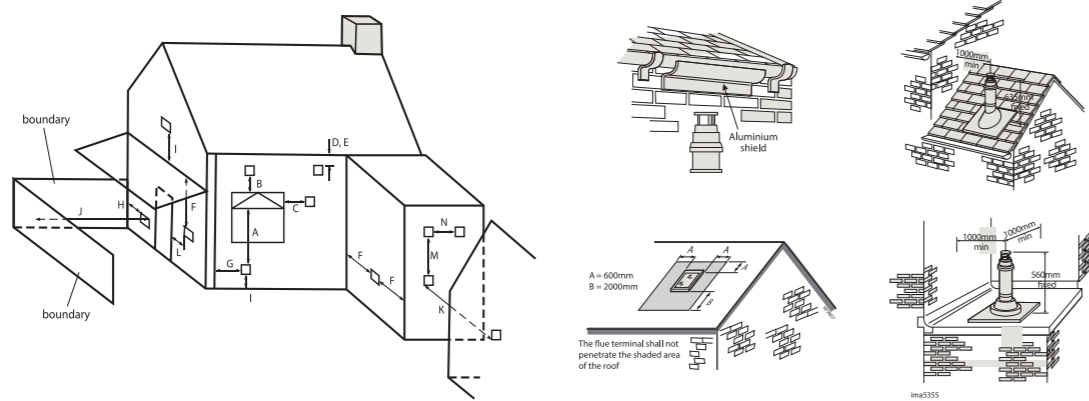

Heat inputs in excess of 70kW nett.
For boiler installations with total heat inputs in excess of 70kW nett, reference should be made to bs6644.
In ie refer to I.S. 820:2000.

VENTILATION

The ventilation requirements of these boilers is dependant on the type of flue system used, and their heat input. All vents must be permanent with no means of closing, and positioned to avoid accidental obstruction by blocking or flooding.

EVOMAX 30/30P, 40/40P, 60/60P

Detail reference should be made to BS. 5440 Pt. 2. In IE refer to the current edition of I.S. 813.

The following notes are for general guidance only: If installed as a room sealed appliance in a room or internal space, then no purpose provided ventilation is required. If installed as an open flued appliance in a room or internal space then a permanent air vent is required. The sizes given below are for vents directly communicating with outside air. For other situations refer to BS. 5440 Pt. 2. In IE refer to the current edition of I.S. 813.

BOILER SIZE	30 & 30P	40 & 40P	60 & 60P
Minimum vent free area (cm ²)	117	167	269

If installed in a compartment, then permanent air vents are required at high and low level. These vents may communicate direct to outside air, or to a room/internal space. If to a room/ internal space, it must itself be adequately ventilated as above.

EVOMAX VENTILATION REQUIREMENTS (NOT EXCEEDING 70KW NET INPUT) WHEN INSTALLED IN A COMPARTMENT

ROOM SEALED APPLICATION - MIN. VENT FREE AREA (CM ²)	TO A ROOM OR INTERNAL SPACE			TO OUTSIDE AIR			OPEN FLUE APPLICATION - MIN. VENT FREE AREA (CM ²)					
	30	40	60	30	40	60	TO A ROOM OR INTERNAL SPACE	TO OUTSIDE AIR				
Boiler Size	30	40	60	30	40	60	30	40	60	30	40	60
High Level	310	410	610	155	205	305	310	410	610	155	205	305
Low level	310	410	610	155	205	305	620	820	1220	310	410	610

The temperature within the boiler room shall not exceed 25°C within 100mm of the floor, 32°C at mid height and 40°C within 100mm of the ceiling.

CONDENSATE PUMPS

The condensate pump is designed to collect and remove condensate and can be used with high efficiency condensing boilers.

TECHNICAL INFORMATION

Maximum flow rate	440 litres/hour
Electrical supply	230V AC / 50-60 Hz 0.8amps
Alarm contact	NC 4 Amps resistive
Overheat protection	130 °C
Tank Capacity	2.0 Litres
Maximum vertical head	4.5m
Maximum horizontal length	30m

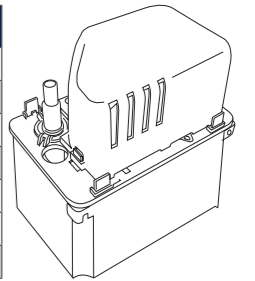

IDEAL COMMERCIAL BOILERS - CONDENSATE PUMP COMPATABILITY

BOILER	COMPATABLE
EVOMAX - 30 - 150kW	✓
IMAX XTRA - 80 - 280kW	✓
IMAX XTRA EL - 320 - 1240kW	✓
EVOMOD - 250 - 1000kW	✓
EVOJET - 150 - 1450kW	✓

TYPICAL CONDENSATE SYSTEMS

SEE GUIDE FOR FULL INSTALLATION INSTRUCTIONS AND SYSTEM OPTIONS

1. INTERNAL TO SINK WASTE UPSTREAM OF SINKWASTE TRAP

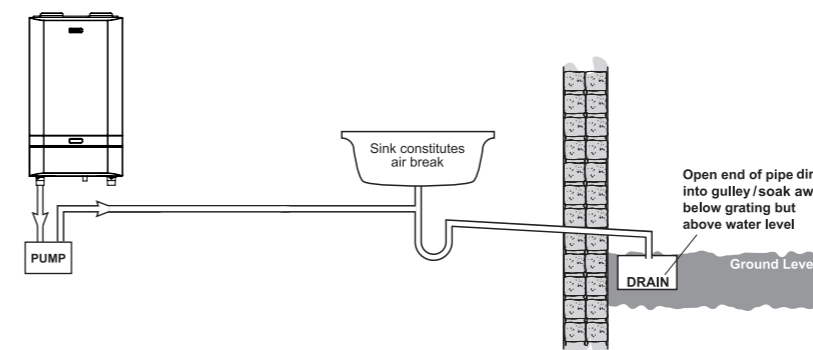

2. TERMINATION TO DRAIN / GULLEY

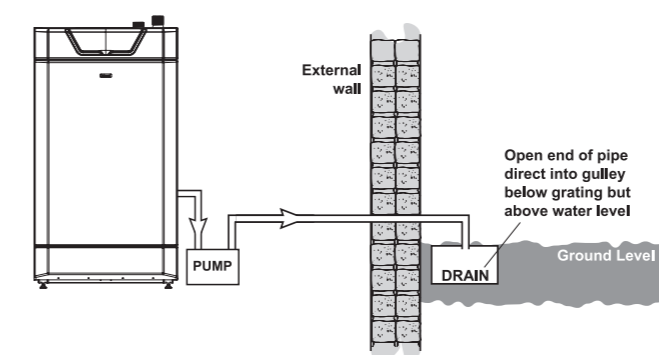



HERE FOR YOU.

At Ideal, we are committed to delivering the highest levels of customer service. With over a century of experience in the heating industry, we know how important confidence and trust is to our customers.

You can be confident to know that you're partnering with a British manufacturer that's supported by a dedicated national service team, delivering help and advice to you and your customers throughout the year.

NEED HELP?

GET IN TOUCH WITH US TODAY

SALES

Tel: 0844 5436060
Fax: 0844 5436181

TECHNICAL

Tel: 01482 498376 Fax: 01482 498621
commercial.services@idealboilers.com

BOILER TRAINING

WE'VE GOT TRAINING COVERED

Our comprehensive one-day courses can be mixed and matched for individual installation and servicing companies. Each course uses a simple step-by-step approach with hands on training to ensure all aspects of commissioning, servicing, and fault finding can be dealt with quickly and efficiently.

BOOK ONLINE AT:

idealcommercialboilers.com



NOTES.



NOTES.



WE HAVE IT **COVERED.**

P.O. Box 103, National Avenue
Kingston Upon Hull, HU5 4JN

T: 0844 5436060

F: 0844 5436181

idealcommercialboilers.com

 @idealboilers  Ideal Boilers



APPROVAL

These appliances are certified to G.A.D. 90/396 and B.E.D. 92/42 Safety and Performance Directives for gas boilers. Ideal Commercial Boilers pursues a policy of continuous improvement in design and performance of its products and reserves the right to vary specification without notice. Statutory rights of the consumer are not affected.

PLEASE NOTE:

The information in this brochure was correct at the time of going to print. Ideal Commercial Boilers reserve the right to make any modifications to product specifications or any other details, without prior notification. For further clarification, please enquire in writing to the head office address (address below).